

---

---

# GPSRXNV-01

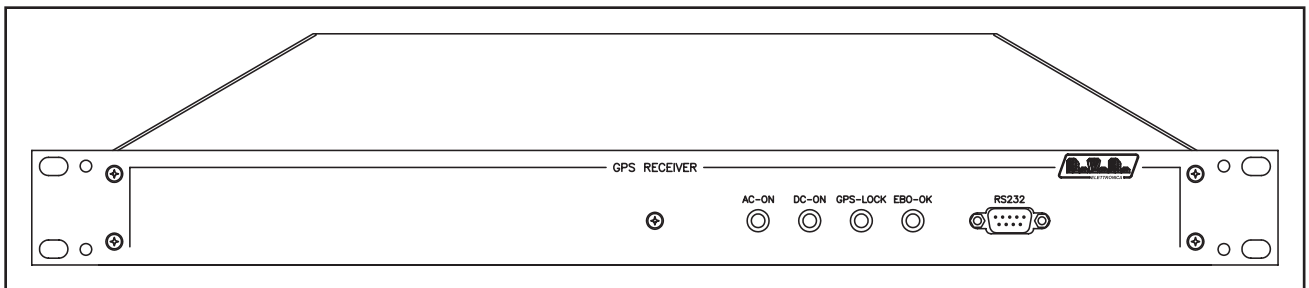

## User Manual Volume 1

---

---

Manufactured by



Italy



**Name File:** 03\_GPSRXNV-01\_ING\_1.0.indd

**Version:** 1.0

**Date:** 16/11/2007

### Revision History

Date	Version	Reason	Editor
16/11/2007	1.0	First Edition	J. H. Berti

GPSRXNV-01 - User Manual  
Version 1.0

© Copyright 2007

R.V.R. Elettronica SpA

Via del Fonditore 2/2c - 40138 - Bologna (Italia)

Telefono: +39 051 6010506

Fax: +39 051 6011104

Email: info@rvr.it

Web: www.rvr.it

All rights reserved

Printed and bound in Italy. No part of this manual may be reproduced, memorized or transmitted in any form or by any means, electronic or mechanic, including photocopying, recording or by any information storage and retrieval system, without written permission of the copyright owner.

#### Declaration of Conformity

Hereby, R.V.R. Elettronica SpA, declares that this FM transmitter is in compliance with the essential requirements and other relevant provisions of Directive 1999/5/EC.



# Table of Contents

<b>1. Preliminary Instructions</b>	<b>1</b>
<b>2. Warranty</b>	<b>1</b>
<b>3. First Aid</b>	<b>2</b>
3.1 Treatment of electrical shocks	2
3.2 Treatment of electrical Burns	2
<b>4. Unpacking</b>	<b>3</b>
4.1 General Description	3
<b>5. Quick guide for installation and use</b>	<b>4</b>
5.1 Preparation	4
<b>6. External Description</b>	<b>8</b>
6.1 Frontal Panel	8
6.2 Rear Panel	8
6.3 Connectors description	9
<b>7. Technical Specifications</b>	<b>10</b>
7.1 Mechanical Specifications	10
7.2 Electrical Specifications	10
7.3 Spare Parts	10
<b>8. Module identification</b>	<b>12</b>
8.1 Top View	12
<b>9. Working Principles</b>	<b>13</b>
9.1 Power supply card (PSS1201-01)	13
9.2 Interface card (SL041IN1001)	13
9.3 Panel board (SL041PC1001)	14

*This page was intentionally left blank*

**IMPORTANT**

The symbol of lightning inside a triangle placed on the product, evidences the operations for which is necessary gave it full attention to avoid risk of electric shocks.



The symbol of exclamation mark inside a triangle placed on the product, informs the user about the presence of instructions inside the manual that accompanies the equipment, important for the efficacy and the maintenance (repairs).

## 1. Preliminary Instructions

### • General foreword

The equipment in object is to considering for uses, installation and maintenance from "trained" or "qualified" staff, they conscious of the risks connected to operate on electronic and electrical circuits electrical.

The "trained" definition means staff with technical knowledge about the use of the equipment and with responsibility regarding the own safety and the other not qualified staff safety place under his directed surveillance in case of works on the equipment.

The "qualified" definition means staff with instruction and experience about the use of the equipment and with responsibility regarding the own safety and the other not qualified staff safety place under his directed surveillance in case of works on the equipment.

 **WARNING:** The machine can be equipped with an ON/OFF switch which could not remove completely voltages inside the machine. It is necessary to have disconnected the feeding cord, or to have switched off the control panel, before to execute technical operations, making sure himself that the safety connection to ground is connected.

The technical interventions that expect the equipment inspection with circuits under voltage must be carry out from trained and qualified staff in presence of a second trained person that it is ready to intervene removing voltage in case of need.

R.V.R. Elettronica SpA doesn't assume responsibility for injury or damage resulting from improper procedures or practices by untrained/unqualified personnel in the handling of this unit.

 **WARNING:** The equipment is not water resistant and an infiltration could seriously compromise its correct operation. In order to prevent fires or electric shocks, do not expose the equipment to rain, infiltrations or humidity.

Please observe all local codes and fire protection standards during installation and use of this unit.

 **WARNING:** The equipment has to its inside exposed parts to risk of electric shock, always disconnect power before opening covers or removing any part of this unit.

Fissures and holes are supplied for the ventilation in order to assure a reliable efficacy of the product that for protect itself from excessive heating, these fissures do not have to be obstructed or to be covered. The fissures doesn't be obstructed in no case. The product must not be incorporated in a rack, unless it is supplied with a suitable ventilation or that the manufacturer's instructions are been followed.

 **WARNING:** This equipment can irradiate radio frequency energy and if it's not installed following the instructions contained in the manual and local regulations it could generate interferences in radio communications.

 **WARNING:** This device has a connection to ground on the power cord and on the chassis. Check that they are correctly connected.

Operate with this device in a residential ambient can cause radio disturbs; in this case, it can be demanded to the user to take adequate measures.

Specifications and informations contained in this manual are furnished for information only, and are subject to change at any time without notice, and should not be construed as a commitment by R.V.R. Elettronica SpA.

The R.V.R. Elettronica SpA assumes no responsibility or liability for any errors or inaccuracies that may appear in this manual, including the products and software described in it; and it reserves the right to modify the design and/or the technical specifications of the product and this manual without notice.

• **Warning regarding the use designated and the use limitations of the product.**

This product is an transmitter radio indicated for the audio broadcasting service in frequency modulation. It uses working frequencies that are not harmonized in the states of designated user.

The user of this product must obtain from the Authority for spectrum management in the state of designated user the appropriate authorization to use the radio spectrum, before putting in exercise this equipment.

The working frequency, the transmitter power, let alone other specifications of the transmission system are subject to limitation and defined in the authorization obtained.

## 2. Warranty

R.V.R. Electronics S.P.A. guarantees absence of manufacturing defect and the good operation for the products, within the provided terms and conditions.

Please read the terms carefully, because the purchase of the product or acceptance of order confirmation, constitutes acceptance of the terms and conditions.

For the last legal terms and conditions, please visit our web site ([WWW.RVR.IT](http://WWW.RVR.IT)) wich may also be changed, removed or updated for any reason without prior notice.

Warranty will be void in cases of opened products, physical damage, misuse, modification, repair by unauthorised persons, carelessness and using the product for other purpose than its intended use.

In case of defect, proceed like described in the following:

- 1 Contact the dealer or distributor where you purchased the unit. Describe the problem and, so that a possible easy solution can be detected.

Dealers and Distributors are supplied with all the information about problems that may occur and usually they can repair the unit quicker than what the manufacturer could do. Very often installing errors are discovered by dealers.

- 2 If your dealer cannot help you, contact R.V.R. Elettronica and explain the problem. If it is decided to return the unit to the factory, R.V.R. Elettronica will mail you a regular authorization with all the necessary instructions to send back the goods;

- 3 When you receive the authorization, you can return the unit. Pack it carefully for the shipment, preferably using the original packing and seal the package perfectly. The customer always assumes the risks of loss (i.e.,

R.V.R. is never responsible for damage or loss, until the package reaches R.V.R. premises. For this reason, we suggest you to insure the goods for the whole value. Shipment must be effected C.I.F. (PREPAID) to the address specified by R.V.R.'s service manager on the authorization



**DO NOT RETURN UNITS WITHOUT OUR AUTHORIZATION AS THEY WILL BE REFUSED**

- 4 Be sure to enclose a written technical report where mention all the problems found and a copy of your original invoice establishing the starting date of the warranty.

Replacement and warranty parts may be ordered from the following address. Be sure to include the equipment model and serial number as well as part description and part number.



R.V.R. Elettronica SpA  
Via del Fonditore, 2/2c  
40138 BOLOGNA ITALY  
Tel. +39 051 6010506

## 3. First Aid

The personnel employed in the installation, use and maintenance of the device, shall be familiar with theory and practice of first aid.

### 3.1 Treatment of electrical shocks

#### 3.1.1 If the victim is not responsive

Follow the A-B-C's of basic life support.

- Place victim flat on his back on a hard surface.
- Open airway: lift up neck, push forehead back (**Figure 1**).

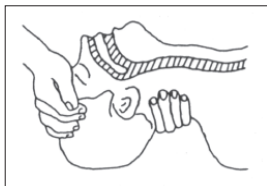

Figure 1

- clear out mouth if necessary and observe for breathing
- if not breathing, begin artificial breathing (**Figure 2**): tilt head, pinch nostrils, make airtight seal, four quick full breaths. Remember mouth to mouth resuscitation must be commenced as soon as possible.



Figure 2

- Check carotid pulse (**Figure 3**); if pulse is absent, begin artificial circulation (**Figure 4**) depressing sternum (**Figure 5**).

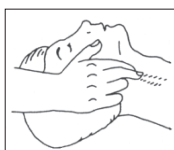

Figure 3



Figure 4

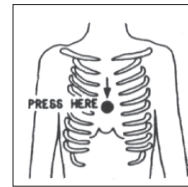

Figure 5

- In case of only one rescuer, 15 compressions alternated to two breaths.
- If there are two rescuers, the rhythm shall be of one breath each 5 compressions.
- Do not interrupt the rhythm of compressions when the second person is giving breath.
- Call for medical assistance as soon as possible.

#### 3.1.2 If victim is responsive

- Keep them warm.
- Keep them as quiet as possible.
- Loosen their clothing (a reclining position is recommended).
- Call for medical help as soon as possible.

### 3.2 Treatment of electrical Burns

#### 3.2.1 Extensive burned and broken skin

- Cover area with clean sheet or cloth.
- Do not break blisters, remove tissue, remove adhered particles of clothing, or apply any salve or ointment.
- Treat victim for shock as required.
- Arrange transportation to a hospital as quickly as possible.
- If arms or legs are affected keep them elevated.

If medical help will not be available within an hour and the victim is conscious and not vomiting, give him a weak solution of salt and soda: 1 level teaspoonful of salt and 1/2 level teaspoonful of baking soda to each quart of water (neither hot or cold).

Allow victim to sip slowly about 4 ounces (half a glass) over a period of 15 minutes.

Discontinue fluid if vomiting occurs.

DO NOT give alcohol.

#### 3.2.2 Less severe burns

- Apply cool (not ice cold) compresses using the cleansed available cloth article.
- Do not break blisters, remove tissue, remove adhered particles of clothing, or apply salve or ointment.
- Apply clean dry dressing if necessary.
- Treat victim for shock as required.
- Arrange transportation to a hospital as quickly as possible.
- If arms or legs are affected keep them elevated.

## 4. Unpacking

The package contains:

- Nr.1 **GPSRXNV-01**
- Nr.1 User Manual
- Nr.1 Mains Power Cord

The following accessories are also available from Your R.V.R. Dealer::

- **Accessories, spare parts and cables**

### 4.1 General Description

The **GPSRXNV-01**, produced by **R.V.R. Elettronica SpA**, is a **GPS receiver (Global Positioning System - alias the satellite navigation system developed and maintained by the U.S. Department of Defense)**, with characteristics that can be used in synchronization systems for isofrequency broadcasting systems (SFN - alias Single Frequency network).

The **GPSRXNV-01** is designed to being contained into a 19" rack box of 1HE.

Two major features of **GPSRXNV-01** is compact design and user-friendliness. Another key feature is its modular-concept design: the different functions are performed by modules with most connections achieved through male and female connectors or through flat cables terminated by connectors. This design facilitates maintenance and module replacement.

The **GPSRXNV-01** contains a buffer battery, to avoid possible lack of power supply, and its internal battery charger.

Four LEDs on the front panel provide the following status indications: AC-ON, DC-ON, EBO-OK and GPS-LOCK.

The rear panel features the VDE mains input connector with voltage selector that allows to use it with different supply voltages, as well as the ON/OFF switch of the buffer battery, the N-type connector for GPS antenna input, the BNC connector for 1PPS output signal, the BNC connector for 10MHz sync signal and the DB9 connector for status alarm signaling.

## 5. Quick guide for installation and use

This section provides a step-by-step description of equipment installation and configuration procedure. Follow these procedures closely upon first power-on and each time any change is made to general configuration, such as when a new transmission station is added or the equipment is replaced.

Once the desired configuration has been set up, no more settings are required for normal operation; at each power-up (even after an accidental shutdown), the equipment defaults to the parameters set during the initial configuration procedure.

The topics covered in this section are discussed at greater length in the next

sections, with detailed descriptions of all hardware and firmware features and

capabilities. Please see the relevant sections for additional details. The topics covered in this section are discussed at greater length in the next sections, with detailed descriptions of all hardware and firmware features and capabilities. Please see the relevant sections for additional details.

### 5.1 Preparation

#### 5.1.1 Preliminary checks

Unpack the GPS receiver and immediately inspect it for transport damage. Ensure that all connectors are in perfect condition.

Provide for the following (applicable to operating tests and putting into service):

- √ Single-phase 230 or 115 (-15% / +10%) Vac mains power supply, with adequate earth connection.
- √ Connection cable kit including:
  - Mains power cable.
  - Cable to connect the 1 PPS TTL signal (**sold separately**).
  - Cable to connect the 10 MHz signal (**sold separately**).
  - GPS receiver antenna (**sold separately**).



## 5.1.2 Preparation of the mains supply



**WARNING:** perform all the operations described in this section with the mains supply disconnected.

The general fuse is accessible from the outside on the rear panel (see figure 6.2). To check the integrity, or for substitution, remove the fuse holder with a screwdriver. The fuse to be used is of type:

**Mains Fuse: 1 A 5x20**



**Note:** the switch (with lock position), for the connection of buffer battery, is kept open (BATTERY OFF position) during transport. ). Check this condition and set the switch to ON BATTERY position (see figure 6.2 - note [11]), after powering the system.

## 5.1.3 Connections

Connect the GPS ANTENNA input of **GPSRXNV-01** (see figure 6.2 - note [11]) to antenna receiver (figure 5.1).

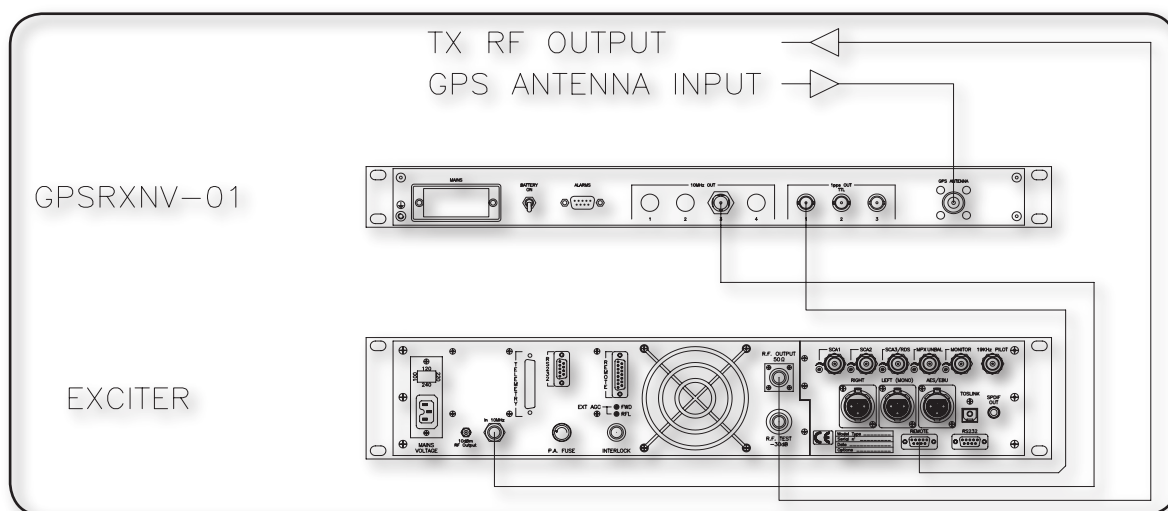

Figure 5.1

Connect the 10MHz OUT - 1 output of **GPSRXNV-01** (figure 6.1 - note [4]) to the proper IN 10MHZ input equipped with apparatus of R.V.R. Elettronica like **PTX-LCD with SFN option** (figure 5.1). If the equipment is of a different brand, identify an equivalent input.

Connect the 1PPS OUT TTL - 1 output of **GPSRXNV-01** (figure 6.1 - note [8]) to the proper REMOTE input equipped with apparatus of R.V.R. Elettronica like **PTX-LCD with SFN option** (figure 5.1). If the equipment is of a different brand, identify an equivalent input.



**Note :** in the following figure is shown the diagram of cable when connecting equipment of R.V.R. Elettronica like the PTX-LCD with SFN option (Figure 5.2).

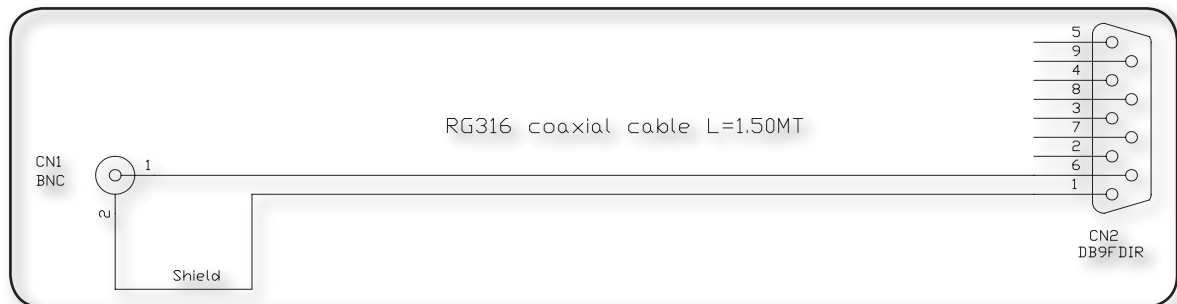

Figure 5.2

Connect the power cable in the proper MAINS connector placed on the rear panel (figure 6.2 - note [1]).



**Note:** The mains must be equipped with adequate ground connection properly connected to the machine. This is a pre-requisite for ensuring operator safety and correct operation.

After connecting the power supply, the receiver performs a bootstrap test lighting on, in sequence, before GPS-LOCK led and then EBO-OK led, soon after light them off. Once that 4 satellites are correctly receipt and decodified, the GPS-LOCK led light on again; when the phase locking of 10MHz e 1PPS signal happens, the EBO-OK will be again light on too.

In case that you made explicit request for purchase the software license of EPSILON BOARD OEM II card at time of order, the reading parameters of **GPSRXNV-01** and of satellites will be made through the serial connection between the RS232 and the DB9 placed in front panel and a compatible PC with Microsoft Windows 98, 2000, XP on which you have installed the software furnished.

The ALARMS DB9 connector (figure 6.2 - note [3]), from which the signals related to the GPS-LOCK and EBO-OK front LEDs come issued, can be used in SFN systems that require a power lowering in case of failure in GPS synchronism.

In case **/DST10** option is present (it gives further 3 auxiliary 10MHz outputs and 2 auxiliary 1pps outputs beyond those already available) connect the remaining outputs depending on your system configuration.

A connection example is shown here below:



Figura 5.3

## 6 External Description

This section describes the components found on the front and rear panel of GPSRXNV-01.

### 6.1 Frontal Panel

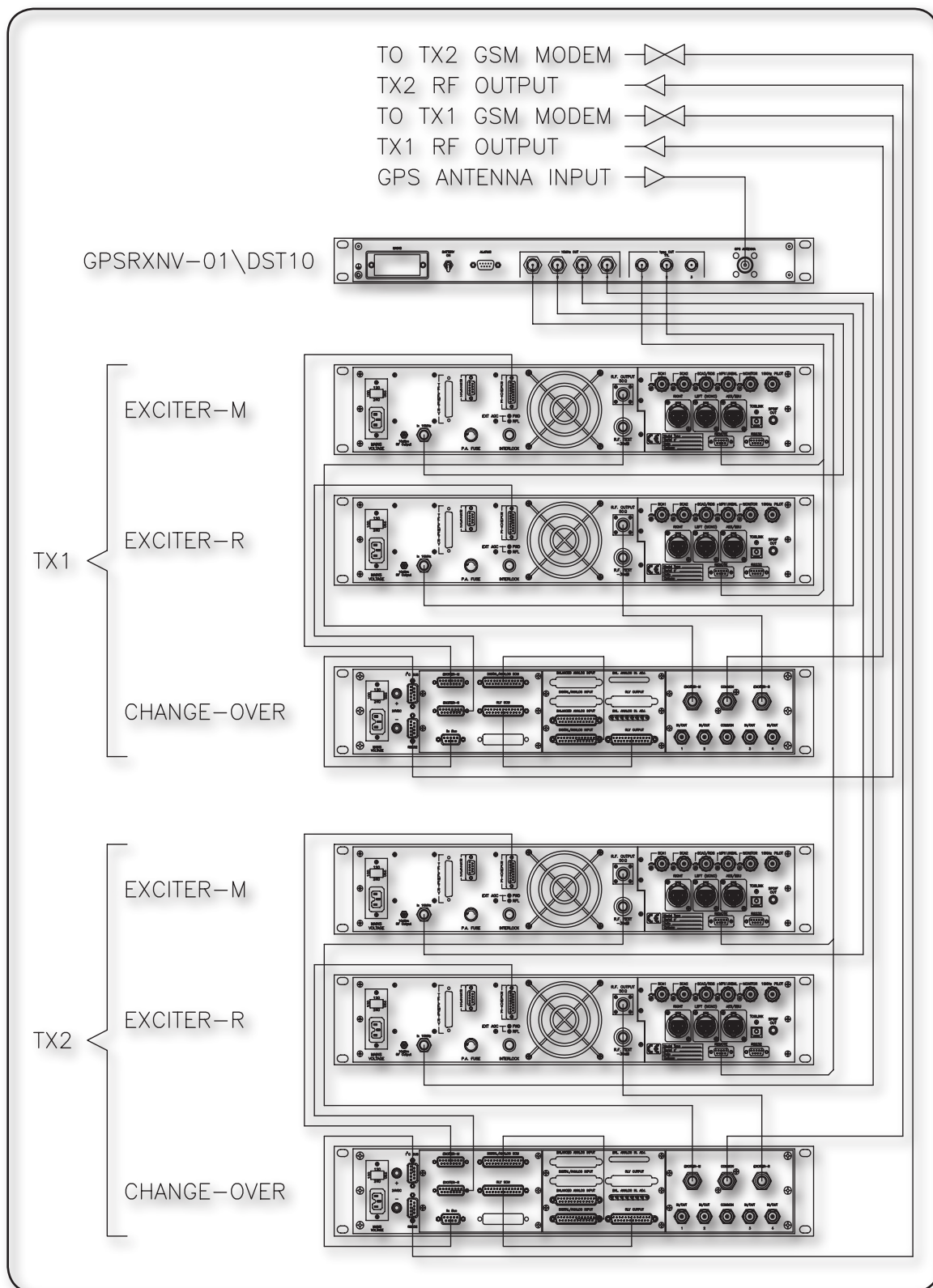
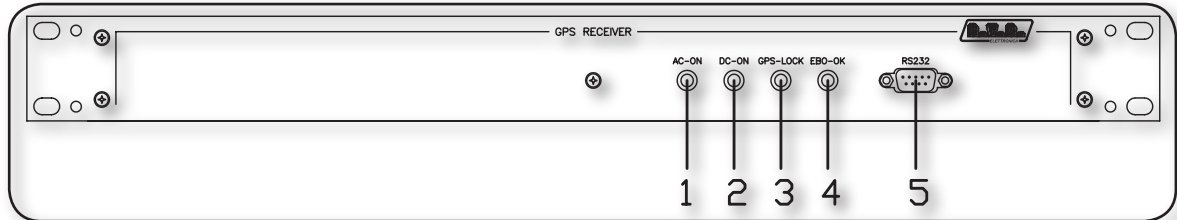

Figure 6.1

- |                                                                                       |                                                                                                                                                                                                                                                                                                                                                                                                                                                                                     |
|---------------------------------------------------------------------------------------|-------------------------------------------------------------------------------------------------------------------------------------------------------------------------------------------------------------------------------------------------------------------------------------------------------------------------------------------------------------------------------------------------------------------------------------------------------------------------------------|
| <p>[1] AC-ON<br/>[2] DC-ON</p> <p>[3] GPS-LOCK</p> <p>[4] EBO-OK</p> <p>[5] RS232</p> | <p>Green LED, when lit on indicates the presence of mains power supply.</p> <p>Green LED, when lit on indicates the presence of continuous power supply; in case this LED is ON while that AC-ON is off, it indicates that the receiver is powered by battery.</p> <p>Green LED, when lit on indicates the correct reception of satellite signals.</p> <p>Green LED, when lit on indicates the correct synchronization.</p> <p>DB9-F connector for direct serial communication.</p> |
|---------------------------------------------------------------------------------------|-------------------------------------------------------------------------------------------------------------------------------------------------------------------------------------------------------------------------------------------------------------------------------------------------------------------------------------------------------------------------------------------------------------------------------------------------------------------------------------|

### 6.2 Rear Panel

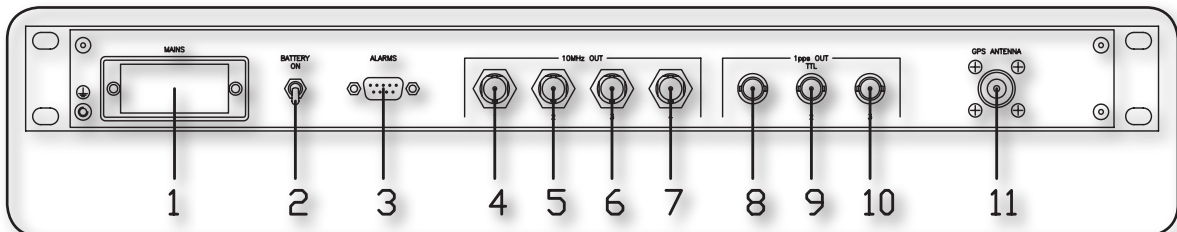

Figure 6.2

- |                                                                                                                                                                                                                                                                    |                                                                                                                                                                                                                                                                                                                                                                                                                                                                                                                                                                                                                                                                                                                                                                                                                                                                                                                                                                                                                                                                                                                                                                                                                                                           |
|--------------------------------------------------------------------------------------------------------------------------------------------------------------------------------------------------------------------------------------------------------------------|-----------------------------------------------------------------------------------------------------------------------------------------------------------------------------------------------------------------------------------------------------------------------------------------------------------------------------------------------------------------------------------------------------------------------------------------------------------------------------------------------------------------------------------------------------------------------------------------------------------------------------------------------------------------------------------------------------------------------------------------------------------------------------------------------------------------------------------------------------------------------------------------------------------------------------------------------------------------------------------------------------------------------------------------------------------------------------------------------------------------------------------------------------------------------------------------------------------------------------------------------------------|
| <p>[1] MAINS</p> <p>[2] BATTERY</p> <p>[3] ALARMS</p> <p>[4] 10MHz OUT - 1</p> <p>[5] 10MHz OUT - 2</p> <p>[6] 10MHz OUT - 3</p> <p>[7] 10MHz OUT - 4</p> <p>[8] 1pps OUT TTL - 1</p> <p>[9] 1pps OUT TTL - 2</p> <p>[10] 1pps OUT TTL - 3</p> <p>[11] GSM ANT</p> | <p>VDE connector for mains power supply, fuse protection and voltage changer block 100-110-230-250V 50-60Hz.</p> <p>Switch to enable or disable the power supply of buffer battery.</p> <p>DB9-M connector for the alarm output status of the equipment through the contacts available.</p> <p>BNC connector for the signal output at 10MHz for the synchronism of the carrier.</p> <p>BNC connector for the auxiliary signal output at 10MHz for the synchronism of the carrier, only in case of presence of proper option.</p> <p>BNC connector for the auxiliary signal output at 10MHz for the synchronism of the carrier, only in case of presence of proper option.</p> <p>BNC connector for the auxiliary signal output at 10MHz for the synchronism of the carrier, only in case of presence of proper option.</p> <p>BNC connector for the signal output of 1 PPS TTL for the synchronism of the carrier.</p> <p>BNC connector for the signal output of 1 PPS TTL for the synchronism of the carrier, only in case of presence of proper option..</p> <p>BNC connector for the signal output of 1 PPS TTL for the synchronism of the carrier, only in case of presence of proper option.</p> <p>Type-N connector for antenna receiver input.</p> |
|--------------------------------------------------------------------------------------------------------------------------------------------------------------------------------------------------------------------------------------------------------------------|-----------------------------------------------------------------------------------------------------------------------------------------------------------------------------------------------------------------------------------------------------------------------------------------------------------------------------------------------------------------------------------------------------------------------------------------------------------------------------------------------------------------------------------------------------------------------------------------------------------------------------------------------------------------------------------------------------------------------------------------------------------------------------------------------------------------------------------------------------------------------------------------------------------------------------------------------------------------------------------------------------------------------------------------------------------------------------------------------------------------------------------------------------------------------------------------------------------------------------------------------------------|

## 6.3 Connectors description

### 6.3.1 RS232

Type: DB9 female

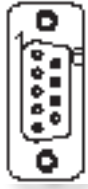

1	NC
2	TX_D
3	RX_D
4	NC
5	GND
6	NC
7	NC
8	NC
9	NC

### 6.3.1 ALARMS

Type: DB9 male

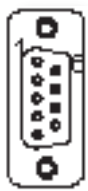

Pin	Name	Type	Purpose
1	GPS-LOCK	OUT dig.	Closed contact if PIN2 is in normal operating condition.
2	GPS-LOCK	OUT dig.	Common contact.
3	GPS-LOCK	OUT dig.	Closed contact if PIN2 is in alarm condition.
4	GPS-LOCK	OUT an.	Tip. JP6 (SL041IN1001) is in pos.2-3 or 3-4: +12V signalling in case of normal operation condition. If JP6 (SL041IN1001) is in pos. 1-2: +12V signalling in case of alarm. If JP6 (SL041IN1001) is in pos. 4-5: +12V always active.
5	GND		GND
6	EBO-OK	OUT dig.	Closed contact if PIN7 is in normal operating condition.
7	EBO-OK	OUT dig.	Common contact.
8	EBO-OK	OUT dig.	Closed contact if PIN7 is in alarm condition.
9	EBO-OK	OUT an.	Tip. JP5 (SL041IN1001) is in pos.2-3 or 3-4: +12V signalling in case of normal operation condition. If JP5 (SL041IN1001) is in pos. 1-2: +12V signalling in case of alarm. If JP5 (SL041IN1001) is in pos. 4-5: +12V always active.

## 7. Technical Specifications

### 7.1 Mechanical Specifications

Size Panel	483 mm (19.02") x 44 mm (1.73") (1 HE)
Depth	407 mm (16.02")
Weight	4 Kg
Operating Temperature	0 °C ÷ +50 °C
Storage Temperature	- 40 °C ÷ + 85 °C 0 °C ÷ +50 °C
Operating Temperature	0 °C ÷ 85 °C, without condensation

### 7.2 Electrical Specifications

#### General

C.A. power supply	100-120-230-250 V <sub>AC</sub> 50-60 Hz
C.C. power supply	+12V <sub>DC</sub>
Accuracy to UTC, with GPS locked	± 50 ns (1σ)
10MHz output frequency accuracy	< ± 2 x 10 <sup>-12</sup>
GPS system	Integrated

#### Antenna Input

Connector	N-type
	Uscita 5V output for antenna power supply

#### 1pps TTL output

Connector	BNC
Typical level	TTL

#### 10MHz output

Connector	BNC
Signal Form	sinusoidal
Typical level	5 dBm / 50Ω
Harmonic Distortion	-25 dBc

#### Connectors

RS232 serial interface	DB9 female connector to connect the receiver to an external devices for programming
ALARMS interface	DB9 male connector signaling of alarm status

#### Options

/DST10	Adds (3x) auxiliary outputs at 10MHz and (2x) auxiliary outputs at 1pps
--------	-------------------------------------------------------------------------

### 7.3 Spare Parts

#### Subsets for Maintenance

Panel board	SL041PC1001
Interface card and battery charger	SL041IN1001
Power supply card	PSS1201-01

#### Parts of parts

Transformer	TRFALT0001
GPS receiver	EPSILON BOARD OEM II
Buffery battery 12V 2Ah	BATTPG12V2A2



## 8. Module identification

Il **GPSRXNV-01** is made up of several modules connected through connectors to facilitate maintenance and replacement (if needed).

### 8.1 Top View

The figure 8.1 shows a top view of the equipment and component locations.

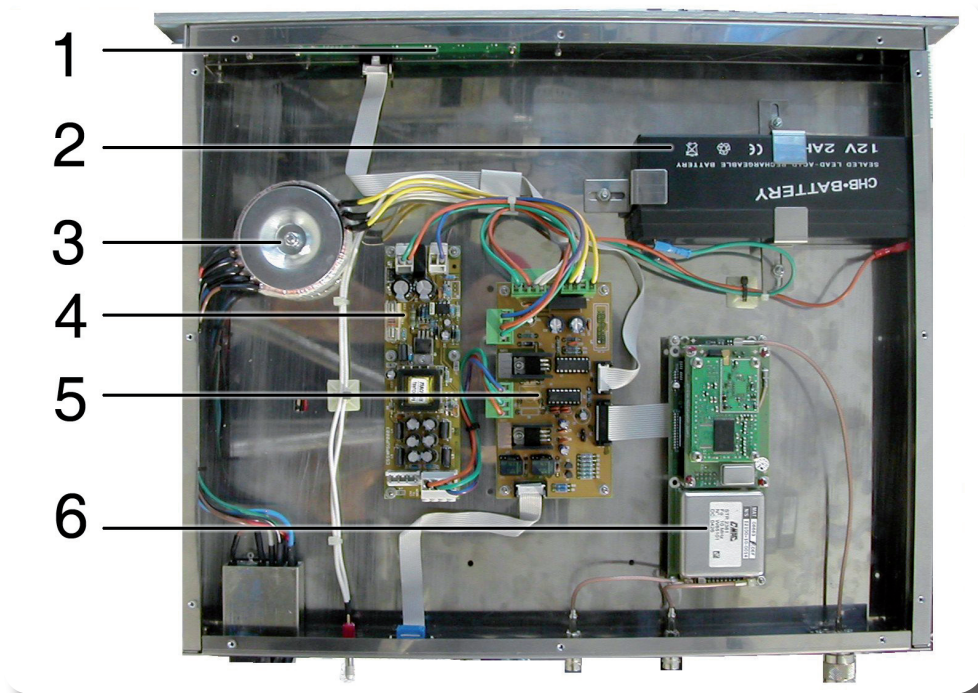

Figure 8.1

- [1] Panel Board (**SL041PC1001**)
- [2] Buffer battery (**BATTPG12V2A2**)
- [3] Transformer (**TRFALT0001**)
- [4] Power supply card (**PSS1201-01**)
- [5] Interface card (**SL041IN1001**)
- [6] GPS receiver (**EPSILON BOARD OEM II**)



## 9. Working Principles

The figures below provide an overview of **GPSRXNV-01** modules and connections.

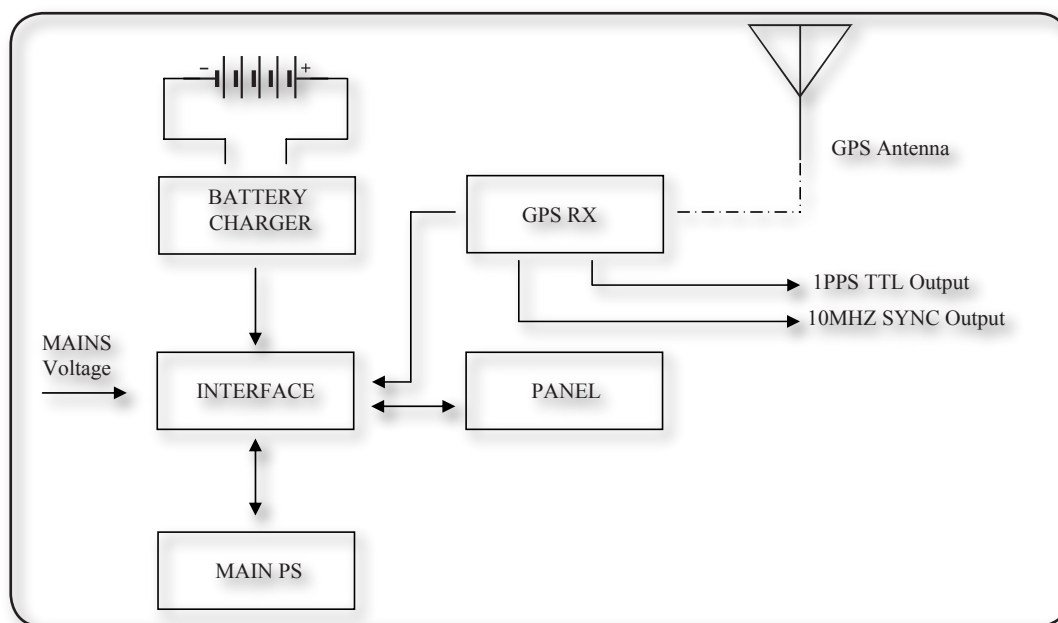

Figure 9.1

Following is a brief description of the different module functions; all diagrams and board layout diagrams are included in the “Technical Schedule” Vol.2.

### 9.1 Power supply card (PSS1201-01)

The power supply section is composed by a transformer which supplies a voltage of +12 V for the power supply of analog section and a voltage of +7 V for the power supply of digital logic section.

In case of absence of network, and in case the switch on the rear panel of the battery is enabled, the equipment automatically switches the power supply on the internal buffer battery thus guaranteeing the continuity of the service.

### 9.2 Interface card (SL041IN1001)

This card performs the following tasks:

- Interfacing and control of receiver module (EPSILON BOARD);
- Interfacing and control of power supply module (SWPSUP0003);
- Supply and control of LED signalling card;
- Control of status and alarm indication of equipment made available on the DB9-M connector.

## 9.3 Panel board (SL041PC1001)

This card is mounted on the frontal panel. The panel board provides the visualization, via LEDs, related to status of equipment.

Also hosts the RS232 connector for direct serial communication (normally used only for factory settings).