



TEX52TFT

TECHNICAL ANNEX VOLUME2



R.V.R. Elettronica
Via del Fonditore, 2 / 2c
Zona Industriale Roveri · 40138 Bologna · Italy
Phone: +39 051 6010506 · Fax: +39 051 6011104
e-mail: info@rvr.it · web: http://www.rvr.it

Member of CISQ Federation



CERTIFIED MANAGEMENT SYSTEM
ISO 9001



The RVR Logo, and others referenced RVR products and services are trademarks of RVR Elettronica in Italy, other countries or both. RVR © 1998 all rights reserved.
All other trademarks, trade names or logos used are property of their respective owners.

Manufactured by R.V.R. ELETTRONICA Italy



Appendix A Piani di montaggio, schemi elettrici, liste componenti / *Component layouts, schematics, bills of material*

Questa parte del manuale contiene i dettagli tecnici riguardanti la costruzione delle singole schede componenti il TEX52TFT. L'appendice è composta dalle seguenti sezioni:

This part of the manual contains the technical details about the different boards of the TEX52TFT. This appendix is composed of the following sections:

Description	RVR Code	Vers.	Pages
Wiring Diagrams	/	1.0	1
Main Board	SLMA0276R04V01	1.1	3
Stereo Coder Card	SLCTC30V03V01	1.1	8
Control Card	SLCNTMOS07.50	1.3	11
PA RF Power Supply	SLPS0468R01V01	1.0	14
Power Amplifier	SLRF0408R03V01	1.5	16
Panel Card	SLPC0463R02V01	1.1	19
Power Supply	KPSL4303V01B	1.0	24
Telemetry Card	SLTL0509R01V01	1.1	27
Clipper Card	SLCS0391R01V02	1.0	30
15kHz Audio Filter Card	SLAU0469R01V04	2.2	32

Document History

Date	Version	Reason	Code	Editor
10/07/2020	1.0	First Version	/	J.H. Berti
11/12/2020	1.1	SLMA0276R03V01, SLPC0463R02V01 Upgrade	/	J.H. Berti
17/06/2022	1.2	Wiring Diagrams, SLMA0276R04V01, SLRF0408R03V01, SLPC0463R05V01, SLTL0509R01V01 Upgrade	/	J.H. Berti

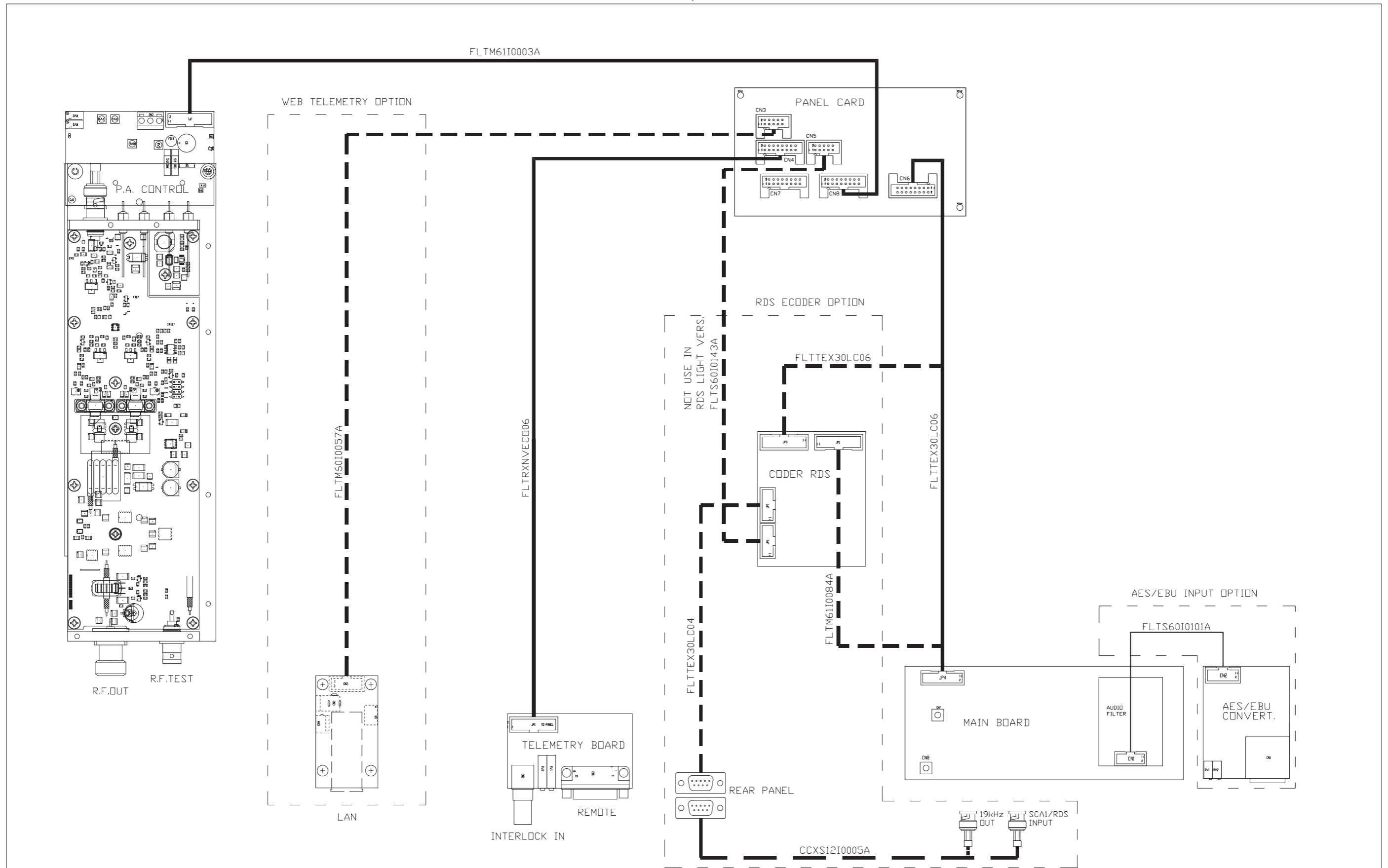

	PRODUCT NAME :	TEX32TFT - TEX52TFT	PART NAME :	WIRING DIAGRAM TEX32TFT, TEX52TFT
	DESIGNER :	G. DE DONNO	DATE :	24-06-20
ARCHIVING :	"RVRUT" SERVER, "RILASCIATI" FOLDER	PROJECT CODE :	085	DOCUMENT CODE : -----
			REVISION :	1.0
			SCALE :	/
			SIZE :	A3
			PAGE :	1 DI 2

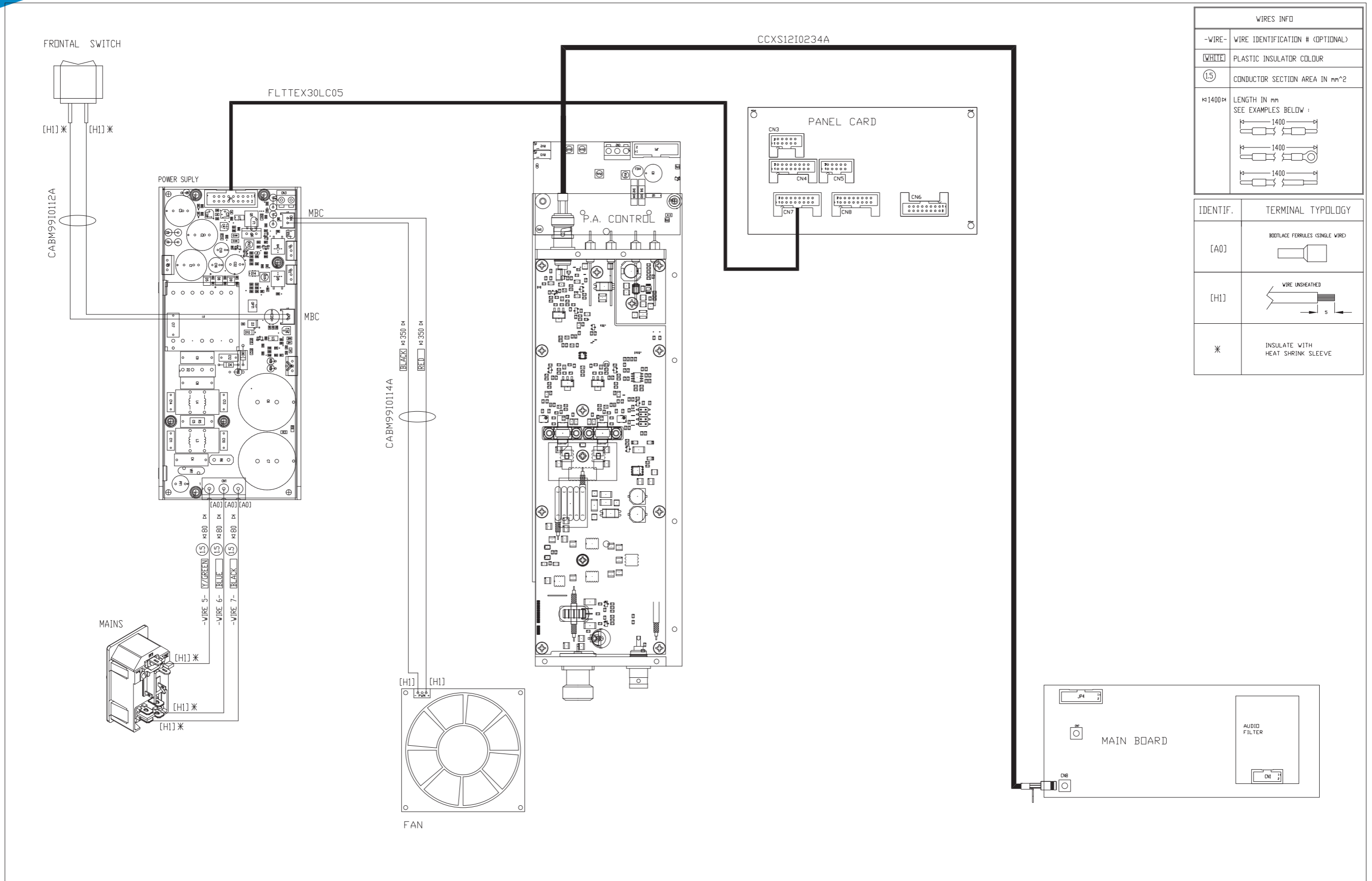

WIRES INFO	
-WIRE-	WIRE IDENTIFICATION # (OPTIONAL)
[WHITE]	PLASTIC INSULATOR COLOUR
(1.5)	CONDUCTOR SECTION AREA IN mm ²
1400	LENGTH IN mm SEE EXAMPLES BELOW :
IDENTIF.	TERMINAL TYPOLOGY
[A0]	BOOTLACE FERRULES (SINGLE WIRE)
[H1]	WIRE UNSHEATHED
*	INSULATE WITH HEAT SHRINK SLEEVE

	PRODUCT NAME : TEX32TFT - TEX52TFT	PART NAME : WIRING DIAGRAM TEX32TFT, TEX52TFT
	DESIGNER : G. DE DONNO	DATE : 24-06-20 REVISION : 1.0 SCALE : / SIZE : A3 PAGE : 2 DI 2
ARCHIVING : "RVRUT" SERVER, "RILASCIATI" FOLDER	PROJECT CODE : 085	DOCUMENT CODE : -----

SLMA0276R04V01

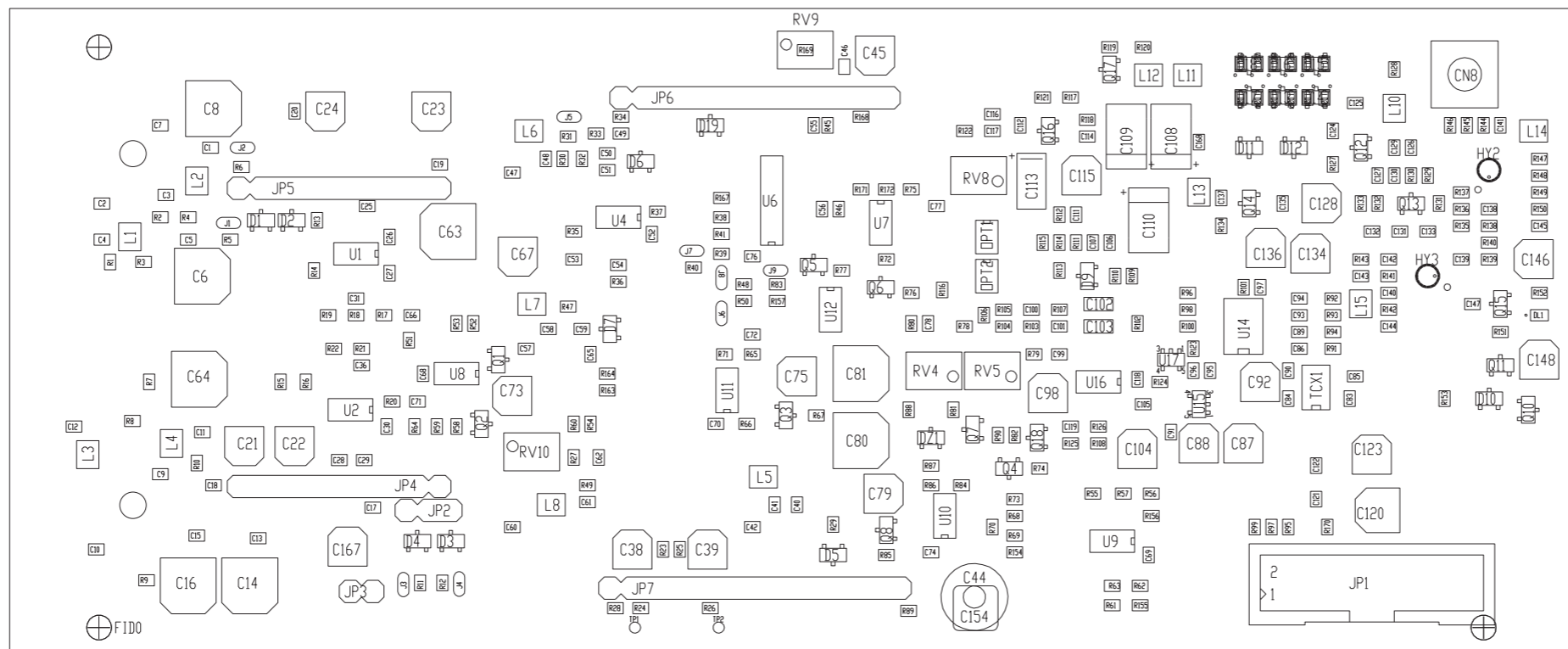
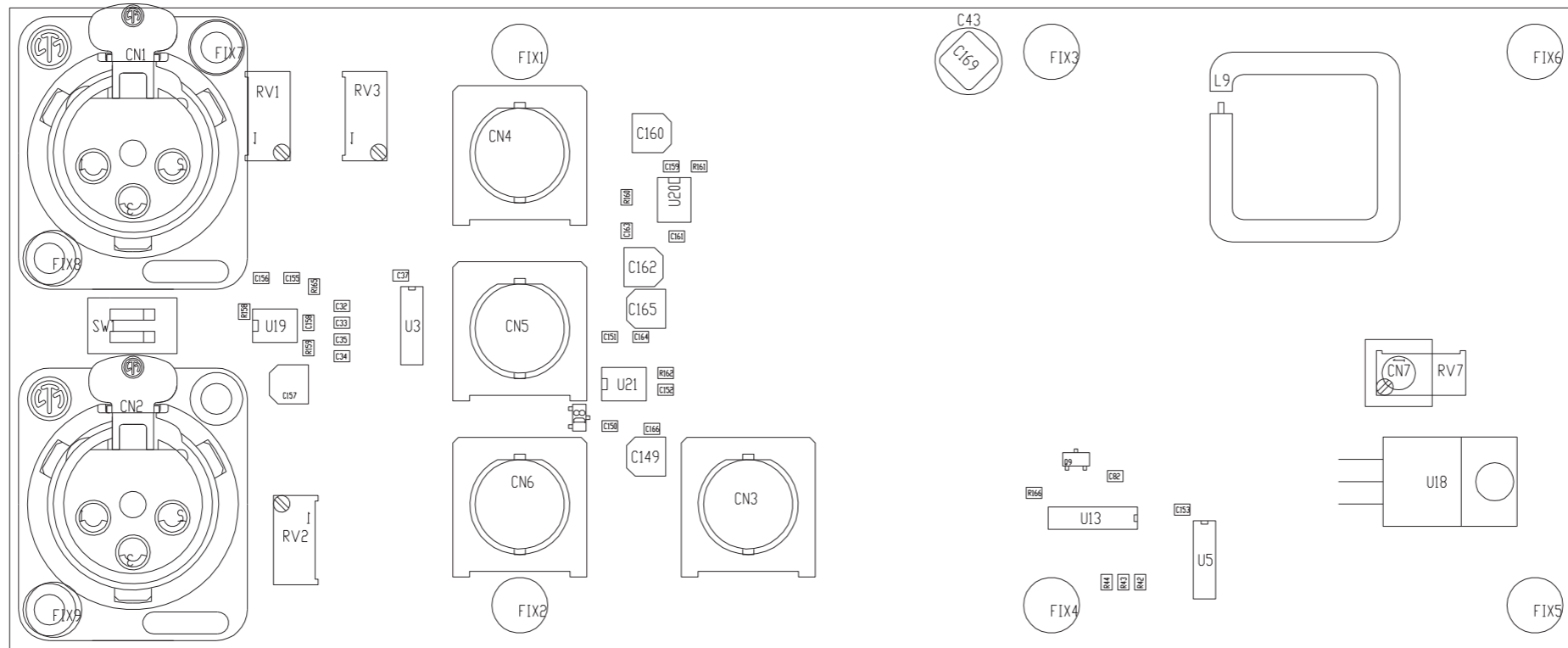

PART NAME : MAIN BOARD

DATE : 18/08/21 REVISION : 1.0 SCALE : 1:1 SIZE : A4 PAGE : 1 DI 1

DOCUMENT CODE : SLMA0276R04V**

PRODUCT NAME : TEX-TFT

DESIGNER : FRANCESCHI A.

PROJECT CODE : 252

ARCHIVING : "RVUT" SERVER, "RILASCIATI" FOLDER



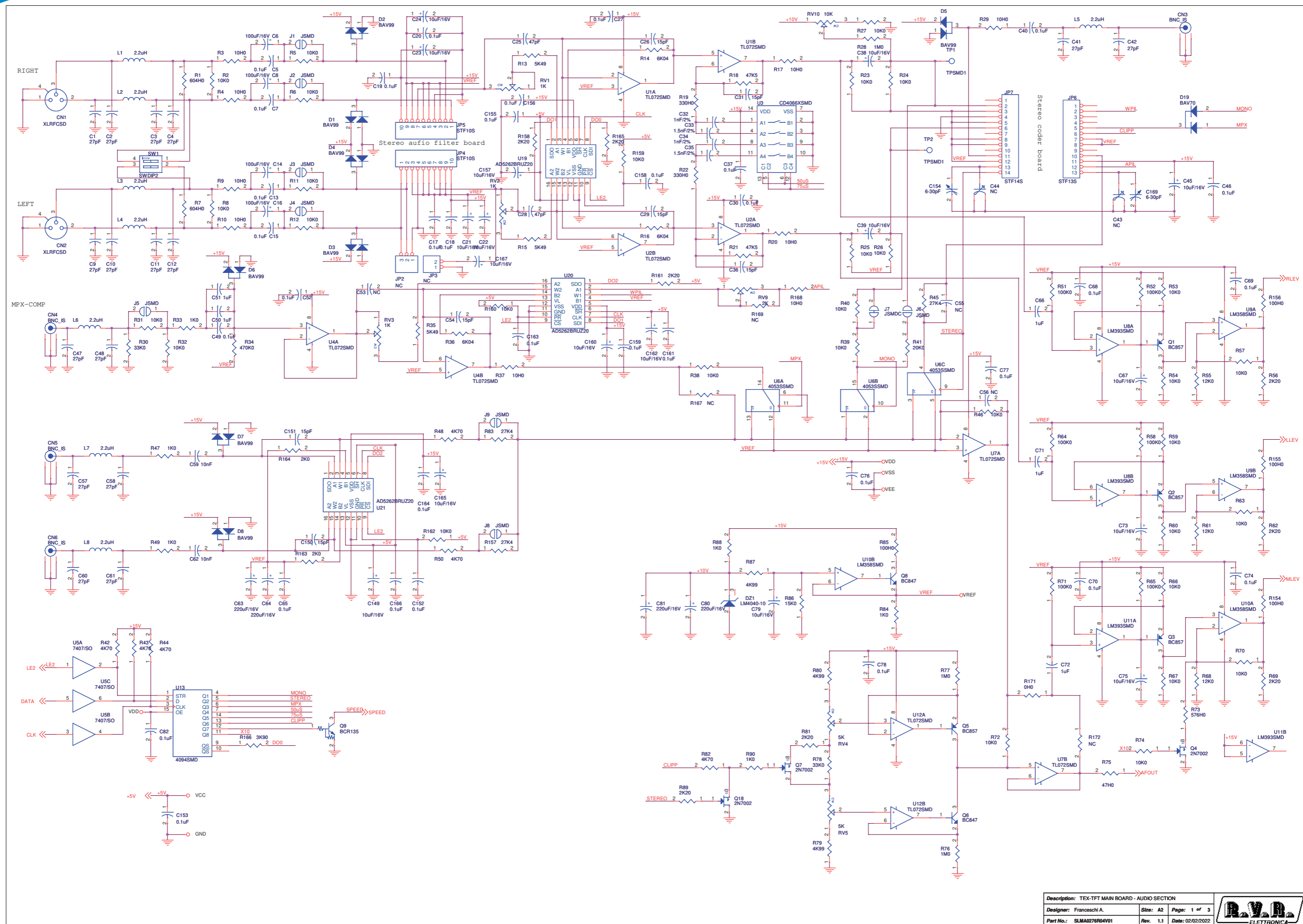

Description: TEX-TFT MAIN BOARD - AUDIO SECTION		
Designer: Franceschi A.	Size: A2	Page: 1 of 3
Part No.: SLMA0276R04V01	Rev. 1.1	Date: 02/02/2022



SLMA0276R04V01

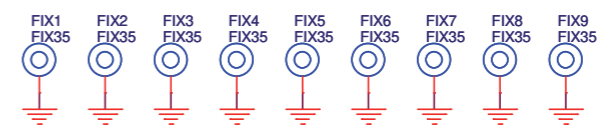
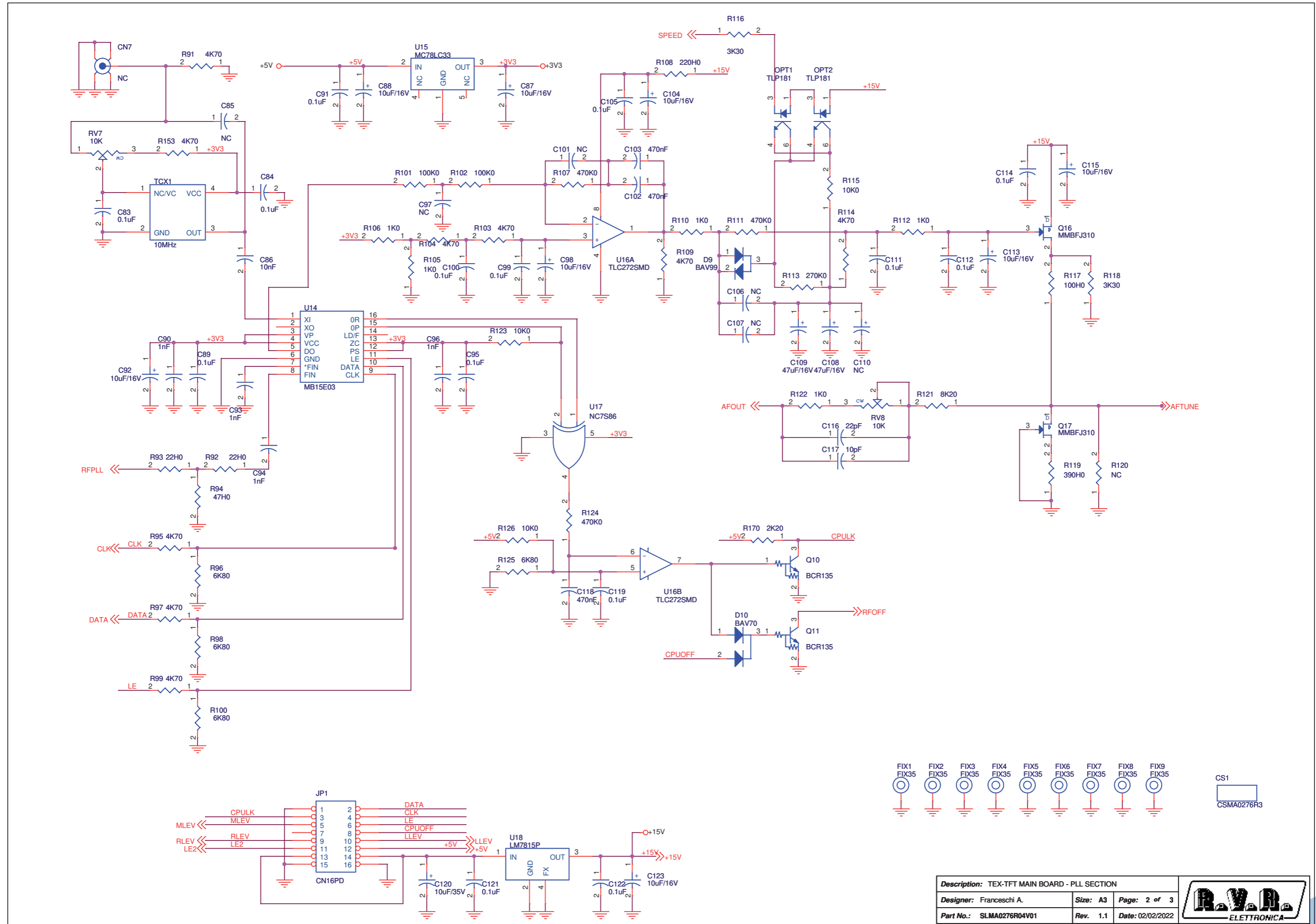

Description: TEX-TFT MAIN BOARD - PLL SECTION		
Designer: Franceschi A.	Size: A3	Page: 2 of 3
Part No.: SLMA0276R04V01	Rev. 1.1	Date: 02/02/2022



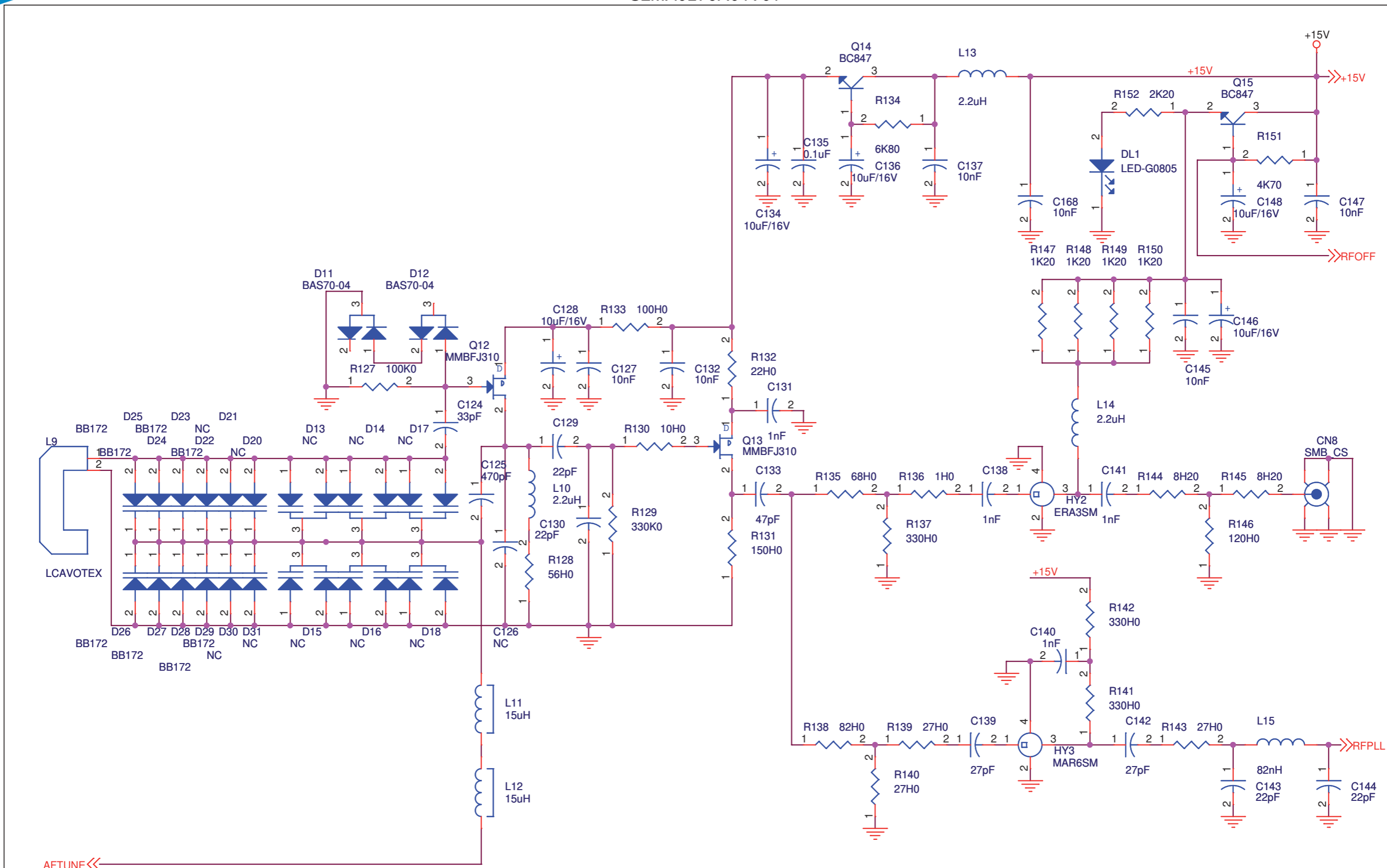

Description: TEX-TFT MAIN BOARD - VCO DRV SECTION			
Designer: Franceschi A.	Size: A4	Page: 3 of 3	
Part No.: SLMA0276R04V01	Rev.: 1.1	Date: 02/02/2022	

SLMA0276R04V01

TEX-TFT MAIN BOARD Revised: 02/02/2022
 SLMA0276R04V01 Revision: 1.1
 Franceschi A.

Item	Quantity	Reference	Part	Description
1	2	CN1, CN2	XLRFCSD	XLR fem. PCB conn.
2	4	CN3, CN4, CN5, CN6	BNC JS	Metal BNC conn.
3	1	CN7	NC	SMB pcb conn.
4	1	CN8	SMB_CS	SMB pcb conn.
5	1	CS1	CSMA0276R3	Printed Circuit board
6	18	C1, C2, C3, C4, C9, C10, C11, C12, C41, C42, C47, C48, C57, C58, C60, C61, C139, C142	27pF	0805 SMD capacitor
7	49	C5, C7, C13, C15, C17, C18, C19, C20, C27, C30, C37, C40, C46, C49, C52, C65, C68, C69, 0.1uF, C70, C74, C76, C77, C78, C82, C83, C84, C89, C91, C95, C99, C100, C105, C111, C112, C114, C119, C121, C122, C135, C152, C153, C155, C156, C158, C159, C161, C163, C164, C166		0805 SMD capacitor
8	4	C6, C8, C14, C16	100uF/16V	SMD electr. cap. 6.3mm
9	29	C21, C22, C23, C24, C38, C39, C45, C67, C73, C75, C79, C87, C88, C92, C98, C104, C115, 10uF/16V, C123, C128, C134, C136, C146, C148, C149, C157, C160, C162, C165, C167		SMD electr. cap. 4mm
10	3	C25, C28, C133	47pF	0805 SMD capacitor
11	7	C26, C29, C31, C36, C54, C150, C151	15pF	0805 SMD capacitor
12	2	C32, C34	1nF/2%	0805 COG SMD capacitor
13	2	C33, C35	1.5nF/2%	0805 COG SMD capacitor
14	2	C43, C44	NC	Ceramic comp. dia. 7mm
15	5	C50, C51, C66, C71, C72	1uF	0805 SMD capacitor
16	9	C53, C55, C56, C85, C97, C101, C106, C107, C126	NC	0805 SMD capacitor
17	9	C59, C62, C86, C127, C132, C137, C145, C147, C168	10nF	0805 SMD capacitor
18	4	C63, C64, C80, C81	220uF/16V	SMD electr. cap. 6.3mm
19	8	C90, C93, C94, C96, C131, C138, C140, C141	1nF	0805 SMD capacitor
20	2	C102, C103	470nF	1206 SMD capacitor
21	2	C108, C109	47uF/16V	SMD tantalum cap. size D
22	1	C110	NC	SMD tantalum cap. size D
23	1	C113	10uF/16V	SMD tantalum cap. size C
24	5	C116, C129, C130, C143, C144	22pF	0805 SMD capacitor
25	1	C117	10pF	0805 SMD capacitor
26	1	C118	470nF	0805 SMD capacitor
27	1	C120	10uF/35V	SMD electr. cap. 5mm
28	1	C124	33pF	0805 SMD capacitor
29	1	C125	470pF	0805 SMD capacitor
30	2	C154, C169	6-30pF	Var. comp. Murata TZB4A
31	1	DL1	LED-G0805	Green LED SMD 0805
32	1	DZ1	LM4040-10	SMD SOT23 precision Zener
33	9	D1, D2, D3, D4, D5, D6, D7, D8, D9	BAV99	Dual diode SMD SOT23
34	2	D10, D19	BAV70	Dual diode SMD SOT23
35	2	D11, D12	BAS70-04	Dual diode SMD SOT23
36	6	D13, D14, D15, D16, D17, D18	NC	Dual diode Varicap SMD SOT23
37	4	D20, D21, D30, D31	NC	Varicap diode SOD323
38	8	D22, D23, D24, D25, D26, D27, D28, D29	BB172	Varicap diode SOD323
39	9	FIX1, FIX2, FIX3, FIX4, FIX5, FIX6, FIX7, FIX8, FIX9	FIX35	3.5mm Fixing hole
40	1	HY2	ERA3SM	Hybrid MAR/ERA
41	1	HY3	MAR6SM	Hybrid MAR/ERA
42	1	JP1	CN16PD	16 way pcb conn. with holder
43	1	JP2	NC	Male strip 3 pin
44	1	JP3	NC	Male strip 2 pin
45	2	JP4, JP5	STF10S	Female strip 10 pin
46	1	JP6	STF13S	Female strip 13 pin
47	1	JP7	STF14S	Female strip 14 pin
48	8	J1, J2, J3, J4, J5, J6, J8, J9	J5MD	2 pad SMD jumper
49	1	J7	J5MDC	2 pad SMD jumper closed
50	11	L1, L2, L3, L4, L5, L6, L7, L8, L10, L13, L14	2.2uH	SMD inductor 3225 (1210)
51	1	L9	LCAVOTEX	Inductor Cable for TEX
52	2	L11, L12	15uH	SMD inductor 3225 (1210) shielded
53	1	L15	82nH	SMD inductor 3225 (1210)
54	2	OPT1, OPT2	TLP181	Optocoupler SMD SO6
55	4	Q1, Q2, Q3, Q5	BC857	PNP trans. SOT23
56	3	Q4, Q7, Q18	2N7002	Trans. FET SOT23
57	4	Q6, Q8, Q14, Q15	BC847	NPN trans. SOT23
58	3	Q9, Q10, Q11	BCR135	Digital NPN trans. SOT23
59	4	Q12, Q13, Q16, Q17	MMBFJ310	Trans. FET SOT23
60	3	RV1, RV2, RV3	1K	Trimmer Rg V 3296W
61	2	RV4, RV5	5K	Trimmer Rg V 3269W SMD
62	1	RV7	10K	Trimmer Rg V 3296W
63	2	RV8, RV10	10K	Trimmer Rg V 3269W SMD
64	1	RV9	2K	Trimmer Rg V 3269W SMD

Item	Quantity	Reference	Part	Description
65	2	R1, R7	604H0	0805 SMD res.
66	34	R2, R5, R6, R8, R11, R12, R23, R24, R25, R26, R27, R31, R32, R38, R39, R40, R46, R53, R54, R57, R59, R60, R63, R66, R67, R70, R72, R74, R115, R123, R126, R159, R160, R162	10K0	0805 SMD res.
67	10	R3, R4, R9, R10, R17, R20, R29, R37, R130, R168	10H0	0805 SMD res.
68	3	R13, R15, R35	5K49	0805 SMD res.
69	3	R14, R16, R36	6K04	0805 SMD res.
70	2	R18, R21	47K5	0805 SMD res.
71	5	R19, R22, R137, R141, R142	330H0	0805 SMD res.
72	3	R28, R76, R77	1M0	0805 SMD res.
73	2	R30, R78	33K0	0805 SMD res.
74	11	R33, R47, R49, R84, R88, R90, R105, R106, R110, R112, R122	1K0	0805 SMD res.
75	4	R34, R107, R111, R124	470K0	0805 SMD res.
76	1	R41	20K0	0805 SMD res.
77	16	R42, R43, R44, R48, R50, R82, R91, R95, R97, R99, R103, R104, R109, R114, R151, R153	4K70	0805 SMD res.
78	3	R45, R83, R157	27K4	0805 SMD res.
79	9	R51, R52, R58, R64, R65, R71, R101, R102, R127	100K0	0805 SMD res.
80	3	R55, R61, R68	12K0	0805 SMD res.
81	10	R56, R62, R69, R81, R89, R152, R158, R161, R165, R170	2K20	0805 SMD res.
82	1	R73	576H0	0805 SMD res.
83	2	R75, R94	47H0	0805 SMD res.
84	3	R79, R80, R87	4K99	0805 SMD res.
85	6	R85, R117, R133, R154, R155, R156	100H0	0805 SMD res.
86	1	R86	15K0	0805 SMD res.
87	3	R92, R93, R132	22H0	0805 SMD res.
88	5	R96, R98, R100, R125, R134	6K80	0805 SMD res.
89	1	R108	220H0	0805 SMD res.
90	1	R113	270K0	0805 SMD res.
91	2	R116, R118	3K30	0805 SMD res.
92	1	R119	390H0	0805 SMD res.
93	4	R120, R167, R169, R172	NC	0805 SMD res.
94	1	R121	8K20	0805 SMD res.
95	1	R128	56H0	0805 SMD res.
96	1	R129	330K0	0805 SMD res.
97	1	R131	150H0	0805 SMD res.
98	1	R135	68H0	0805 SMD res.
99	1	R136	1H0	0805 SMD res.
100	1	R138	82H0	0805 SMD res.
101	3	R139, R140, R143	27H0	0805 SMD res.
102	2	R144, R145	8H20	0805 SMD res.
103	1	R146	120H0	0805 SMD res.
104	4	R147, R148, R149, R150	1K20	0805 SMD res.
105	2	R163, R164	2K0	0805 SMD res.
106	1	R166	3K90	0805 SMD res.
107	1	R171	0H0	0805 SMD res.
108	1	SW1	SWDIP2	2 ways switch slide dip
109	1	TCX1	10MHz	TCXO SMD 5x3.2mm
110	2	TP1, TP2	TPSMD1	Piazzola SMD d.1mm
111	5	U1, U2, U4, U7, U12	TLO72SMD	Dual Op. SMD SO8
112	1	U3	CD4066XSMD	Analog Switch SMD SO14
113	1	U5	7407/SO	Hex buffer OC SMD SO14
114	1	U6	4053SSMD	Analog Switch SMD SO16
115	2	U8, U11	LM393SMD	Dual Comp. SMD SO8
116	2	U9, U10	LM358SMD	Dual Op. SMD SO8
117	1	U13	4094SMD	Shift Reg. SMD SO16
118	1	U14	MB15E03	Integrated PLL
119	1	U15	MC78LC33	Stab. SMD SOT23-5
120	1	U16	TLC272SMD	Dual Op. SMD SO8
121	1	U17	NC7S86	XOR Port
122	1	U18	LM7815P	Voltage reg. TO220
123	3	U19, U20, U21	ADS262BRUZZ0	Dual 256 pos. dig. pot.

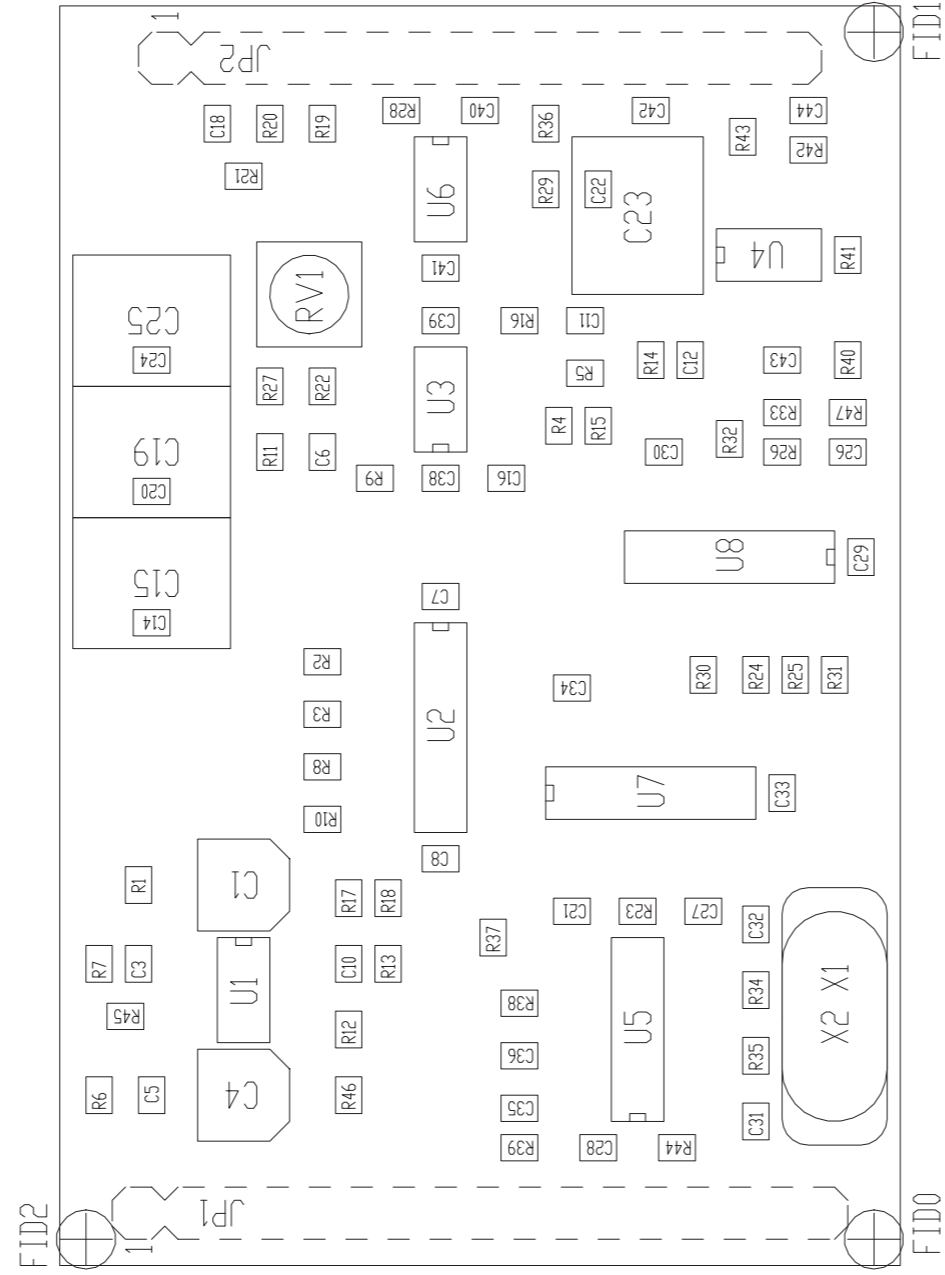

PRODUCT NAME : SERED CODER	PART NAME : CTC30 CODER CARD
DESIGNER : FRANCESCHI A.	DATE : 26/01/15
ARCHIVING : "RVRUT" SERVER, "RILASCIATI" FOLDER	REVISION : 1.0
PROJECT CODE : -	SCALE : 2:1
	SIZE : A4
	PAGE : 1
	DI : 1
	DOCUMENT CODE : SLCTC30V03V**

SLCTC30V03V01

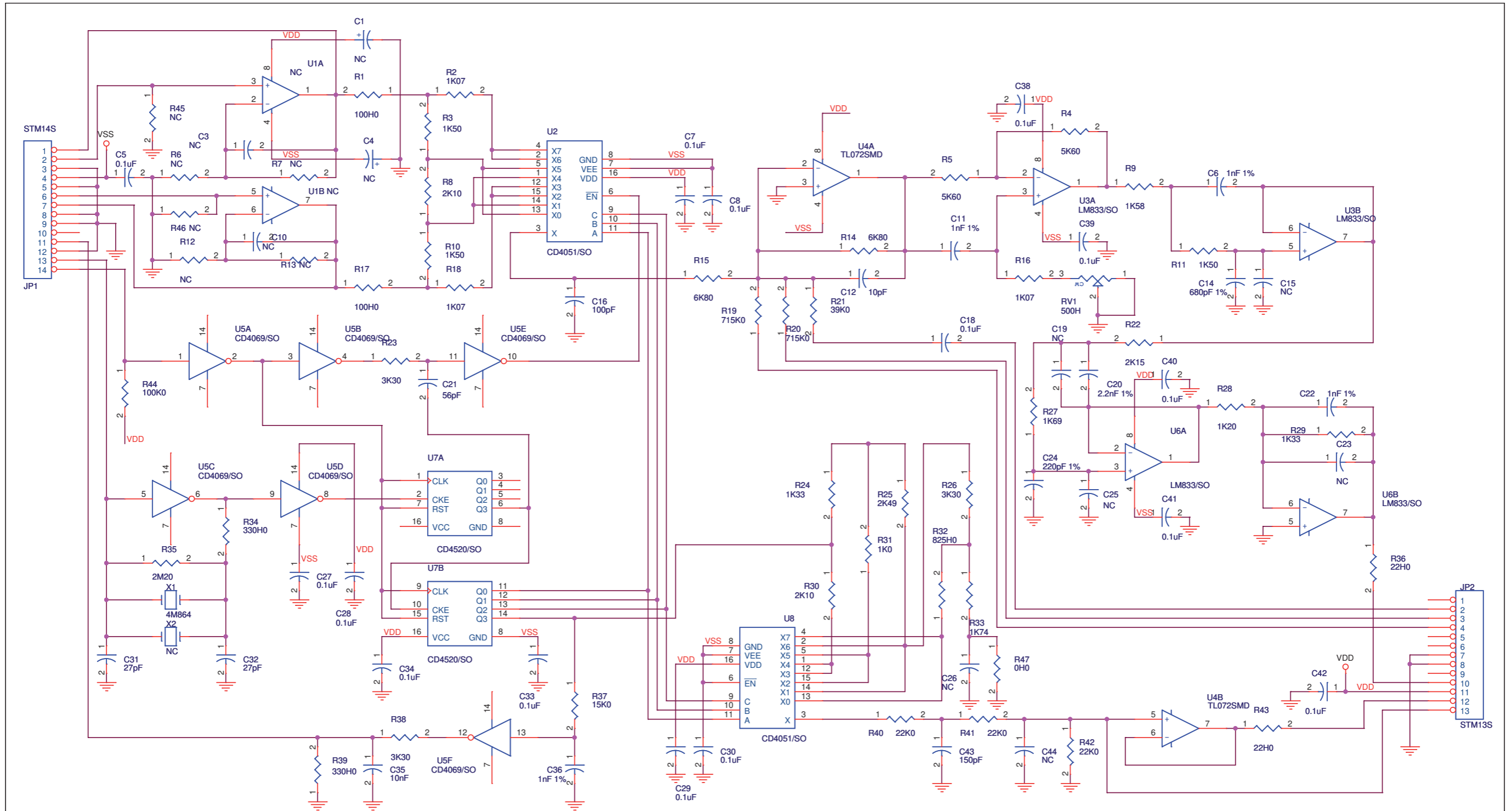

CS1
CSCTC30V03

Description: Coder Card		
Designer: Franceschi A.	Size: A3	Page: 1 of 1
Part No.: SLCTC30V03V01	Rev.: 1.1	Date: 26/01/2015



SLCTC30V03V01

Coder Card Revised: 26/01/2015
 SLCTC30V03V01 Revision: 1.1
 Franceschi A.

Item	Quantity	Reference	Part	Description
1	1	C51	CSCTC30V03	Circuito stampato
2	2	C1,C4	NC	Cond. Elett. SMD d. 4mm
3	3	C3,C10,C26	NC	Cond. SMD 0805
4	15	C5,C7,C8,C18,C27,C28,C29, C30,C33,C34,C38,C39,C40, C41,C42	0.1uF	Cond. SMD 0805
5	4	C6,C11,C22,C36	1nF 1%	Cond. SMD 0805 COG
6	1	C12	10pF	Cond. SMD 0805
7	1	C14	680pF 1%	Cond. SMD 0805 COG
8	4	C15,C19,C23,C25	NC	Cond. Poliestere p 5mm (5*7mm)
9	1	C16	100pF	Cond. SMD 0805
10	1	C20	2.2nF 1%	Cond. SMD 0805 COG
11	1	C21	56pF	Cond. SMD 0805
12	1	C24	220pF 1%	Cond. SMD 0805 COG
13	2	C31,C32	27pF	Cond. SMD 0805
14	1	C35	10nF	Cond. SMD 0805
15	1	C43	150pF	Cond. SMD 0805
16	1	C44	NC	Cond. SMD 0805
17	1	JP1	STM14S	Strip maschio 14 pin
18	1	JP2	STM13S	Strip maschio 13 pin
19	1	RV1	500H	Trimmer SMD
20	2	R1,R17	100H0	Res. SMD 0805
21	3	R2,R16,R18	1K07	Res. SMD 0805
22	3	R3,R10,R11	1K50	Res. SMD 0805
23	2	R4,R5	5K60	Res. SMD 0805
24	6	R6,R7,R12,R13,R45,R46	NC	Res. SMD 0805
25	2	R8,R30	2K10	Res. SMD 0805
26	1	R9	1K58	Res. SMD 0805
27	2	R14,R15	6K80	Res. SMD 0805
28	2	R19,R20	715K0	Res. SMD 0805
29	1	R21	39K0	Res. SMD 0805
30	1	R22	2K15	Res. SMD 0805
31	3	R23,R26,R38	3K30	Res. SMD 0805
32	2	R24,R29	1K33	Res. SMD 0805
33	1	R25	2K49	Res. SMD 0805
34	1	R27	1K69	Res. SMD 0805
35	1	R28	1K20	Res. SMD 0805
36	1	R31	1K0	Res. SMD 0805
37	1	R32	825H0	Res. SMD 0805
38	1	R33	1K74	Res. SMD 0805
39	2	R34,R39	330H0	Res. SMD 0805
40	1	R35	2M20	Res. SMD 0805
41	2	R36,R43	22H0	Res. SMD 0805
42	1	R37	15K0	Res. SMD 0805

43	3	R40,R41,R42	22K0	Res. SMD 0805
44	1	R44	100K0	Res. SMD 0805
45	1	R47	OH0	Res. SMD 0805
46	1	U1	NC	Dual Op. SMD SO8
47	2	U2,U8	CD4051/SO	Analog Switch SMD SO16
48	2	U3,U6	LM833/SO	Dual Op. SMD SO8
49	1	U4	TL072SMD	Dual Op. SMD SO8
50	1	U5	CD4069/SO	Hex inverter SO14
51	1	U7	CD4520/SO	Dual binary counter
52	1	X1	4M864	Quarzo SMD HC495SMD
53	1	X2	NC	Quarzo HC18

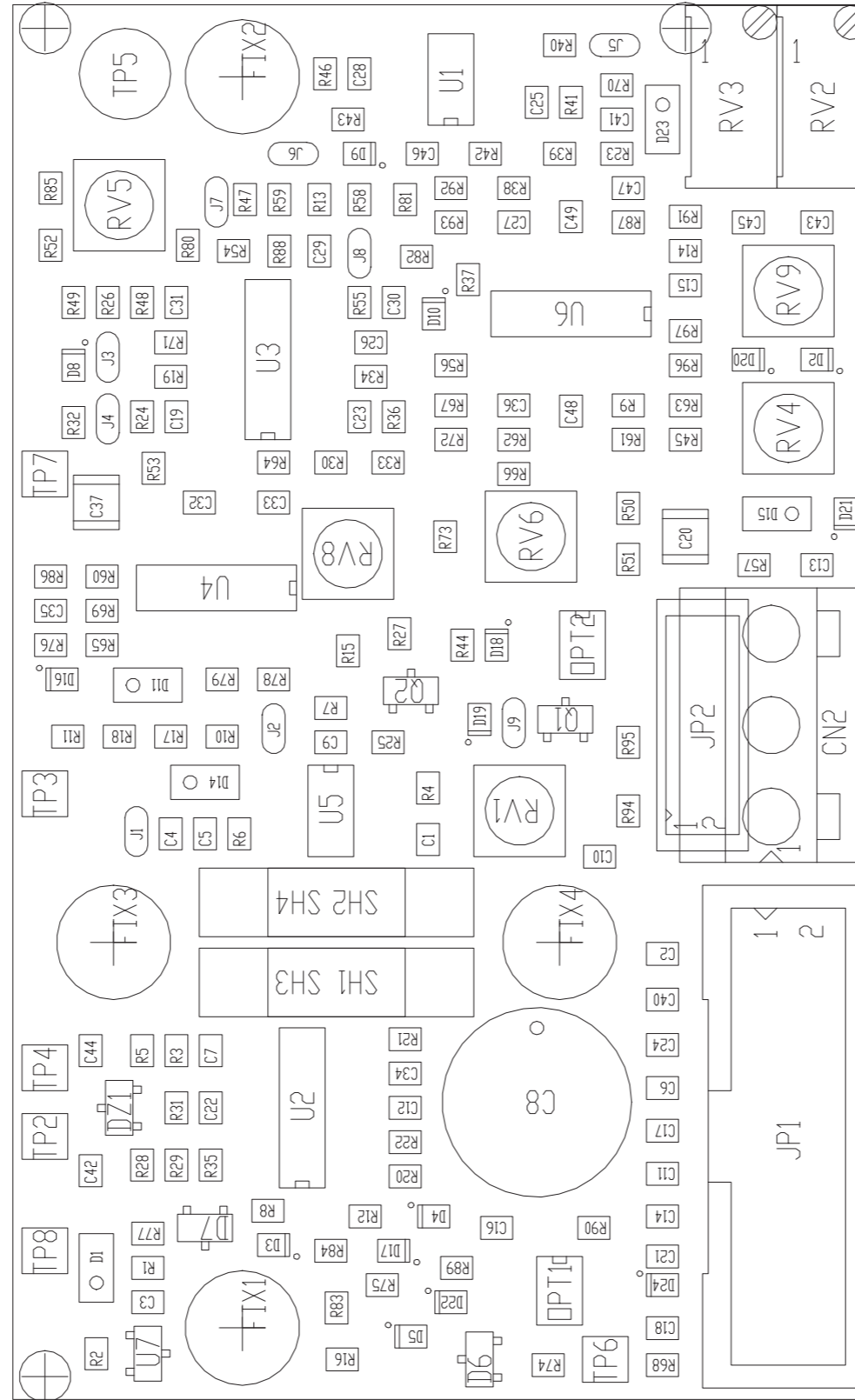

PRODUCT NAME : TEX

DESIGNER : FRANCESCHI A.

ARCHIVING : "RVRUT" SERVER, "RILASCIATI" FOLDER

PART NAME : CNTMOS PA RF R.07

DATE : 18/05/16

REVISION : 1.0

SCALE : 1:1

SIZE : A4

PAGE : 1

DI : 1

PROJECT CODE : <

DOCUMENT CODE : SLCNTMOS07.**

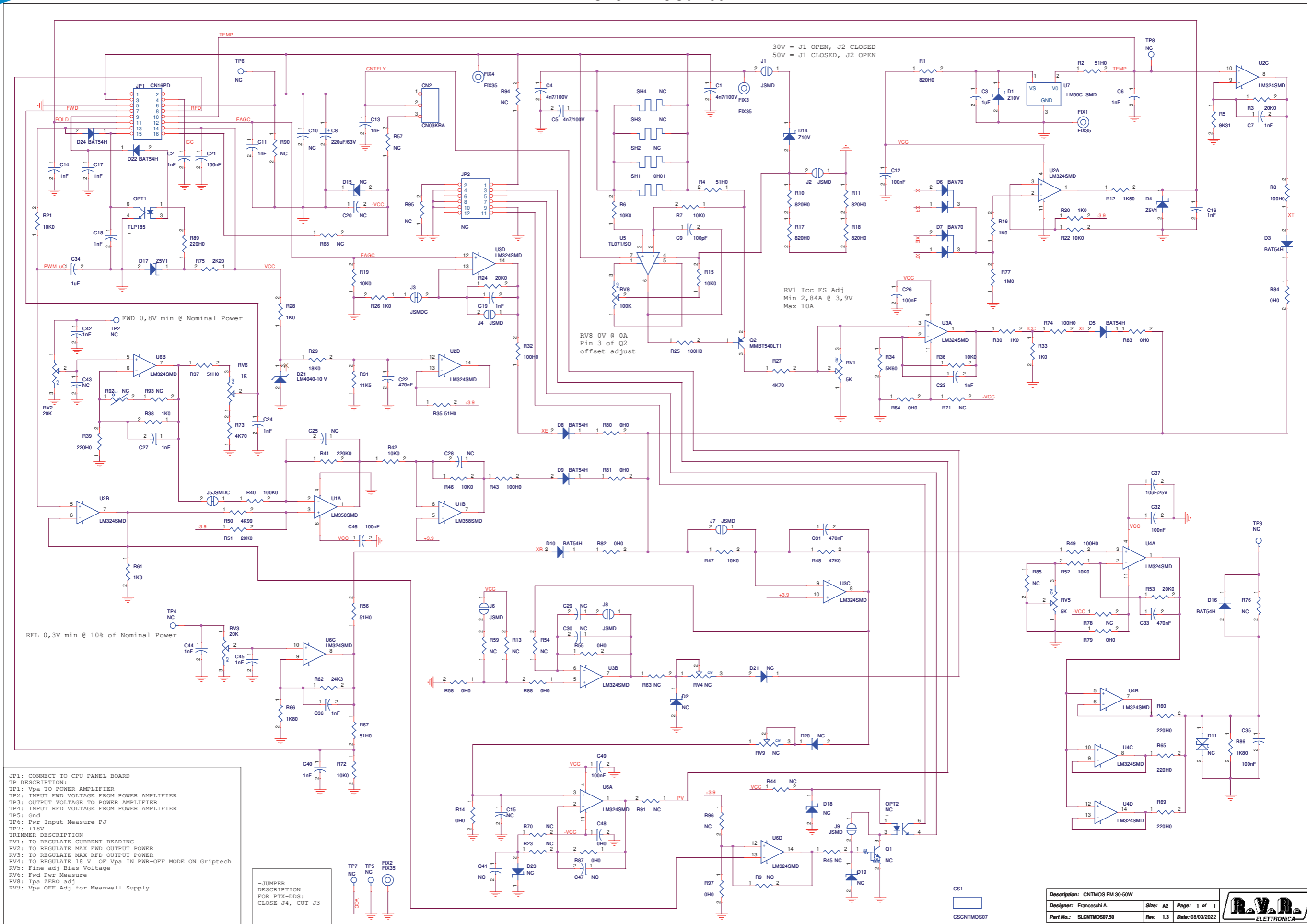

SLCNTMOS07.50

CNTMOS FM 30-50W Revised: Tuesday, March 08, 2022
 SLCNTMOS07.50 Revision: 1.3
 Franceschi A.

Item	Quantity	Reference	Part	Description
1	1	CN2	CN03KRA	Conn. tipo KRA a 3 poli
2	1	CS1	CSCNTMOS07	Circuito stampato
3	3	C1, C4, C5	4n7/100V	Cond. SMD 0805
4	18	C2, C6, C7, C11, C13, C14, C16, C17, C18, C19, C23, C24, C27, C36, C40, C42, C44, C45	1nF	Cond. SMD 0805
5	2	C3, C34	1uF	Cond. SMD 0805
6	1	C8	220uF/63V	Cond. Elettr. Dia 10 P5.08
7	1	C9	100pF	Cond. SMD 0805
8	9	C10, C15, C25, C28, C29, C30, C41, C43, C47	NC	Cond. SMD 0805
9	7	C12, C21, C26, C32, C35, C46, C49	100nF	Cond. SMD 0805
10	1	C20	NC	Cond. SMD 1210
11	3	C22, C31, C33	470nF	Cond. SMD 0805
12	1	C37	10uF/25V	Cond. SMD 1210
13	1	C48	0H0	Cond. SMD 0805
14	1	DZ1	LM4040-10 V	Diodi Zener SMD SOT23
15	2	D1, D14	Z10V	MINIMELF SMD Zener Diode
16	3	D2, D18, D19	NC	SOD323 Zener Diode
17	8	D3, D5, D8, D9, D10, D16, D22, D24	BAT54H	SOD323 SMD Diode
18	2	D4, D17	Z5V1	SOD323 Zener Diode
19	2	D6, D7	BAV70	Doppio Diode SMD SOT23
20	1	D11	NC	Transzorbo SMA
21	2	D15, D23	NC	MINIMELF SMD Zener Diode
22	2	D20, D21	NC	SOD323 SMD Diode
23	4	FIX1, FIX2, FIX3, FIX4	FIX35	Foro fissaggio 3.5mm
24	1	JP1	CN16PD	Conn.M.C.S.Dritto 16P alette.
25	1	JP2	NC	Conn. 12 poli DF11 12pin p. 2mm
26	7	J1, J2, J4, J6, J7, J8, J9	J5MD	Pad SMD a saldare
27	2	J3, J5	J5MDC	Pad SMD a saldare chiuso
28	1	OPT1	TLP185	Optocoupler SMD SO6
29	1	OPT2	NC	Optocoupler SMD SO6
30	1	Q1	NC	Trans./Res. NPN SOT23
31	1	Q2	MMBT540LT1	Trans. PNP SOT23
32	2	RV1, RV5	5K	Trimmer SMD
33	2	RV2, RV3	20K	Trimmer Rg V 3296W
34	2	RV4, RV9	NC	Trimmer SMD
35	1	RV6	1K	Trimmer SMD
36	1	RV8	100K	Trimmer SMD
37	5	R1, R10, R11, R17, R18	820H0	Res. SMD 0805 1%
38	6	R2, R4, R35, R37, R56, R67	51H0	Res. SMD 0805 1%
39	4	R3, R24, R51, R53	20K0	Res. SMD 0805 1%
40	1	R5	9K31	Res. SMD 0805 1%
41	12	R6, R7, R15, R19, R21, R22, R36, R42, R46, R47, R52, R72	10K0	Res. SMD 0805 1%
42	6	R8, R25, R32, R43, R49, R74	100H0	Res. SMD 0805 1%
43	21	R9, R13, R23, R44, R45, R54, R57, R59, R63, R68, R70, R71, R76, R78, R85, R90, R91, R93, R94, R95, R96	NC	Res. SMD 0805 1%
44	1	R12	1K50	Res. SMD 0805 1%
45	13	R14, R55, R58, R64, R79, R80, R81, R82, R83, R84, R87, R88, R97	0H0	Res. SMD 0805 1%
46	8	R16, R20, R26, R28, R30, R33, R38, R61	1K0	Res. SMD 0805 1%
47	2	R27, R73	4K70	Res. SMD 0805 1%
48	1	R29	18K0	Res. SMD 0805 1%
49	1	R31	11K5	Res. SMD 0805 1%
50	1	R34	5K60	Res. SMD 0805 1%
51	5	R39, R60, R65, R69, R89	220H0	Res. SMD 0805 1%
52	1	R40	100K0	Res. SMD 0805 1%
53	1	R41	220K0	Res. SMD 0805 1%
54	1	R48	47K0	Res. SMD 0805 1%
55	1	R50	4K99	Res. SMD 0805 1%
56	1	R62	24K3	Res. SMD 0805 1%
57	2	R66, R86	1K80	Res. SMD 0805 1%
58	1	R75	2K20	Res. SMD 0805 1%
59	1	R77	1M0	Res. SMD 0805 1%
60	1	R92	NC	Res. NTC SMD 0805
61	1	SH1	0H01	Shunt passo 15.2mm fori 2mm
62	1	SH2	NC	Shunt passo 15.2mm fori 2mm
63	2	SH3, SH4	NC	Shunt SMD 2512
64	6	TP2, TP3, TP4, TP6, TP7, TP8	NC	Foro dia. 1mm
65	1	TP5	NC	Foro dia. 2mm

Item	Quantity	Reference	Part	Description
66	1	U1	LM358SMD	Dual Op. SMD SO8
67	4	U2, U3, U4, U6	LM324SMD	Quad Op. SMD SO14
68	1	U5	TL071/SO	Single Op. SMD SO8
69	1	U7	LM50C_SMD	Temperature sensor

SLPS0468R01V01

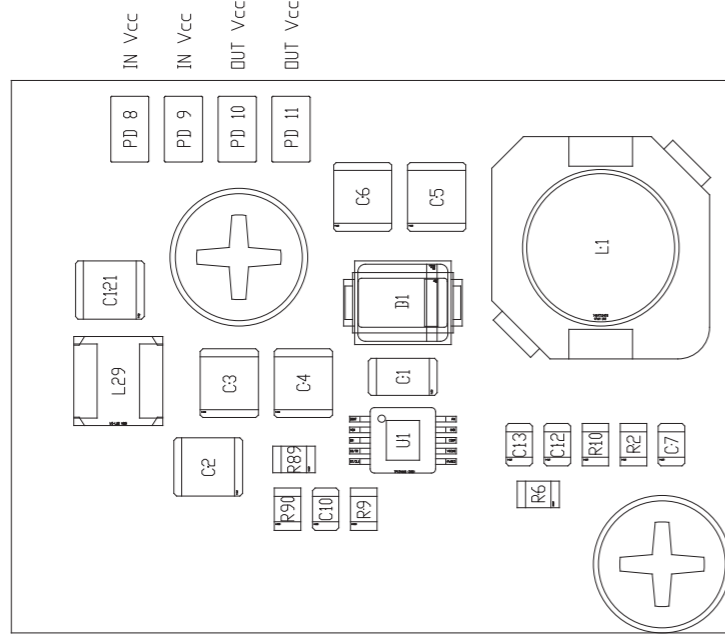

DESCRIPTION : POWER SUPPLY PA RF 50W 50V
 DESIGNER : FRANCESCHI A.
 PART CODE : SLPS0468R01V**
 DATE: 19/04/2017 | REVISION: 1.0 | SCALE: 3:1 | SIZE: A4 | PAGINA: 1 DI 1

DESCRIPTION : POWER SUPPLY PA RF 50W 50V
 DESIGNER : FRANCESCHI A.
 PART CODE : SLPS0468R01V**
 DATE: 19/04/2017 | REVISION: 1.0 | SCALE: 3:1 | SIZE: A4 | PAGINA: 1 DI 1

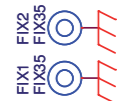
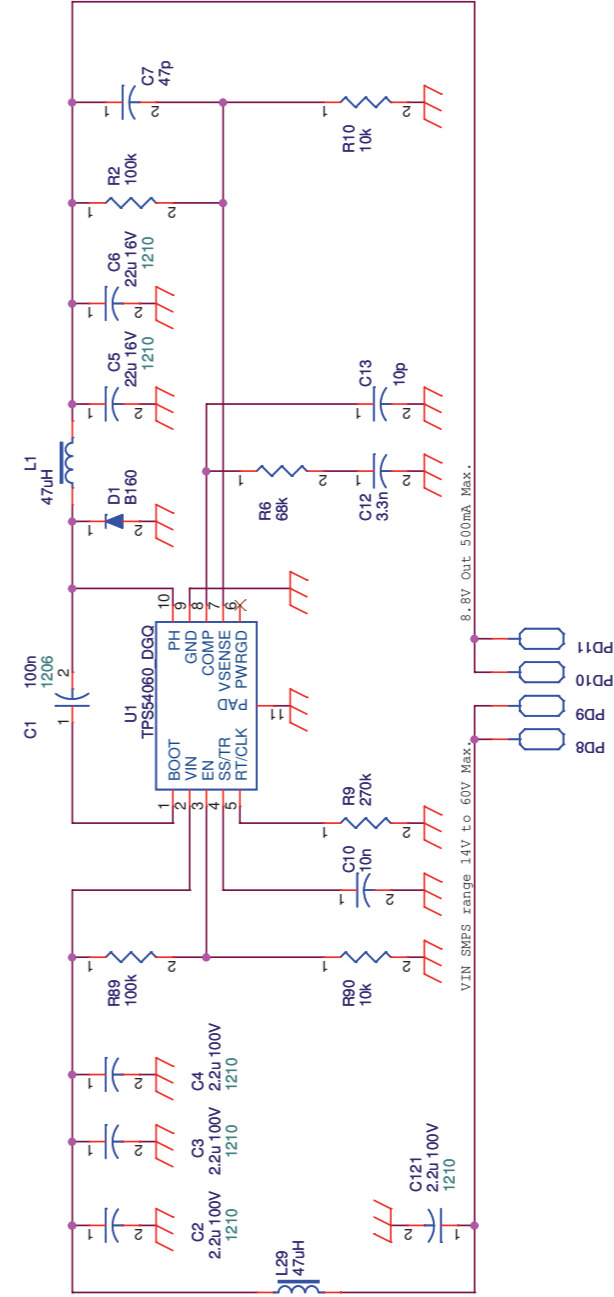

Description: POWER SUPPLY PA RF 50W 50V	
Designer: Franceschi A.	Size: A4
Part No.: SLPS0468R01V01	Rev. 1.0
Page: 1 of 1	Date: 19/04/2017

SLPS0468R01V01

POWER SUPPLY PA RF 50W 50V
 SLPS0468R01V01
 Revision: 1.0
 Franceschi A.
 19/04/2017

Item	Quantity	Reference	Part	Description
3	1	CS1	CSPS0468R1	Circuito stampato PA
5	1	C1	100n	Cond. SMD 1206
6	4	C2,C3,C4,C121	2.2u 100V	Capacitor SMD 1210 MLCC X7R 100V
7	2	C5,C6	22u 16V	Capacitor SMD 1210 MLCC X7R 16V
8	1	C7	47p	Cond. SMD 0805 COG
9	1	C10	10n	SMD 0805 MLCC X7R
11	1	C12	3.3n	SMD 0805 MLCC X7R
12	1	C13	10p	Cond. SMD 0805 COG
45	1	D1	B160	SMA Size SCHOTTKY Diode
51	4	FID4,FID5,FID6,FID7	FID	Fiducial CS
52	2	FIX1,FIX2	FIX35	
57	1	L1	47uH	PWR Ind Wurth E 7447713470
73	1	L29	47uH	PWR Ind WE 74404042470
75	4	PD8,PD9,PD10,PD11	PAD	Pad for connection
84	2	R2,R89	100k	Res. SMD 0805
88	1	R6	68k	Res. SMD 0805
91	1	R9	270k	Res. SMD 0805
92	2	R10,R90	10k	Res. SMD 0805
130	1	U1	TPS54060_DGQ	Step-Down DC2DC Converter

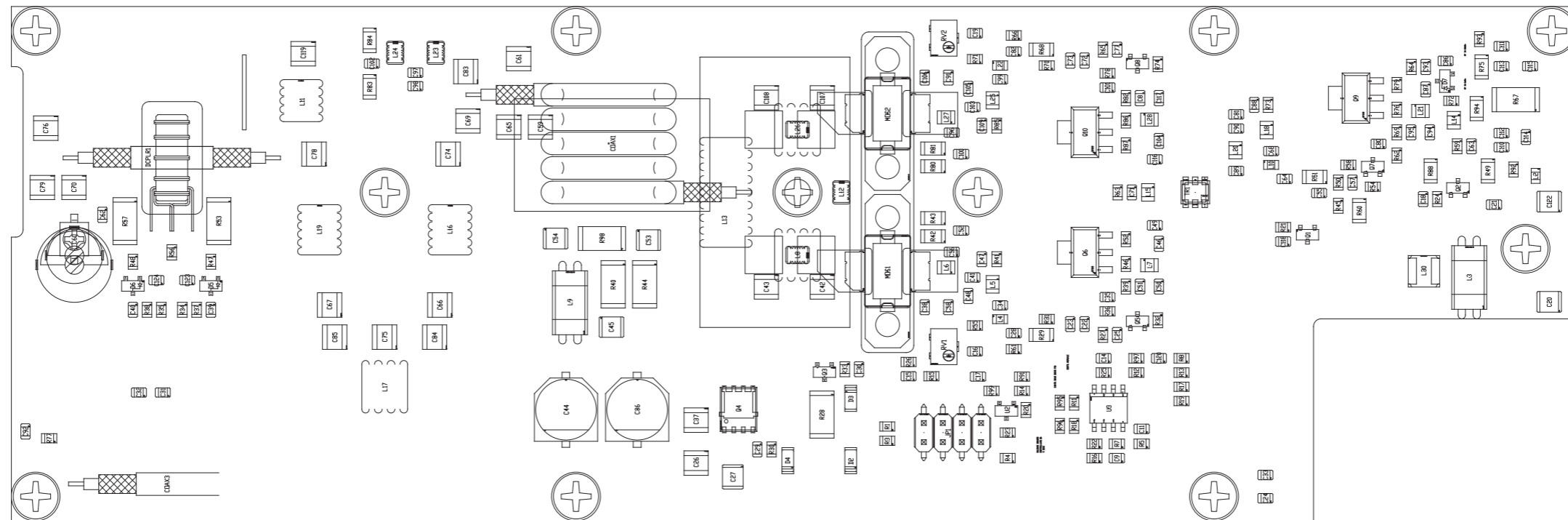

DESCRIPTION : RF PA 50W 50V FM BAND

PART CODE : SLRF0408R03V01

DESIGNER : FRANCESCHI A.

DATE: 19/04/2017 | REVISION: 1.0 | SCALE: 1:1 | SIZE: A4 | PAGINA: 1 DI 1

SLRF0408R03V01

RF PA 50W 50V FM Band Revised: 04/03/2022
 SLRF0408R03V01 Revision: 1.5
 Franceschi/Tommasi

Item	Quantity	Reference	Part	Description
1	1	COAX1	Out Balun	Coax Cable RG316 50-Ohm Length 125mm Shield to Shield
2	1	COAX2	NC	Coax Cable RG178 Length 125mm Shield to Shield Wrapped in
3	1	CS1	CSRF0408R3	Circuito stampato PA
4	1	CS2	CSSU0419R2	Circuito stampato Balun RG316-50
5	3	C8, C51, C92	47p	Cond. SMD 0805 COG
6	11	C9, C14, C22, C25, C28, C57, C58, C72, C77, C82, C91	10n	SMD 0805 MLCC X7R
7	5	C11, C23, C64, C73, C80	100n	SMD 0805 MLCC X7R
8	13	C15, C17, C18, C47, C49, C62, C71, C93, C109, C116, C118, C123, C124	NC	Cond. SMD 0805 COG
9	16	C16, C19, C21, C29, C30, C31, C32, C39, C40, C86, C110, C111, C112, C113, C114, C115	1n	Cond. SMD 0805 COG
10	3	C20, C53, C54	NC	Capacitor SMD 1210 MLCC X7R 100V
11	9	C24, C33, C34, C35, C55, C63, C68, C99, C101	4n7	SMD 0805 MLCC X7R
12	4	C26, C59, C65, C76	NC	Cond. SMD 1212 HQ
13	2	C27, C45	220n 100V	Capacitor SMD 1210 MLCC X7R 100V
14	2	C36, C44	47u 63V	Cond. Elett. SMD d. 8mm
15	3	C37, C61, C69	470p	Cond. SMD 1212 HQ
16	2	C38, C106	27p	Cond. SMD 0805 COG
17	2	C41, C103	120p	Cond. SMD 0805 COG
18	2	C42, C107	39p	Cond. SMD 1212 HQ
19	2	C43, C108	100p	Cond. SMD 1212 HQ
20	3	C46, C87, C104	470p	Cond. SMD 0805 COG
21	2	C48, C105	82p	Cond. SMD 0805 COG
22	4	C50, C81, C89, C117	68p	Cond. SMD 0805 COG
23	2	C52, C100	100p	Cond. SMD 0805 COG
24	2	C56, C96	2n2	SMD 0805 MLCC X7R
25	1	C60	7/50p	Adj. Cap 7 / 50pF
26	5	C66, C67, C83, C84, C85	22p	Cond. SMD 1212 HQ
27	2	C70, C79	1p	Cond. SMD 1212 HQ
28	1	C74	5p6	Cond. SMD 1212 HQ
29	1	C75	6p8	Cond. SMD 1212 HQ
30	1	C78	2p2	Cond. SMD 1212 HQ
31	2	C88, C94	56p	Cond. SMD 0805 COG
32	1	C90	2p7	Cond. SMD 0805 COG
33	1	C95	39p	Cond. SMD 0805 COG
34	1	C97	5p6	Cond. SMD 0805 COG
35	1	C98	NC	Cond. SMD 0805 COG
36	1	C102	12p	Cond. SMD 0805 COG
37	1	C119	15p	Cond. SMD 1212 HQ
38	1	C120	22p	Cond. SMD 0805 COG
39	1	C122	22u 16V	Capacitor SMD 1210 MLCC X7R 16V
40	1	DCPLR1	DIR_CPLR	Toroidal Directional Coupler
41	1	D2	15V	MINIMELF SMD Zener Diode
42	1	D3	BAS32	Minimelf Diode
43	1	D4	9V1	MINIMELF SMD Zener Diode
44	2	D5, D6	BAS70	Hot Carrier Schottky Diode
45	1	D7	BA779-G	SOT23 Pin Diode
46	3	FID1, FID2, FID3	FID	Fiducial CS
47	11	FIX1, FIX2, FIX3, FIX4, FIX5, FIX6, FIX7, FIX8, FIX9, FIX10, FIX11	FIX35	
48	1	JP1	WE 610 008 211 21	2.54mm DUAL SMT PIN HEADER (4+4)
49	1	JP3	Bias Sel	
50	1	JP4	Hyst Sel	
51	1	JP5	RF Level	
52	4	L2, L4, L10, L22	WE 742792022	Ferrite Bead
53	2	L3, L9	WE 7427512	Ferrite Bead
54	6	L5, L7, L18, L21, L25, L28	47n	Induttanza SMD HQ 2012 Wirewound (0805)
55	2	L6, L27	33n	Induttanza SMD HQ 2012 Wirewound (0805)
56	2	L8, L26	35n	4 spire filo 1mm R.Arg avvolte su D.3.5 lungh 9 mm
57	1	L11	40n	4 spire filo 1mm R.Arg avvolte su D.4 lungh 5.5 mm
58	1	L12	NC	Induttanza cilindrica
59	1	L13	250n	15 spire filo 0.8mm R. Smaltato avvolte su D.3.5 in modo co
60	1	L14	470n	Induttanza SMD HQ 2012 Wirewound (0805)
61	1	L15	NC	Induttanza SMD HQ 2012 (0805)

Item	Quantity	Reference	Part	Description
62	2	L16, L19	90n	5 Spire Filo D. 1mm Rame Arg. avvolte su D. 6.5 lungh. 11 mm
63	1	L17	70n	4 Spire Filo D. 1mm Rame Arg. avvolte su D. 6.5 lungh. 6 mm
64	1	L20	100n	Induttanza SMD HQ 2012 Wirewound (0805)
65	2	L23, L24	22n	Coilcraft Square Air Core Inductor 0908SQ-22N
66	1	L30	47uH	PWR Ind WE 74404042470
67	2	MOS1, MOS2	MRFE6VS25NR1	Single LDMOS
68	11	PD1, PD2, PD3, PD4, PD5, PD6, PD7, PD8, PD9, PD10, PD11	PAD	Pad for connection
69	1	Q1	NC	Trans. NPN SOT23
70	1	Q2	BC847B	Trans. NPN SOT23
71	1	Q3	BSS123L	SOT23 NMOS
72	1	Q4	SI7469DP	Power PMOS
73	3	Q5, Q7, Q8	BC857B	Trans. PNP SOT23
74	3	Q6, Q9, Q10	BFU590G	Trans. NPN SOT223
75	2	RV1, RV2	10k	Trimmer SMD
76	1	R1	18k	Res. SMD 0805
77	1	R3	5k6	Res. SMD 0805
78	1	R4	2k2	Res. SMD 0805
79	10	R5, R20, R24, R37, R38, R52, R56, R79, R87, R91	1k	Res. SMD 0805
80	1	R7	8k2	Res. SMD 0805
81	5	R8, R23, R36, R69, R78	100R	Res. SMD 0805
82	4	R11, R18, R55, R71	470R	Res. SMD 0805
83	7	R12, R16, R19, R30, R33, R34, R35	10k	Res. SMD 0805
84	4	R13, R17, R21, R72	NC	Res. SMD 0805
85	1	R14	2k	Res. SMD 0805
86	2	R15, R54	4k7	Res. SMD 0805
87	2	R22, R64	560R	Res. SMD 0805
88	1	R25	27k	Res. SMD 0805
89	1	R26	10k	Res. NTC SMD 0805
90	6	R27, R39, R50, R62, R65, R82	680R	Res. SMD 0805
91	1	R28	4k7	Res. SMD 2512 1%
92	3	R29, R51, R68	4R7	Res. SMD 1206
93	3	R31, R58, R70	22R	Res. SMD 0805
94	2	R32, R74	3k9	Res. SMD 0805
95	2	R40, R44	22R	Res. SMD 2512 1%
96	3	R41, R73, R85	1R	Res. SMD 0805
97	3	R42, R49, R81	47R	Res. SMD 1206
98	3	R43, R60, R80	NC	Res. SMD 1206
99	1	R45	0R	Res. SMD 0805
100	2	R46, R86	4R7	Res. SMD 0805
101	3	R47, R48, R59	47R	Res. SMD 0805
102	2	R53, R57	51R	Res. SMD 2512 1%
103	2	R61, R66	100k	Res. SMD 0805
104	1	R63	330R	Res. SMD 0805
105	1	R67	47R	Res. SMD 2512 1%
106	1	R75	22R	Res. SMD 1206
107	3	R76, R97, R99	10R	Res. SMD 0805
108	1	R77	56R	Res. SMD 0805
109	2	R83, R84	100R	Res. SMD 1206
110	1	R88	0R	Res. SMD 1206
111	1	R92	3k3	Res. SMD 0805
112	1	R93	3R9	Res. SMD 0805
113	1	R94	10R	Res. SMD 1206
114	1	R95	2k7	Res. SMD 0805
115	1	R96	120R	Res. SMD 0805
116	1	R98	NC	Res. SMD 2512 1%
117	9	TL1, TL2, TL3, TL4, TL5, TL6, TL7, TL8, TL9	TLINE_5	Linea strip CS
118	1	TR1	TCM2-33X+	Minicircuits SMT RF Balun
119	1	U2	TLV431	Low Volt. Adj. Shunt Reg 1.24Vref
120	1	U3	LMC6482	Rail to Rail Dual Op. SMD SO8
121	1	W7	NC	

SLPC0463R05V01

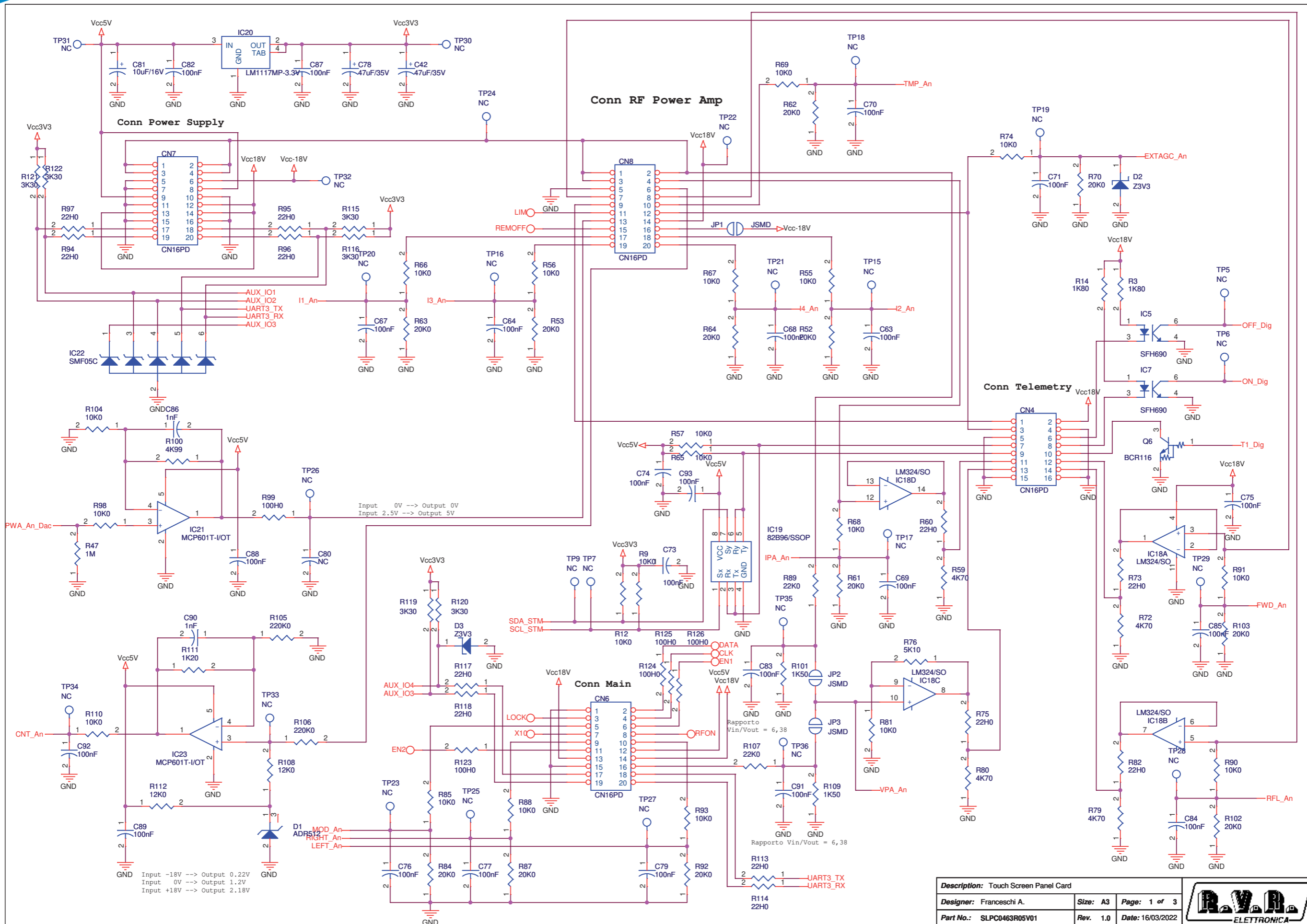

Description: Touch Screen Panel Card		
Designer: Franceschi A.	Size: A3	Page: 1 of 3
Part No.: SLPC0463R05V01	Rev. 1.0	Date: 16/03/2022



SLPC0463R05V01

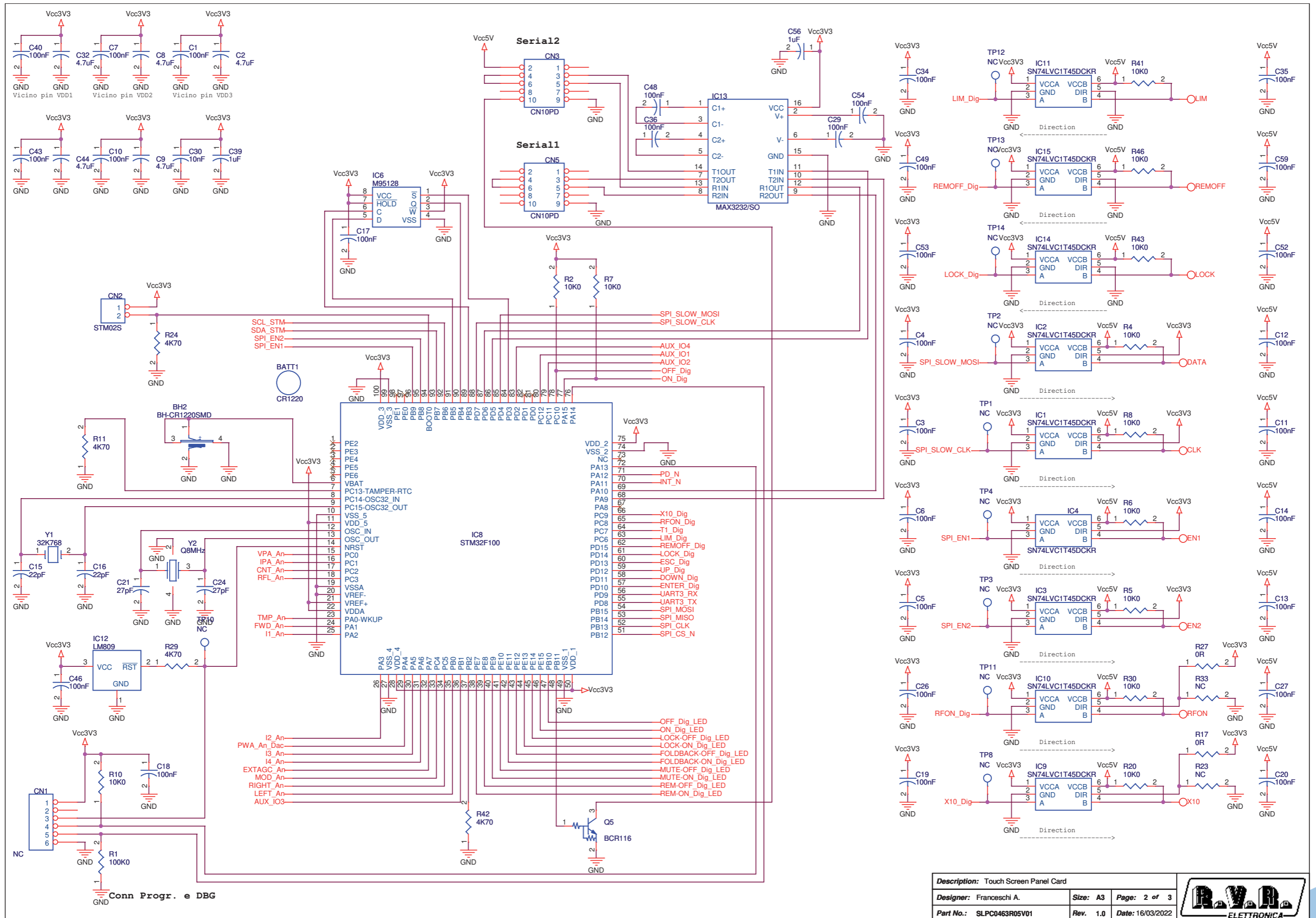

Description: Touch Screen Panel Card			
Designer: Franceschi A.	Size: A3	Page: 2 of 3	
Part No.: SLPC0463R05V01	Rev.: 1.0	Date: 16/03/2022	

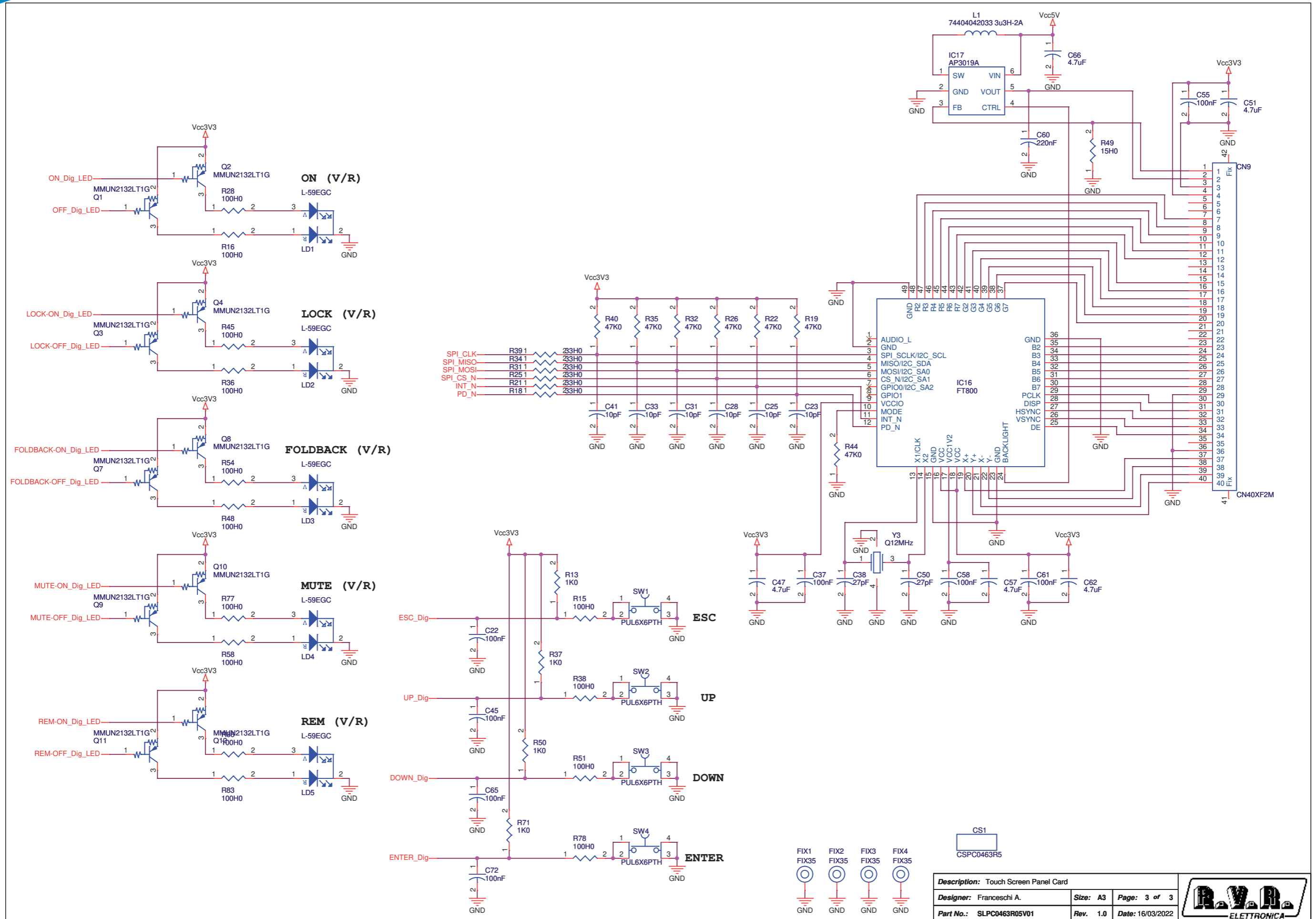

Description: Touch Screen Panel Card		
Designer: Franceschi A.	Size: A3	Page: 3 of 3
Part No.: SLPC0463R05V01	Rev.: 1.0	Date: 16/03/2022



SLPC0463R05V01

Touch Screen Panel Card Revised: 16/03/2022
 SLPC0463R05V01 Revision: 1.0
 Franceschi A.

Item	Quantity	Reference	Part	Description
1	1	BATT1	CR1220	CR1220 Lithium Battery
2	1	BH2	BH-CR1220SMD	CR1220 SMD Battery holder
3	1	CN1	NC	6 way PTH Micromatch connector
4	1	CN2	STM02S	Male strip 2 pin
5	2	CN3, CN5	CN10PD	10 way pcb conn.
6	1	CN4	CN16PD	16 way pcb conn.
7	3	CN6, CN7, CN8	CN16PD	16 way pcb conn.
8	1	CN9	CN40XF2M	40 way ZIF conn. pitch 0,5mm
9	1	CS1	CSPC0463R4	Printed Circuit board
10	61	C1, C3, C4, C5, C6, C7, C10, C11, C12, C13, C14, C17, C18, C19, C20, C22, C26, C27, C29, C34, C35, C36, C37, C40, C43, C45, C46, C48, C49, C52, C53, C54, C55, C58, C59, C61, C63, C64, C65, C67, C68, C69, C70, C71, C72, C73, C74, C75, C76, C77, C79, C82, C83, C84, C85, C87, C88, C89, C91, C92, C93	100nF	0603 SMD capacitor
11	10	C2, C8, C9, C32, C44, C47, C51, C57, C62, C66	4.7uF	0603 SMD capacitor
12	2	C15, C16	22pF	0603 SMD capacitor
13	4	C21, C24, C38, C50	27pF	0603 SMD capacitor
14	6	C23, C25, C28, C31, C33, C41	10pF	0603 SMD capacitor
15	1	C30	10nF	0603 SMD capacitor
16	2	C39, C56	1uF	0603 SMD capacitor
17	2	C42, C78	47uF/35V	SMD electr. cap. 6.3mm
18	1	C60	220nF	0603 SMD capacitor
19	1	C80	NC	0603 SMD capacitor
20	1	C81	10uF/16V	SMD electr. cap. 4mm
21	2	C86, C90	1nF	0603 SMD capacitor
22	1	D1	ADR512	SMD SOT23 precision Zener
23	2	D2, D3	Z3V3	SOD123F Zener Diode
24	4	FIX1, FIX2, FIX3, FIX4	FIX35	3.5mm Fixing hole
25	9	IC1, IC2, IC3, IC4, IC9, IC10, IC11, IC14, IC15	SN74LVC1T45DCKR	Bidirect. level translator
26	2	IC5, IC7	SFH690	Optocoupler SMD SO6
27	1	IC6	M95128	SMD Serial EEPROM
28	1	IC8	STM32F100	STM32F100 Microcontroller
29	1	IC12	LM809-2.93	uC supervisor
30	1	IC13	MAX3232/SO	SO16 RS232 driver
31	1	IC16	FT800	Display controller
32	1	IC17	AP3019A	Switching LED driver
33	1	IC18	LM324/SO	Quad Op. SMD SO14
34	1	IC19	82B96/SSOP	SMD IIC Bus driver
35	1	IC20	LM1117MP-3.3V	Voltage reg. SMD SOT223
36	2	IC21, IC23	MCP601T-I/OT	Single Op Amp SOT23-5
37	1	IC22	SMF05C	TVS Diode array
38	3	JP1, JP2, JP3	J5MD	2 pad SMD jumper
39	5	LD1, LD2, LD3, LD4, LD5	L-59EGC	Two-color led common Cathode 5mm
40	1	L1	74404042033 3u3H-2A	WE LQ540 series inductor
41	10	Q1, Q2, Q3, Q4, Q7, Q8, Q9, Q10, Q11, Q12	MMUN2132LT1G	Digital PNP trans. SOT23
42	2	Q5, Q6	BCR116	Digital NPN trans. SOT23
43	1	R1	100K0	0603 SMD res.
44	32	R2, R4, R5, R6, R7, R8, R9, R10, R12, R20, R30, R41, R43, R46, R55, R56, R57, R65, R66, R67, R68, R69, R74, R81, R85, R88, R90, R91, R93, R98, R104, R110	10K0	0603 SMD res.
45	2	R3, R14	1K80	0805 SMD res.
46	8	R11, R24, R29, R42, R59, R72, R79, R80	4K70	0603 SMD res.
47	4	R13, R37, R50, R71	1K0	0603 SMD res.
48	19	R15, R16, R28, R36, R38, R45, R48, R51, R54, R58, R77, R78, R83, R86, R99, R123, R124, R125, R126	100H0	0603 SMD res.
49	2	R17, R27	0R	0603 SMD res.
50	6	R18, R21, R25, R31, R34, R39	33H0	0603 SMD res.
51	7	R19, R22, R26, R32, R35, R40, R44	47K0	0603 SMD res.
52	2	R23, R33	NC	0603 SMD res.
53	1	R47	1M	0603 SMD res.
54	1	R49	15H0	0603 SMD res.
55	12	R52, R53, R61, R62, R63, R64, R70, R84, R87, R92, R102, R103	20K0	0603 SMD res.
56	12	R60, R73, R75, R82, R94, R95, R96, R97, R113, R114, R117, R118	22H0	0603 SMD res.
57	1	R76	5K10	0603 SMD res.
58	2	R89, R107	22K0	0603 SMD res.
59	1	R100	4K99	0603 SMD res.
60	2	R101, R109	1K50	0603 SMD res.
61	2	R105, R106	220K0	0603 SMD res.
62	2	R108, R112	12K0	0603 SMD res.
63	1	R111	1K20	0603 SMD res.
64	6	R115, R116, R119, R120, R121, R122	3K30	0603 SMD res.
65	4	SW1, SW2, SW3, SW4	PUL6X6PTH	PCB PTH pushbutton
66	36	TP1, TP2, TP3, TP4, TP5, TP6, TP7, TP8, TP9, TP10, TP11, TP12, TP13, TP14, TP15, TP16, TP17, TP18, TP19, TP20, TP21, TP22, TP23, TP24, TP25, TP26, TP27, TP28, TP29, TP30, TP31, TP32, TP33, TP34, TP35, TP36	NC	Test point
67	1	Y1	32K768	SMD Crystal 3.2x1.5 mm
68	1	Y2	Q8MHz	SMD Crystal NX5032SA
69	1	Y3	Q12MHz	SMD Crystal 2x2.5 mm

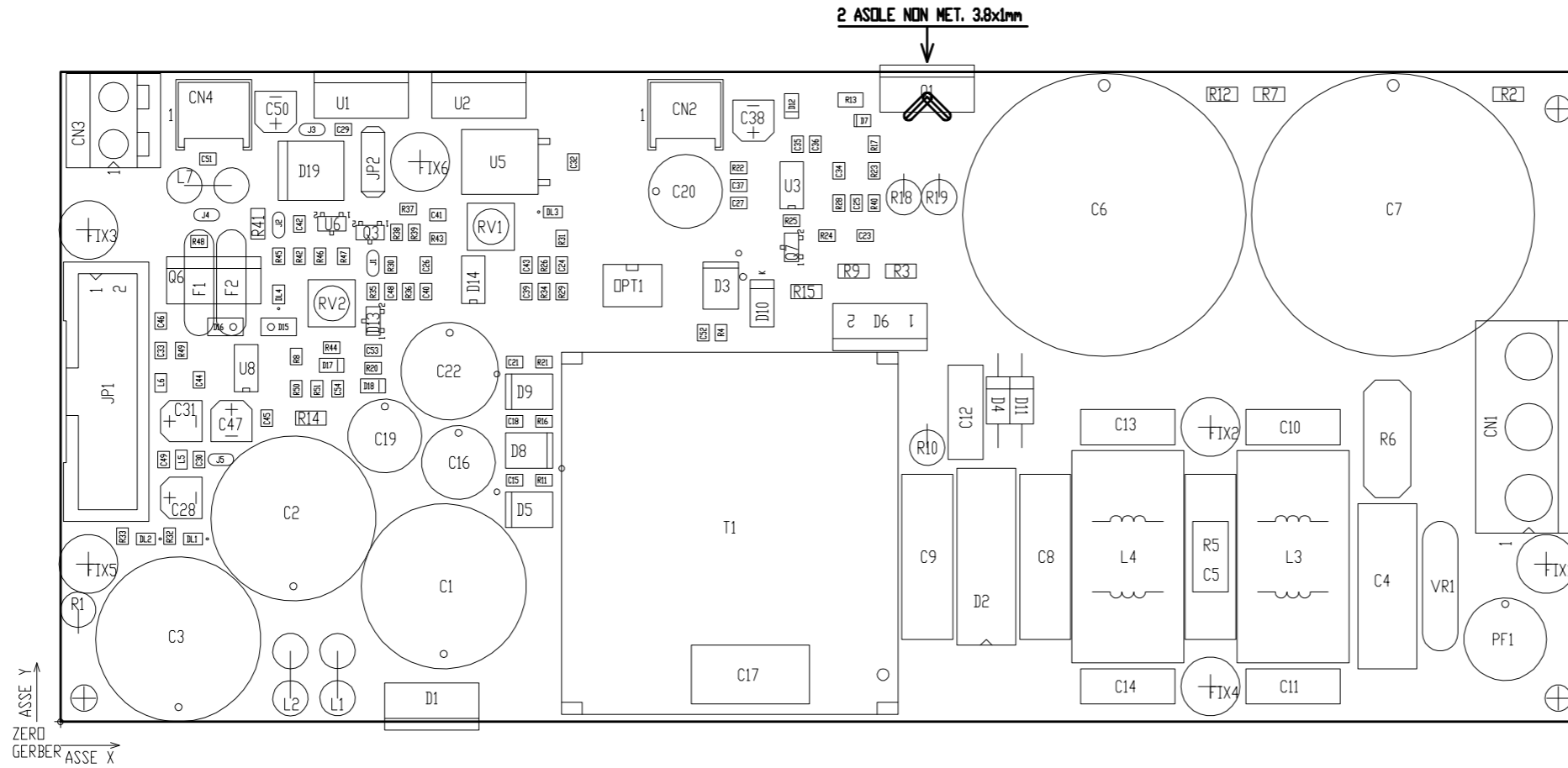

RILASCIO: 29/12/2015

REV:

DIM.SCHEDA: VEDI PROFILO
TRATT.: STANDARD COSTRUTTORE

MAT.: FR4-74 1.6mm Cu 35um 2 LAYER
VISTA POSITIVA

DIS. S.POL.
CTR. L.G.
LATO PIANO DI MONTAGGIO
VISTA LATO COMPONENTI

DENOMINAZIONE
FLY 100

CODICE
CSPS43-120W0200

TEKNIGHT

SCALA 1:1

KPSL4303V01B

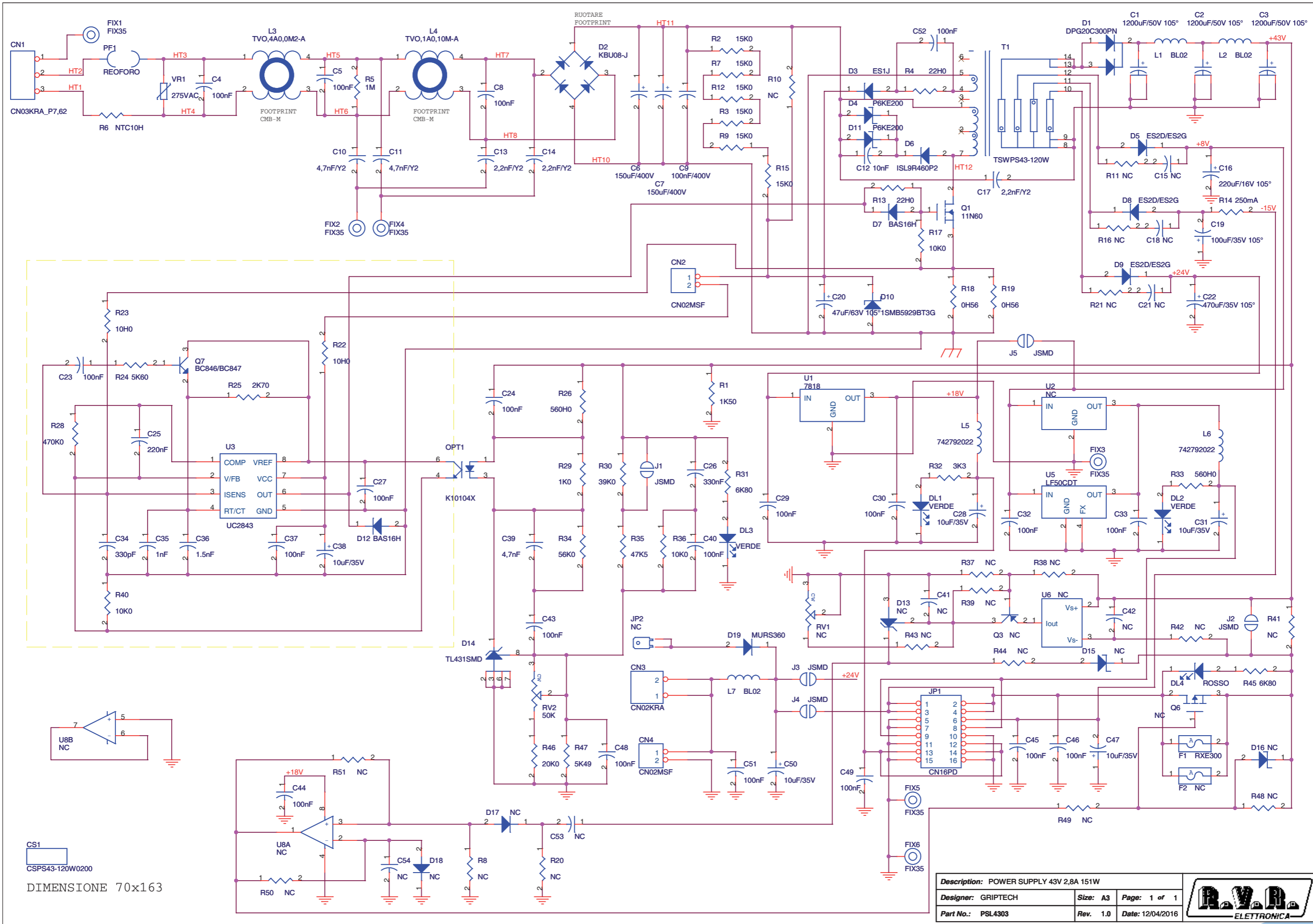

DIMENSIONE 70x163

Description: POWER SUPPLY 43V 2,8A 151W		
Designer: GRIPTECH	Size: A3	Page: 1 of 1
Part No.: PSL4303	Rev.: 1.0	Date: 12/04/2016



KPSL4303V01B

POWER SUPPLY 43V 2,8A 151W
PSL4303
12/04/2016 REV.1.0

Item	Quantity	Reference	Part	(description)
1	1	CN1	CN03KRA P7,62	Conn. tipo KRA a 3 poli
2	2	CN2, CN4	CN02MSF	Connettore 2 poli Lumberg MSF p 2.5mm
3	1	CN3	CN02KRA	Conn. tipo KRA a 2 poli
4	1	CS1	CSPS43-120W0200	Circuito stampato
5	3	C1, C2, C3	1200uF/50V 105°	Cond. Elettr. Dia 16 105°C
6	3	C4, C5, C8	100nF	Cond. Poliestere p 15mm
7	2	C7, C6	150uF/400V	Cond. Elettr. Dia 30 P10
8	1	C9	100nF/400V	Cond. Poliestere p 15mm
9	2	C11, C10	4,7nF/Y2	Cond. ceramico p 7mm Y2
10	1	C12	10nF	Cond. ceramico p 7mm Y2
11	3	C13, C14, C17	2,2nF/Y2	Cond. ceramico p 7mm Y2
12	7	C15, C18, C21, C41, C42, C53, C54	NC	Cond. SMD 0805
13	1	C16	220uF/16V 105°	Cond. Elettr. Dia 8 P3
14	1	C19	100uF/35V 105°	Cond. Elettr. Dia 8 P3
15	1	C20	47uF/63V 105°	Cond. Elettr. Dia 8 P3
16	1	C22	470uF/35V 105°	Cond. Elettr. Dia 10 P5.08
17	17	C23, C24, C27, C29, C30, C32, C33, C37, C40, C43, C44, C45, C46, C48, C49, C51, C52	100nF	Cond. SMD 0805
18	1	C25	220nF	Cond. SMD 0805
19	1	C26	330nF	Cond. SMD 0805
20	5	C28, C31, C38, C50, C47	10uF/35V	Cond. Elett. SMD d. 4mm
21	1	C34	330pF	Cond. SMD 0805
22	1	C35	1nF	Cond. SMD 0805
23	1	C36	1.5nF	Cond. SMD 0805
24	1	C39	4,7nF	Cond. SMD 0805
25	3	DL1, DL2, DL3	VERDE	LED Verde SMD 0805
26	1	DL4	ROSSO	LED Verde SMD 0805
27	1	D1	DPG20C300PN	Doppio diodo TO220
28	1	D2	KBU08-J	Ponte diodi KBL/KBU
29	1	D3	ES1J	Diodo SMD cont. SMA
30	2	D11, D4	P6KE200	1W Zener Diode
31	3	D5, D8, D9	ES2D/ES2G	Diodo SMD cont. SMB
32	1	D6	ISL9R460P2	Diodo TO220
33	1	D12	BAS16H	Diodo SMD cont. SOD123F
34	1	D10	1SMB5929BT3G	Diodo SMD cont. SMB
35	6	JP2, F2, U6, Q6, U8, D13	NC	
36	1	D14	TL431SMD	SO8 Reference
37	2	D15, D16	NC	MINIMELF SMD Zener Diode
38	2	D17, D18	NC	Diodo SMD cont. SOD123F
39	1	D19	MURS360	Diodo SMD cont. SMC
40	6	FIX1, FIX2, FIX3, FIX4, FIX5, FIX6	FIX35	Foro fissaggio 3.5mm
41	1	F1	RXE300	Fus autoripristinante
42	1	JP1	CN16PD	Conn.M.C.S.Dritto 16P alette.
43	1	J1	J5MD	Pad SMD a saldare
44	4	J2, J3, J4, J5	J5MD	Pad SMD a saldare
45	3	L1, L2, L7	BL02	Induttanza cilindrica
46	1	L3	TVO.4A0.0M2-A	Ind. toroidale modo comune
47	1	L4	TVO.1A0.10M-A	Ind. toroidale modo comune
48	2	L6, L5	742792022	Induttanza SMD 2012 (0805)
49	1	OPT1	K10104X	Optoisolatore SMD SO6
50	1	PF1	REOFORO	Fusibile Bussmann LET
51	1	Q1	11N60	Trans. FET N TO220
52	1	Q3	NC	Trans. PNP SOT23
53	1	Q7	BC846/BC847	Trans. NPN SOT23
54	1	RV1	NC	Trimmer SMD
55	1	RV2	50K	Trimmer SMD
56	1	R1	1K50	Res. strato 2W
57	6	R2, R3, R7, R9, R12, R15	15K0	Res. SMD 1206
58	1	R4	22H0	Res. SMD 0805
59	1	R5	1M	Res. SMD 2512 1%
60	1	R6	NTC10H	Res. NTC d.10mm
61	15	R8, R11, R16, R20, R21, R37, R38, R39, R42, R43, R44, R48, R49, R50, R51	NC	Res. SMD 0805
62	1	R10	NC	Res. strato 2W
63	1	R13	22H0	Fus. SMD 1206
64	1	R14	250mA	Res. SMD 1206
65	3	R17, R36, R40	10K0	Res. SMD 0805
66	2	R18, R19	0H56	Res. strato 2W
67	2	R22, R23	10H0	Res. SMD 0805
68	1	R24	5K60	Res. SMD 0805
69	1	R25	2K70	Res. SMD 0805
70	2	R33, R26	560H0	Res. SMD 0805
71	1	R28	470K0	Res. SMD 0805
72	1	R29	1K0	Res. SMD 0805
73	1	R30	39K0	Res. SMD 0805
74	2	R31, R45	6K80	Res. SMD 0805
75	1	R32	3K3	Res. SMD 0805
76	1	R34	56K0	Res. SMD 0805
77	1	R35	47K5	Res. SMD 0805
78	1	R41	NC	Res. SMD 1206
79	1	R46	20K0	Res. SMD 0805
80	1	R47	5K49	Res. SMD 0805
81	1	T1	TSWPS43-120W	Trasformatore
82	1	U1	7818	Stabilizzatore TO220
83	1	U2	NC	Stabilizzatore TO220
84	1	U3	UC2843	Reg. switching

Item	Quantity	Reference	Part	(description)
85	1	U5	LF50CDT	Stabilizzatore SMD DPAK
86	1	VR1	275VAC	Varistor dia. 7mm
87	1	D7	BAS16H	Diodo SMD cont. SOD323

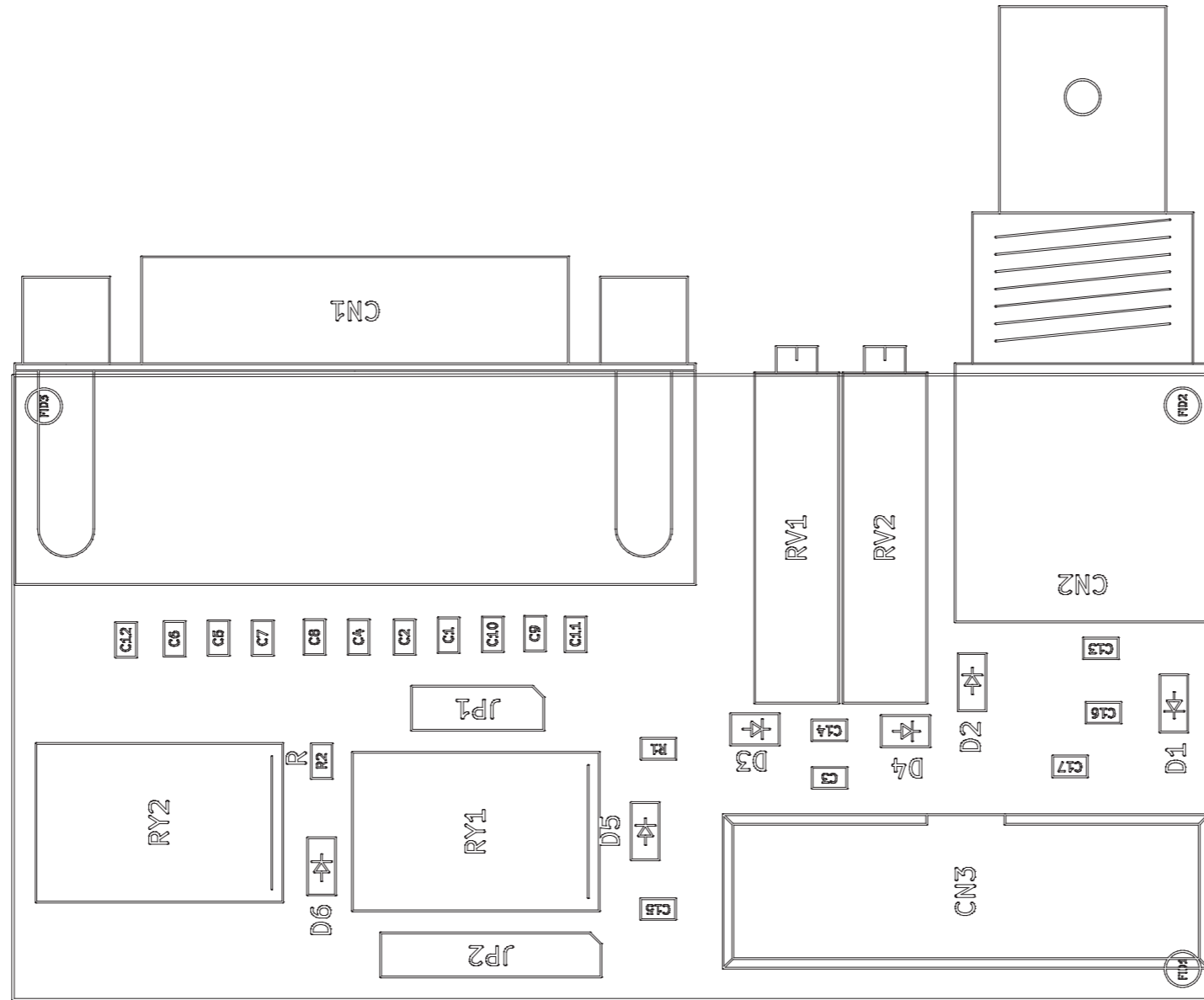

PRODUCT NAME : TEX-TFT

DESIGNER : FRANCESCHI A.

ARCHIVING : 'RVRUT' SERVER, 'RILASCIATI' FOLDER

PART NAME : TELEMETRY CARD

DATE : 22/06/20 | REVISION : 1.0 | SCALE : 2:1 | SIZE : A4 | PAGE : 1 DI 1

PROJECT CODE : <> | DOCUMENT CODE : SLTL0509R01V**

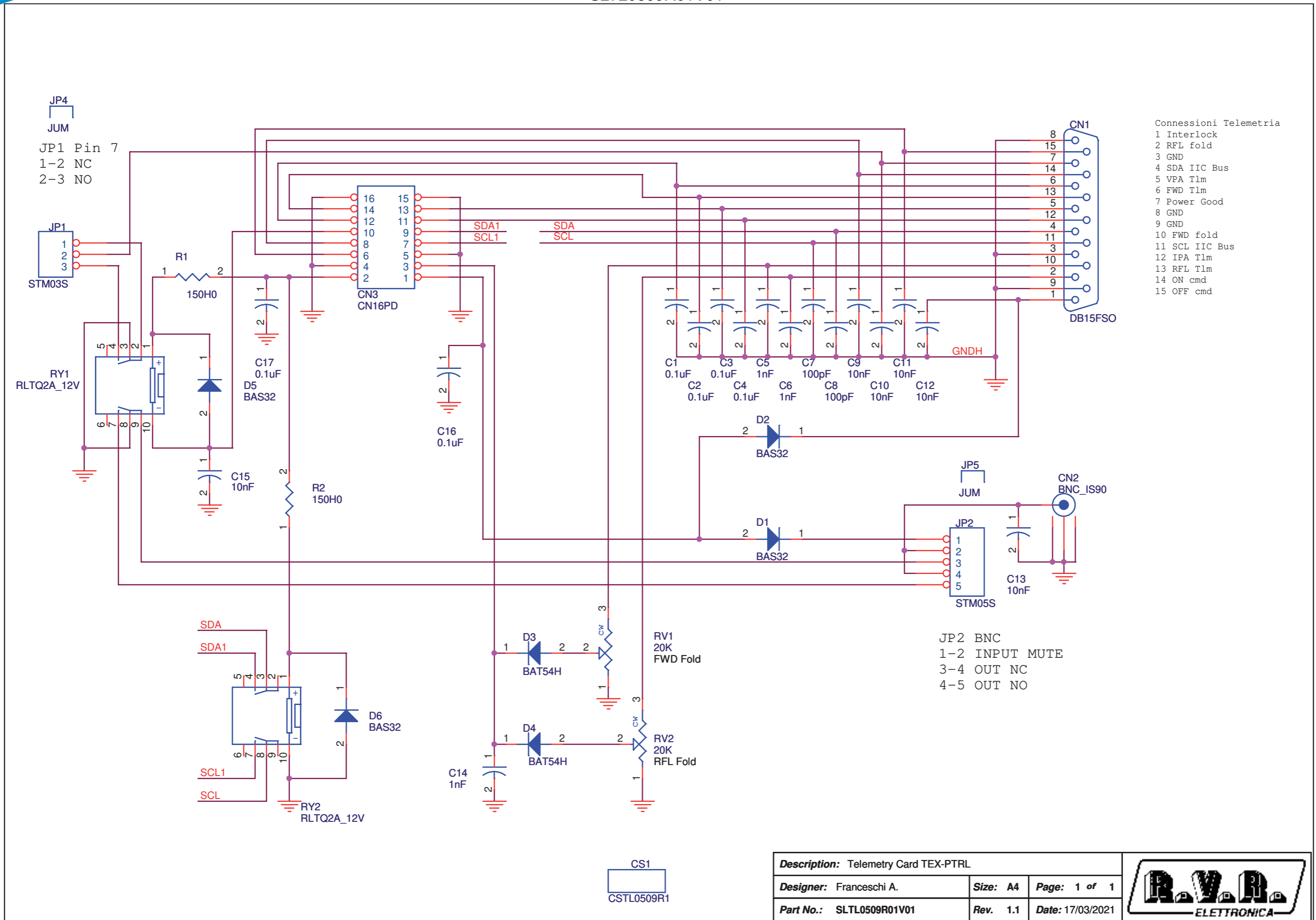

SLTL0509R01V01

Telemetry Card TEX-PTRL Revised: 17/03/2021
 SLTL0509R01V01 Revision: 1.1
 Franceschi A.

Item	Quantity	Reference	Part	Description
1	1	CN1	DB15FSO	DB15 fem. PCB 90° conn.
2	1	CN2	BNC_IS90	Metal BNC conn. 90°
3	1	CN3	CN16PD	16 way pcb conn. with holder
4	1	CS1	CSTL0509R1	Printed Circuit board
5	6	C1, C2, C3, C4, C16, C17	0.1uF	0805 SMD capacitor
6	3	C5, C6, C14	1nF	0805 SMD capacitor
7	2	C7, C8	100pF	0805 SMD capacitor
8	6	C9, C10, C11, C12, C13, C15	10nF	0805 SMD capacitor
9	4	D1, D2, D5, D6	BAS32	MINIMELF SMD Diode
10	2	D3, D4	BAT54H	SOD123F SMD Diode
11	1	JP1	STM03S	Male strip 3 pin
12	1	JP2	STM05S	Male strip 5 pin
13	2	JP4, JP5	JUM	Jumper
14	2	RV1, RV2	20K	Trimmer Rg H 3006
15	2	RY1, RY2	RLTQ2A_12V	TQ2 relay
16	2	R1, R2	150H0	0805 SMD res.

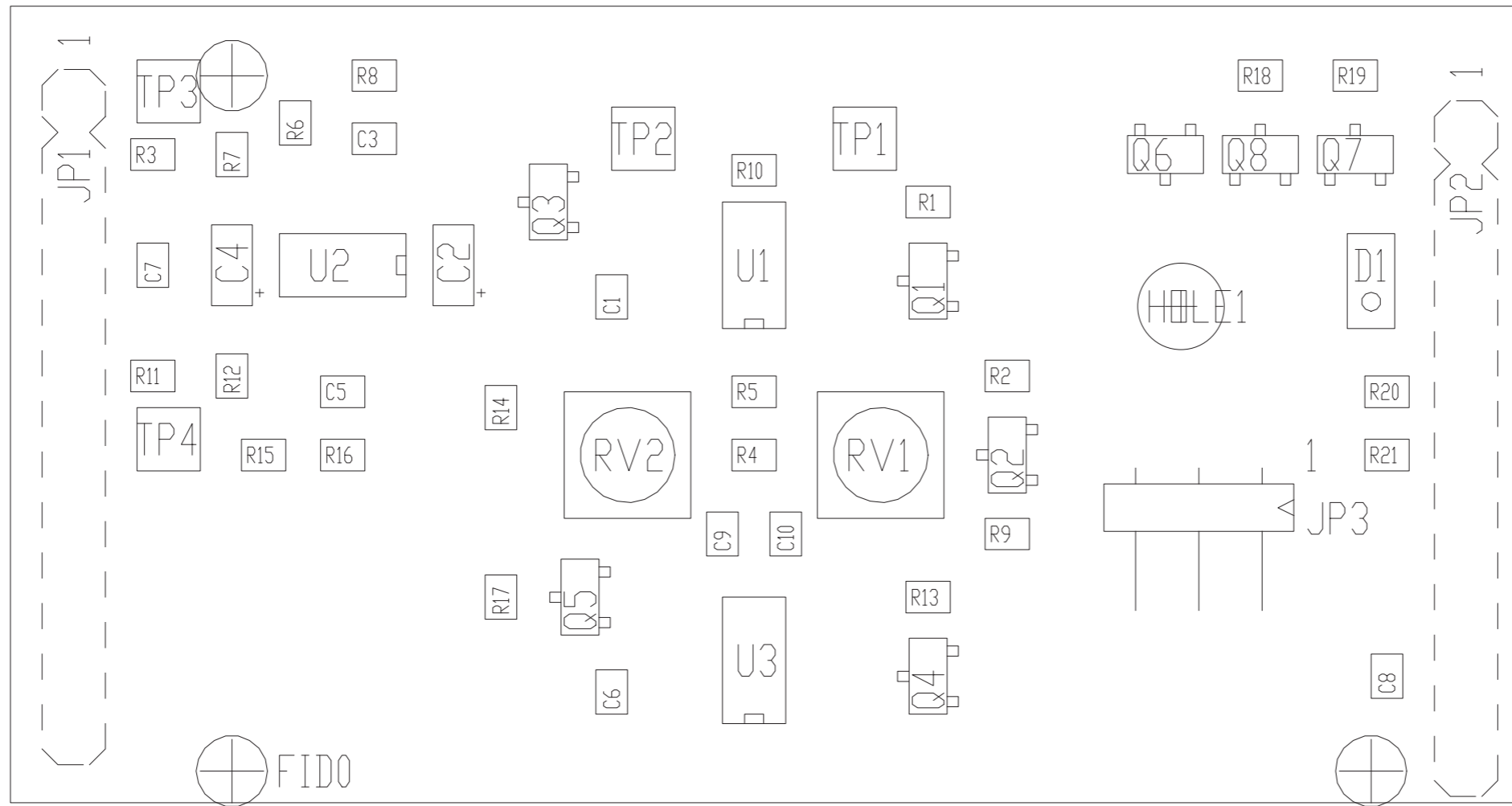

PRODUCT NAME : TEX-TFT	PART NAME : L/R Clipper for Stereo Coder
DESIGNER : FRANCESCHI A.	DATE : 13/01/20
ARCHIVING : "RVRUT" SERVER, "RILASCIATI" FOLDER	REVISION : 1.0
	SCALE : 1:1
	SIZE : A4
	PAGE : 1
	DI : 1
	DOCUMENT CODE : SLCS0391R01V**
	PROJECT CODE : 252

SLCS0391R01V02

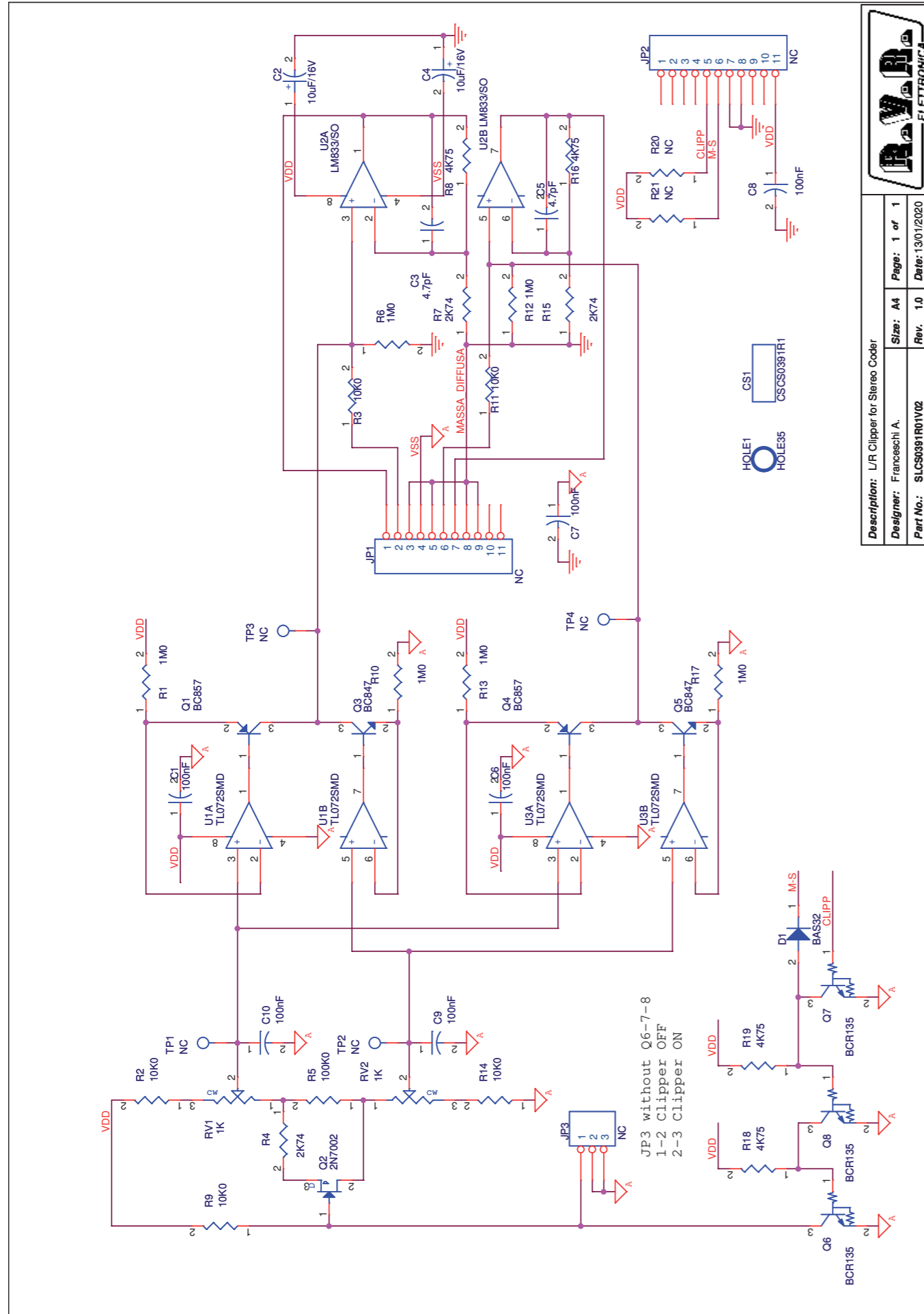

Description: L/R Clipper for Stereo Coder
Designer: Franceschi A.
Part No.: SLCS0391R01V02
Size: A4
Page: 1 of 1
Rev.: 1.0
Date: 13/01/2020

L/R Clipper for Stereo Coder Revised: Monday, Jan 13, 2020
 SLCS0391R01V02 Revision: 1.0
 Franceschi A.

Item	Quantity	Reference	Part	Description
1	1	CS1	CSCS0391R1	Circuito stampato
2	6	C1,C6,C7,C8,C9,C10	100nF	Cond. SMD 0805
3	2	C2,C4	10uF/16V	Cond. Elett. SMD tant. size A
4	2	C3,C5	4.7pF	Cond. SMD 0805
5	1	D1	BAS32	MINIMELF SMD Diode
6	1	HOLE1	HOLE35	Foro da 3.5mm
7	2	JP1,JP2	NC	Strip maschio 11 pin
8	1	JP3	NC	Strip maschio 3 pin a 90°
9	2	Q1,Q4	BC857	Trans. PNP SOT23
10	1	Q2	2N7002	Trans. FET SOT23
11	2	Q3,Q5	BC847	Trans. NPN SOT23
12	3	Q6,Q7,Q8	BCR135	Trans./Res. NPN SOT23
13	2	RV1,RV2	1K	Trimmer SMD
14	6	R1,R6,R10,R12,R13,R17	1M0	Res. SMD 0805
15	5	R2,R3,R9,R11,R14	10K0	Res. SMD 0805
16	3	R4,R7,R15	2K74	Res. SMD 0805
17	1	R5	100K0	Res. SMD 0805
18	4	R8,R16,R18,R19	4K75	Res. SMD 0805
19	2	R20,R21	NC	Res. SMD 0805
20	4	TP1,TP2,TP3,TP4	NC	Test point
21	2	U1,U3	TL072SMD	Dual Op. SMD SO8
22	1	U2	LM833/SO	Dual Op. SMD SO8

SLAU0469R01V04

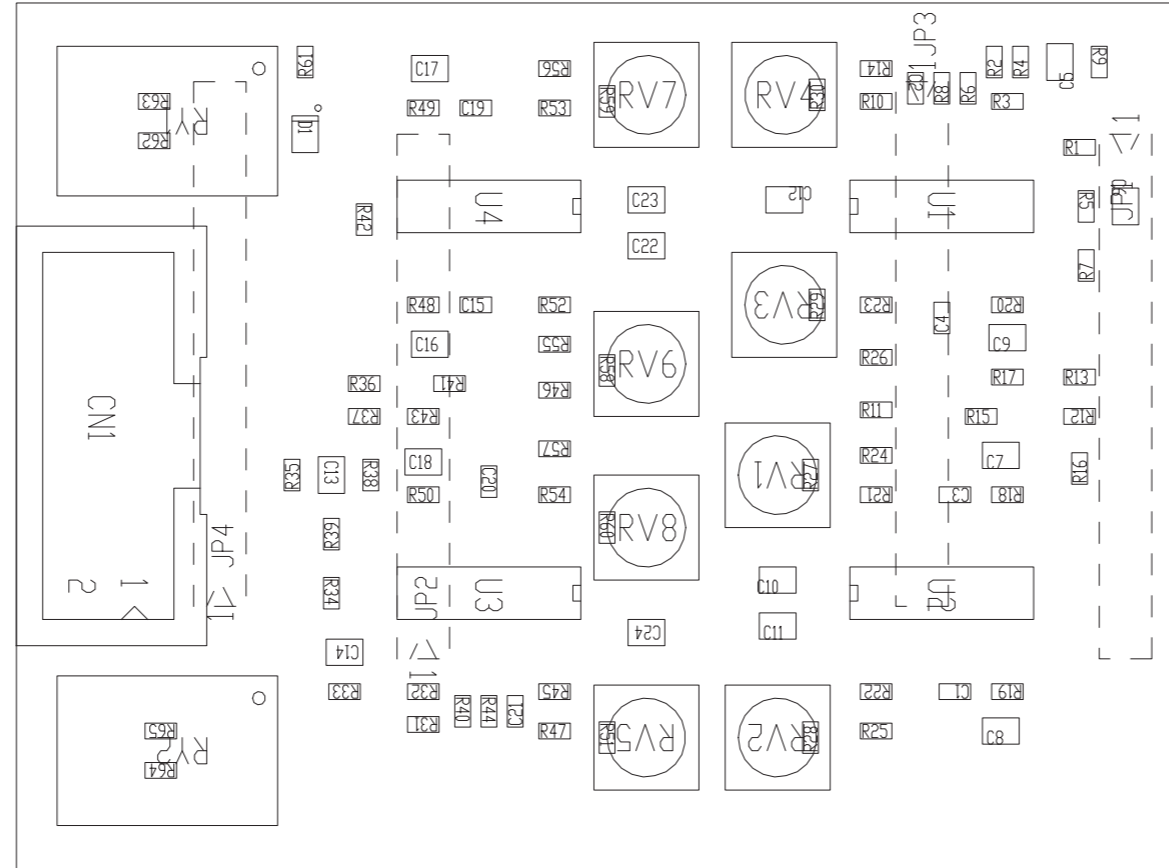

PRODUCT NAME : TEX-LCD

DESIGNER : FRANCESCHI A.

ARCHIVING : "RVRUT" SERVER, "RILASCIATI" FOLDER

PART NAME : AUDID FILTER 15KHZ

DATE : 03/05/17

REVISION : 1.0

SCALE : 2:1

SIZE : A4

PAGE : 1

DI 1

DOCUMENT CODE : SLAU0469R01V**

PROJECT CODE : 057

SLAU0469R01V04

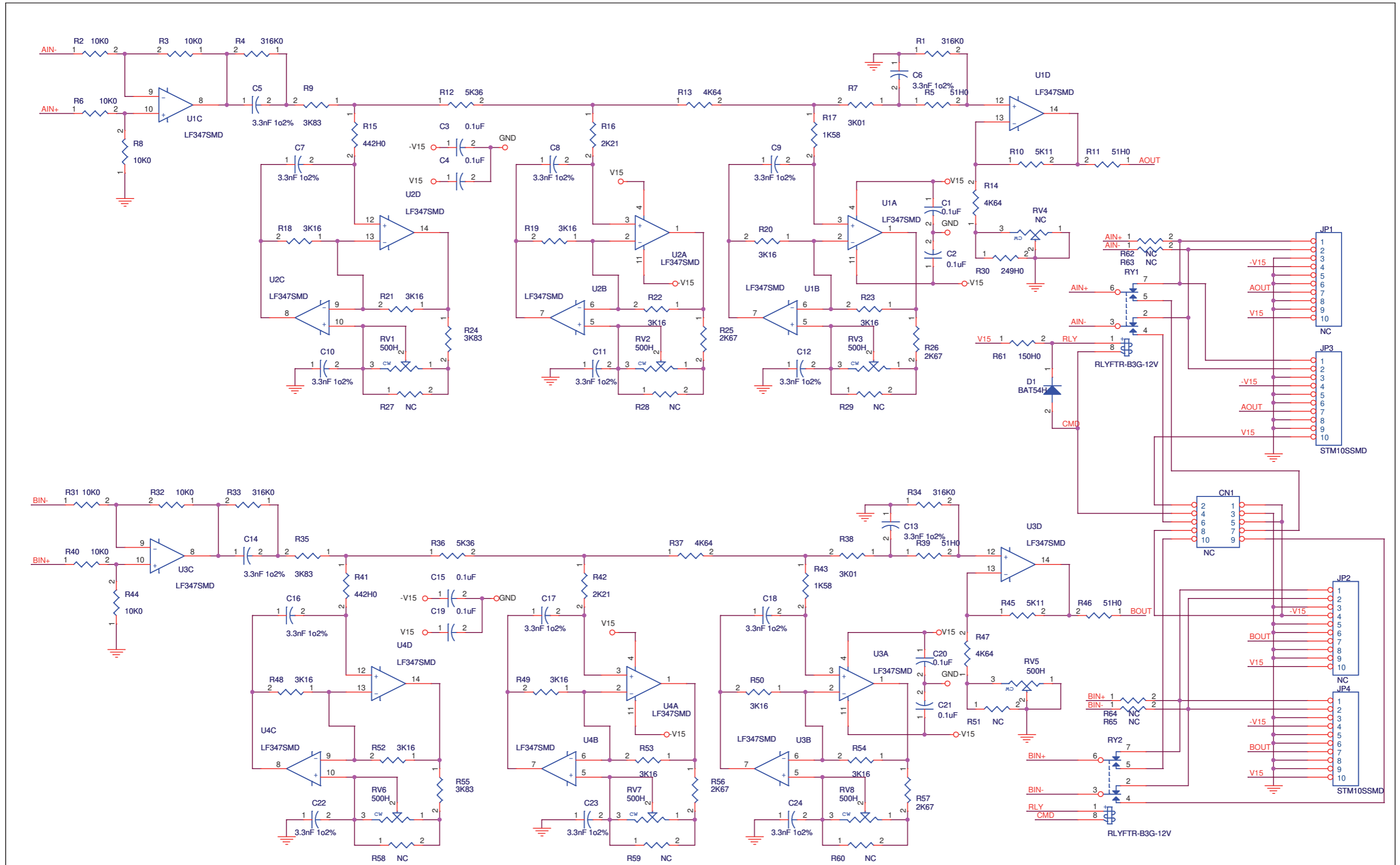

CS1
CSAU0469R1

Description: Audio Filter 15KHz TFT w AES-EBU		
Designer: Franceschi A.	Size: A3	Page: 1 of 1
Part No.: SLAU0469R01V04	Rev. 1.0	Date: 03/04/2018



SLAU0469R01V04

Audio Filter 15Khz TFT w AES-EBU Revised: 03/04/2018
 SLAU0469R01V04 Revision: 1.0
 Franceschi A.

Item	Quantity	Reference	Part	Description
1	1	CN1	NC	Conn. 10 poli Flat cs
2	1	CS1	CSAU0469R1	Circuito stampato
3	8	C1, C2, C3, C4, C15, C19, C20, C21	0.1uF	Cond. SMD 0603
4	16	C5, C6, C7, C8, C9, C10, C11, C12, C13, C14, C16, C17, C18, C22, C23, C24	3.3nF 1o2%	Cond. SMD 0805 COG
5	1	D1	BAT54H	SOD323 SMD Diode
6	2	JP1, JP2	NC	Male strip 10 pin SMD
7	2	JP3, JP4	STM10SSMD	Male strip 10 pin SMD
8	7	RV1, RV2, RV3, RV5, RV6, RV7, RV8	500H	Trimmer SMD V 3314
9	1	RV4	NC	Trimmer SMD V 3314
10	2	RY1, RY2	RLYFTR-B3G-12V	Rele' FTR-B3G
11	4	R1, R4, R33, R34	316K0	Res. SMD 0603
12	8	R2, R3, R6, R8, R31, R32, R40, R44	10K0	Res. SMD 0603
13	4	R5, R11, R39, R46	51H0	Res. SMD 0603
14	2	R7, R38	3K01	Res. SMD 0603
15	4	R9, R24, R35, R55	3K83	Res. SMD 0603
16	2	R10, R45	5K11	Res. SMD 0603
17	2	R12, R36	5K36	Res. SMD 0603
18	4	R13, R14, R37, R47	4K64	Res. SMD 0603
19	2	R15, R41	442H0	Res. SMD 0603
20	2	R16, R42	2K21	Res. SMD 0603
21	2	R17, R43	1K58	Res. SMD 0603
22	12	R18, R19, R20, R21, R22, R23, R48, R49, R50, R52, R53, R54	3K16	Res. SMD 0603
23	4	R25, R26, R56, R57	2K67	Res. SMD 0603
24	11	R27, R28, R29, R51, R58, R59, R60, R62, R63, R64, R65	NC	Res. SMD 0603
25	1	R30	249H0	Res. SMD 0603
26	1	R61	150H0	Res. SMD 0603
27	4	U1, U2, U3, U4	LF347SMD	Quad Op. SMD SO14