



SCML1+1SL (/N1, /N2, /N3 & /N4)

TECHNICAL ANNEX
VOLUME2



Appendix A Piani di montaggio, schemi elettrici, liste componenti / Component layouts, schematics, bills of material

Questa parte del manuale contiene i dettagli tecnici riguardanti la costruzione delle singole schede componenti il SCML1+1SL. L'appendice è composta dalle seguenti sezioni:

This part of the manual contains the technical details about the different boards of the SCML1+1SL. This appendix is composed of the following sections:

Description	SCML1+1SL/V1 RVR Code	SCML1+1SL/V2 RVR Code	SCML1+1SL/V3 RVR Code	SCML1+1SL/V4 RVR Code	Vers. Page
Wiring Diagram	/	/	/	/	1.3 1
Main Board	SL125MA1003	SL125MA1003	SL125MA1003	SL125MA1003	1.1 3
Synoptic Panel Card	SL125PC1001	SL125PC1001	SL125PC1001	SL125PC1001	1.1 7
Panel Card	SLPC0435R01V03	SLPC0435R01V03	SLPC0435R01V03	SLPC0435R01V03	1.1 9
Power Supply	PS.EPS65S24	PS.EPS65S24	PS.EPS65S24	PS.EPS65S24	1.0 10
Power Supply 24V	SLPS0482R02V03	SLPS0482R02V03	SLPS0482R02V03	SLPS0482R02V03	1.1 14
Switching Power Supply 15V	SLPS0520R01V02	SLPS0520R01V02	SLPS0520R01V02	SLPS0520R01V02	1.0 16
DB25 Interface	/	/	SL125IN1001	/	1.1 18
DB9 Interface	SL125IN2001	/	/	SL125IN2001	1.0 20

Document History

Date	Version	Reason	Code	Editor
17/02/2017	2.0	New Graphic & Major Updates	/	J.H. Berti
03/02/2023	2.1	Wiring Diagram, SLPC0435R01V03, PS.EPS65S24, SLPS0482R02V03, SLPS0520R01V02 & SL125IN1001 Updates	/	J.H. Berti

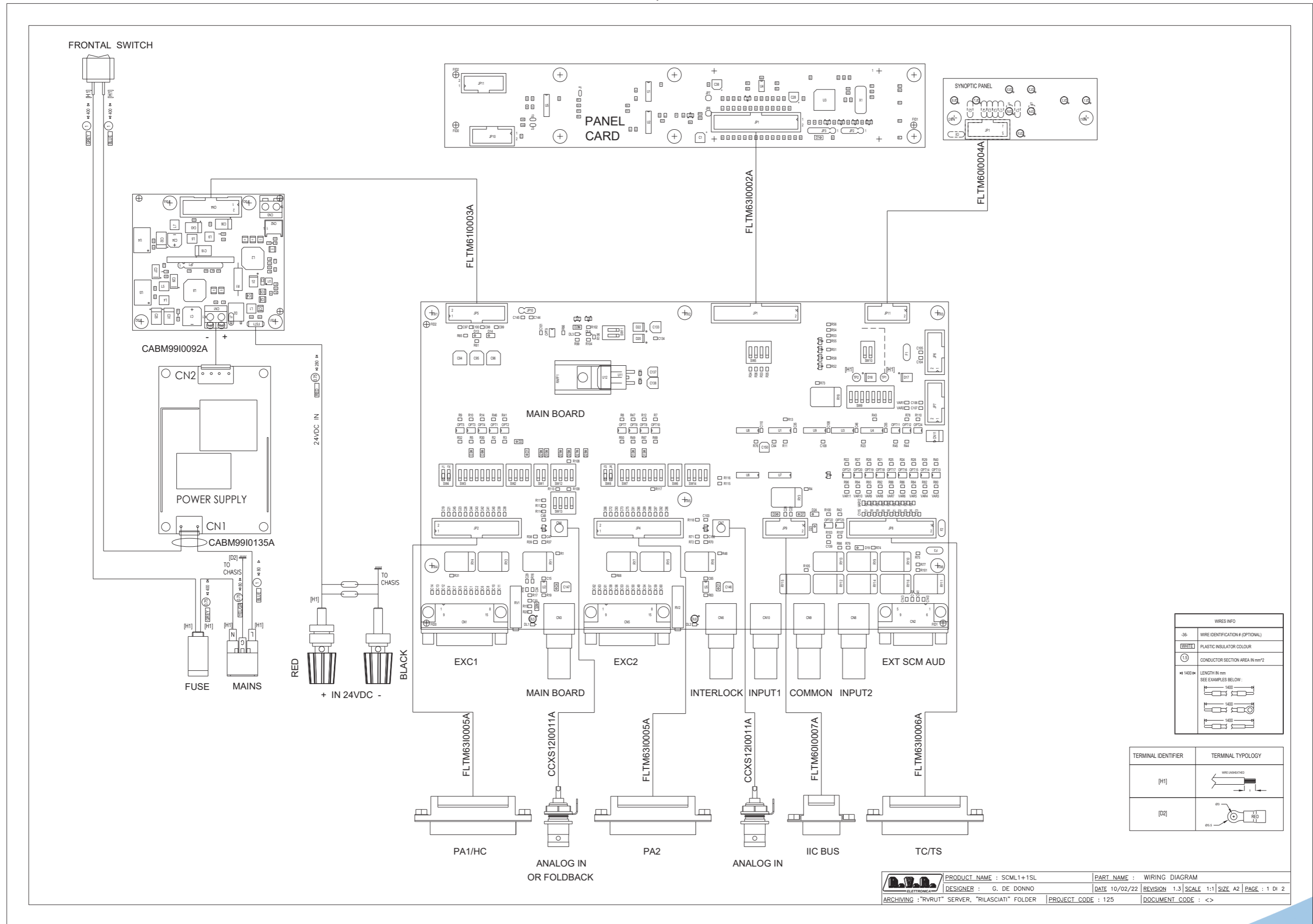

WIRES INFO	
-36	WIRE IDENTIFICATION # (OPTIONAL)
[H1]	PLASTIC INSULATOR COLOUR
[D2]	CONDUCTOR SECTION AREA IN mm ²
1400	LENGTH IN mm SEE EXAMPLES BELOW:

TERMINAL IDENTIFIER	TERMINAL TYPOLOGY
[H1]	WIRE UNHEATED
[D2]	WIRE HEATED

PRODUCT NAME : SCML1+1SL	PART NAME : WIRING DIAGRAM
DESIGNER : G. DE DONNO	DATE 10/02/22 REVISION 1.3 SCALE 1:1 SIZE A2 PAGE : 1 DI 2
ARCHIVING : "RVRT" SERVER, "RILASCIATI" FOLDER	PROJECT_CODE : 125 DOCUMENT_CODE : <>

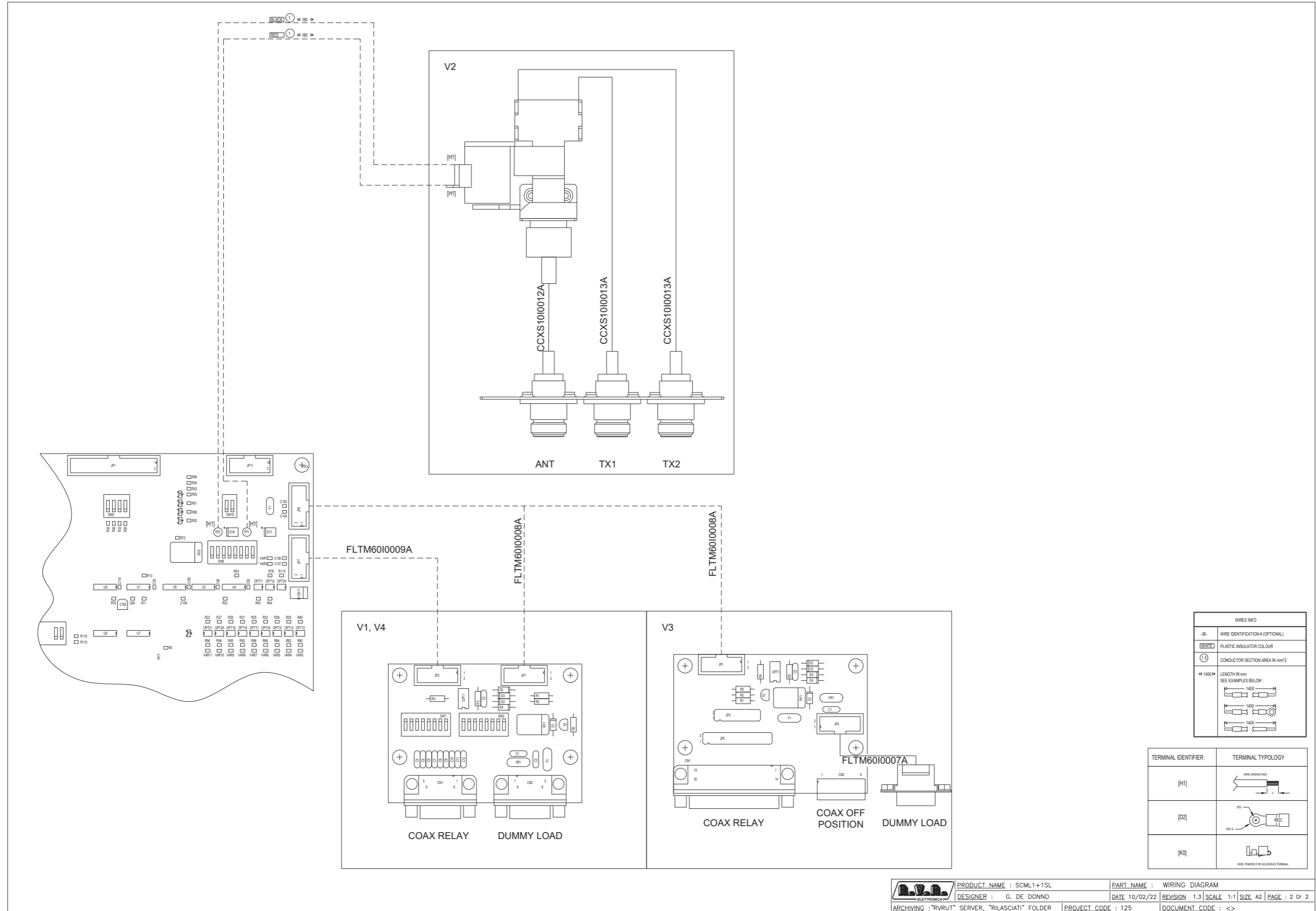

WIRES INFO	
-36-	WIRE IDENTIFICATION # (OPTIONAL)
[WIRE]	PLASTIC INSULATOR COLOUR
⊕	CONDUCTOR SECTION AREA IN mm ²
1400 24	LENGTH IN mm SEE EXAMPLES BELOW:

TERMINAL IDENTIFIER	TERMINAL TYPOLOGY
[H1]	
[D2]	
[K0]	

	PRODUCT NAME : SCML1+1SL	PART NAME : WIRING DIAGRAM
	DESIGNER : G. DE DONNO	DATE 10/02/22 REVISION 1.3 SCALE 1:1 SIZE A2 PAGE : 2 DI 2
ARCHIVING : "rvrut" SERVER, "RILASCIATI" FOLDER	PROJECT_CODE : 125	DOCUMENT_CODE : <>

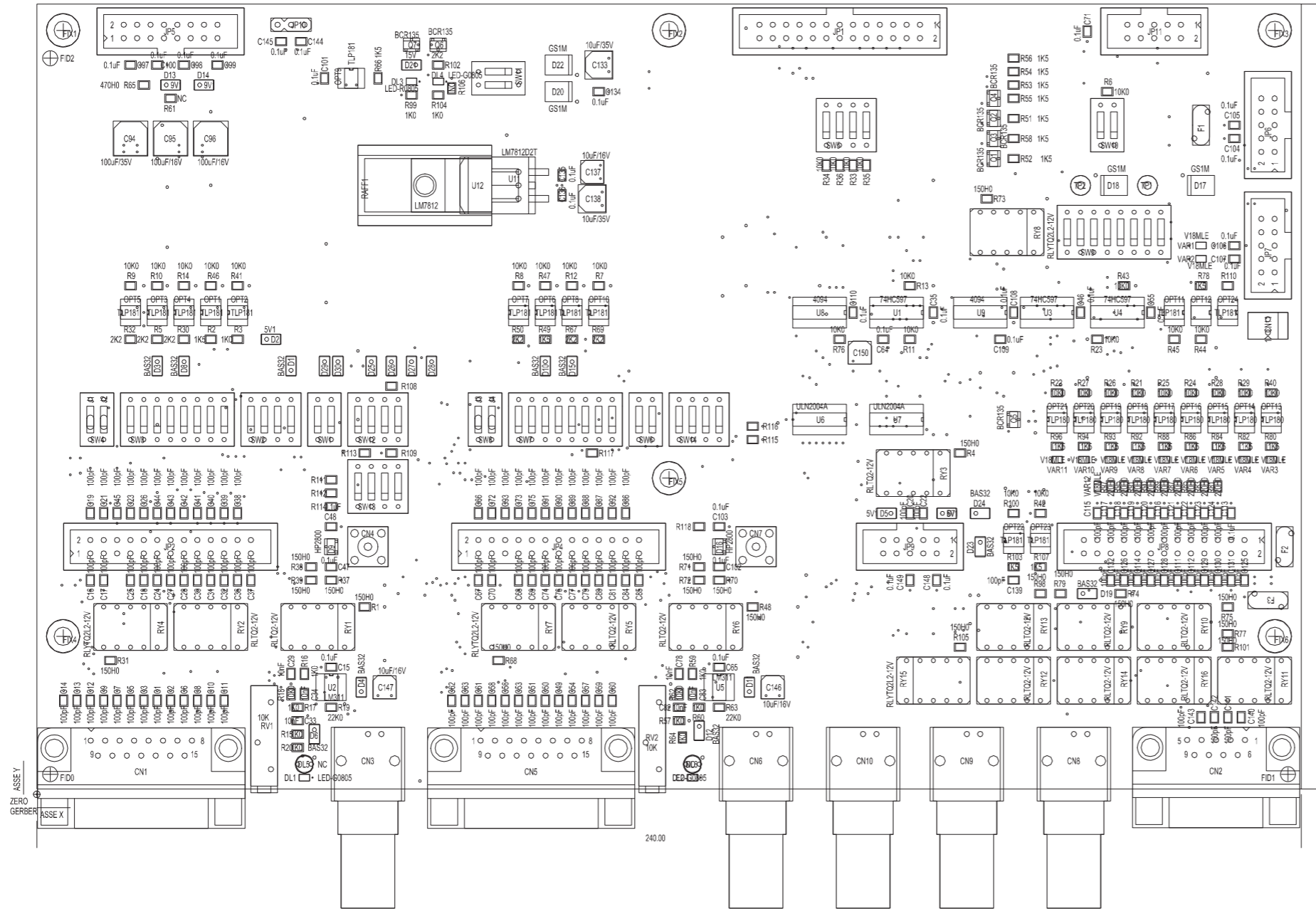

RILASCIO: 22/9/06	DIS. S.POL. CTR. A2 LATO PIANO DI MONTAGGIO VISTA LATO COMPONENTI	
REV:		
DIM.SCHEDA: VEDI QUOTE TRATT.: STANDARD COSTRUTTORE	DENOMINAZIONE SCHEDA MAIN	
MAT.: FR4-74 1.6mm Cu35um VISTA POSITIVA	CODICE CSMA0084R3	RVR ELETTRONICA S.P.A. SCALA 1:1

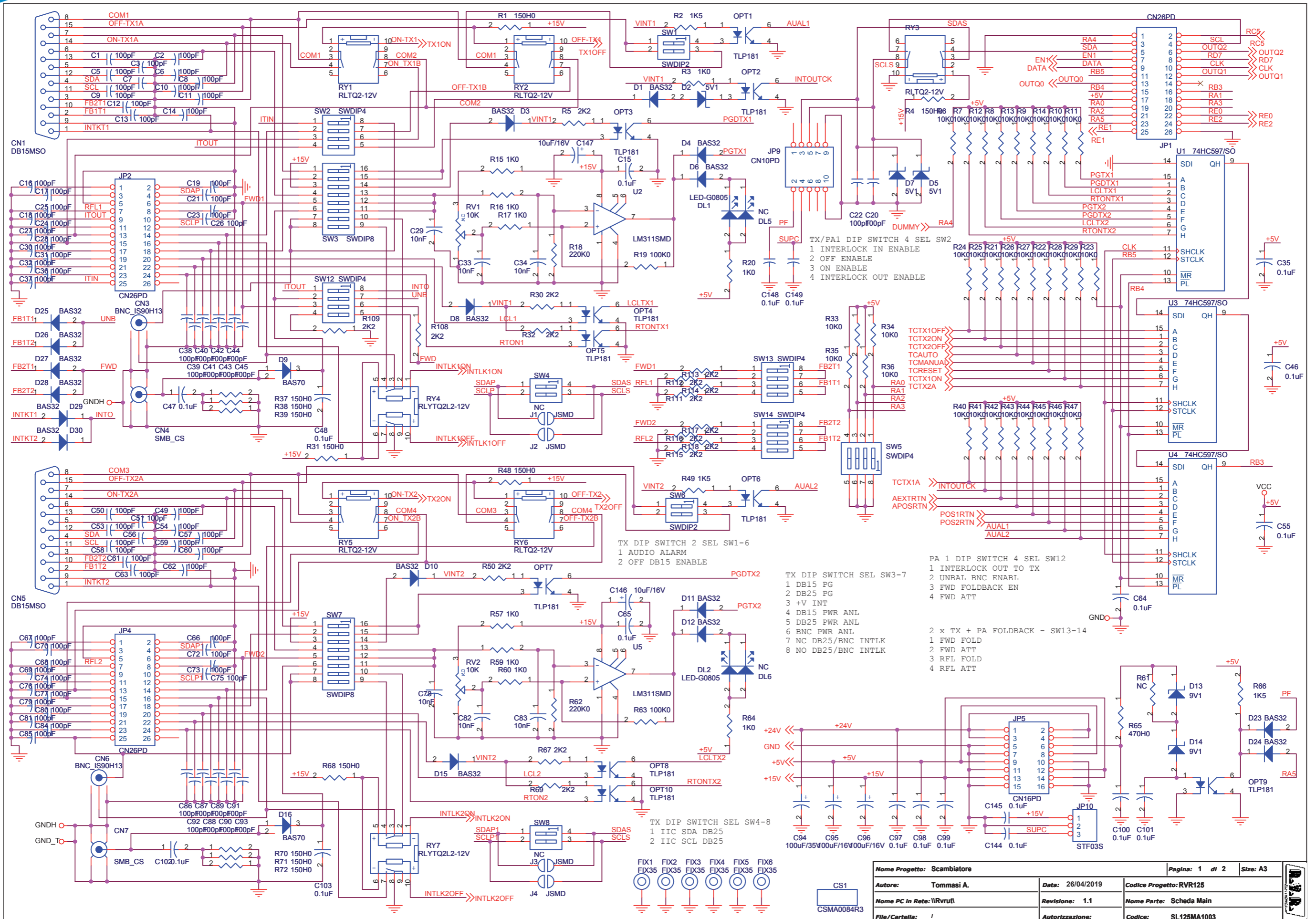

Nome Progetto: Scambiatore	Pagina: 1 di 2	Size: A3
Autore: Tommasi A.	Data: 26/04/2019	Codice Progetto: RVR125
Nome PC in Rete: \Rvruti	Revisione: 1.1	Nome Parte: Scheda Main
File/Cartella: /	Autorizzazione:	Codice: SL125MA1003

SL125MA1003

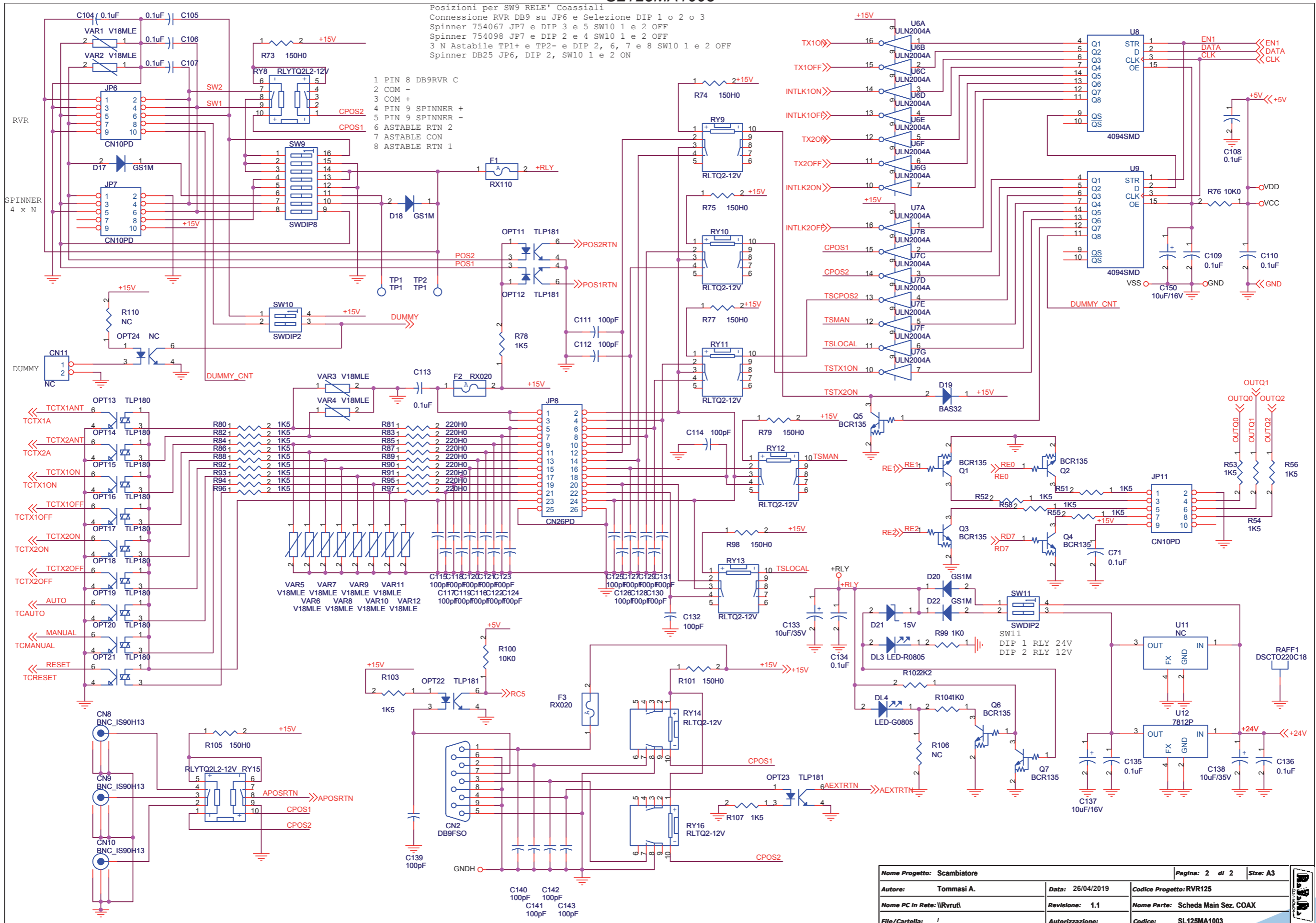

Nome Progetto: Scambiatore		Pagina: 2 di 2		Size: A3
Autore: Tommasi A.	Data: 26/04/2019	Codice Progetto: RVR125		
Nome PC in Rete: \Rvrutl	Revisione: 1.1	Nome Parte: Scheda Main Sez. COAX		
File/Cartella: /	Autorizzazione:	Codice: SL125MA1003		

SL125MA1003

Scheda Main Revised: 26/04/2019
SL125MA1003 Revision: 1.1

Scambiatore
RVR125

Item	Quantity	Reference	Part	Description
1	2	CN1,CN5	DB15MSO	Connettore DB15 mas. cs 90°
2	1	CN2	DB9FSO	Connettore DB9 femm. cs 90°
3	5	CN3,CN6,CN8,CN9,CN10	BNC_IS90H13	Connettore BNC isolato 90° h 13mm
4	2	CN4,CN7	SMB_CS	Connettore SMB cs
5	1	CN11	NC	Connettore 2 poli Mascon
6	1	CS1	CSMA0084R3	Circuito stampato
7	102	C1,C2,C3,C5,C6,C7,C8,C9,C10,C11,C12,C13,C14,C16,C17,C18,C19,C20,C21,C22,C23,C24,C25,C26,C27,C28,C30,C31,C32,C36,C37,C38,C39,C40,C41,C42,C43,C44,C45,C49,C50,C51,C53,C54,C56,C57,C58,C59,C60,C61,C62,C63,C66,C67,C68,C69,C70,C72,C73,C74,C75,C76,C77,C79,C80,C81,C84,C85,C86,C87,C88,C89,C90,C91,C92,C93,C111,C112,C114,C115,C116,C117,C118,C119,C120,C121,C122,C123,C124,C125,C126,C127,C128,C129,C130,C131,C132,C139,C140,C141,C142,C143	100pF	Cond. SMD 0805
8	31	C15,C35,C46,C47,C48,C55,C64,C65,C71,C97,C98,C99,C100,C101,C102,C103,C104,C105,C106,C107,C108,C109,C110,C113,C134,C135,C136,C144,C145,C148,C149	0.1uF	Cond. SMD 0805
9	6	C29,C33,C34,C78,C82,C83	10nF	Cond. SMD 0805
10	1	C94	100uF/35V	Cond. Elett. SMD d. 6.3mm
11	2	C95,C96	100uF/16V	Cond. Elett. SMD d. 6.3mm
12	2	C133,C138	10uF/35V	Cond. Elett. SMD d. 5mm
13	4	C137,C146,C147,C150	10uF/16V	Cond. Elett. SMD d. 4mm
14	3	DL1,DL2,DL4	LED-G0805	LED SMD 0805
15	1	DL3	LED-R0805	LED SMD 0805
16	2	DL5,DL6	NC	LED Verde dia. 3mm
17	18	D1,D3,D4,D6,D8,D10,D11,D12,D15,D19,D23,D24,D25,D26,D27,D28,D29,D30	BAS32	MINIMELF SMD Diode
18	3	D2,D5,D7	5V1	MINIMELF SMD Zener Diode
19	2	D9,D16	BAS70	Diode SMD SOT23
20	2	D13,D14	9V1	MINIMELF SMD Zener Diode
21	4	D17,D18,D20,D22	GS1M	Diode SMD cont. SMB
22	1	D21	15V	MINIMELF SMD Zener Diode
23	6	FIX1,FIX2,FIX3,FIX4,FIX5, FIX6	FIX35	Foro fissaggio 3.5mm
24	1	F1	RX110	Fusibile autorip. RUE p5mm
25	2	F2,F3	RX020	Fusibile autorip. RUE p5mm
26	4	JP1,JP2,JP4,JP8	CN26PD	Connettore 26 poli Flat cs
27	1	JP5	CN16PD	Connettore 16 poli Flat cs
28	4	JP6,JP7,JP9,JP11	CN10PD	Connettore 10 poli Flat cs
29	1	JP10	NC	Strip femmina 3 pin
30	4	J1,J2,J3,J4	JSMD	Pad SMD a saldare
31	14	OPT1,OPT2,OPT3,OPT4,OPT5, OPT6,OPT7,OPT8,OPT9, OPT10,OPT11,OPT12,OPT22, OPT23	TLP181	Optoisolatore SMD SO6
32	9	OPT13,OPT14,OPT15,OPT16, OPT17,OPT18,OPT19,OPT20, OPT21	TLP180	Optoisolatore SMD SO6
33	1	OPT24	NC	Optoisolatore SMD SO6

34	7	Q1,Q2,Q3,Q4,Q5,Q6,Q7	BCR135	Trans./Res. NPN SOT23
35	1	RAFF1	DSCTO220C18	Dissipatore TO220
36	2	RV1,RV2	10K	Trimmer Rg H 3006
37	12	RY1,RY2,RY3,RY5,RY6,RY9, RY10,RY11,RY12,RY13,RY14, RY16	RLTQ2-12V	Rele' TQ2
38	4	RY4,RY7,RY8,RY15	RLYTQ2L2-12V	Rele' TQ2L2
39	19	R1,R4,R31,R37,R38,R39, R48,R68,R70,R71,R72,R73, R74,R75,R77,R79,R98,R101, R105	150H0	Res. SMD 0805
40	22	R2,R49,R51,R52,R53,R54, R55,R56,R58,R66,R78,R80, R82,R84,R86,R88,R92,R93, R94,R96,R103,R107	1K5	Res. SMD 0805
41	11	R3,R15,R16,R17,R20,R57, R59,R60,R64,R99,R104	1K0	Res. SMD 0805
42	17	R5,R30,R32,R50,R67,R69, R102,R108,R109,R111,R112, R113,R114,R115,R116,R117, R118	2K2	Res. SMD 0805
43	32	R6,R7,R8,R9,R10,R11,R12, R13,R14,R21,R22,R23,R24, R25,R26,R27,R28,R29,R33, R34,R35,R36,R40,R41,R42, R43,R44,R45,R46,R47,R76, R100	10K0	Res. SMD 0805
44	2	R18,R62	220K0	Res. SMD 0805
45	2	R19,R63	100K0	Res. SMD 0805
46	3	R61,R106,R110	NC	Res. SMD 0805
47	1	R65	470H0	Res. SMD 0805
48	9	R81,R83,R85,R87,R89,R90, R91,R95,R97	220H0	Res. SMD 0805
49	4	SW1,SW6,SW10,SW11	SWDIP2	Dip switch 2 vie
50	5	SW2,SW5,SW12,SW13,SW14	SWDIP4	Dip switch 4 vie
51	3	SW3,SW7,SW9	SWDIP8	Dip switch 8 vie
52	2	SW4,SW8	NC	Dip switch 2 vie
53	2	TP1,TP2	TP1	Test point
54	3	U1,U3,U4	74HC597/SO	Shift Reg. SMD SO16
55	2	U2,U5	LM311SMD	Comp. SMD SO8
56	2	U6,U7	ULN2004A	Seven Inv. Buffer OC
57	2	U8,U9	4094SMD	Shift Reg. SMD SO16
58	1	U11	NC	Stabilizzatore SMD D2PAK
59	1	U12	7812P	Stabilizzatore TO220
60	12	VAR1,VAR2,VAR3,VAR4,VAR5, VAR6,VAR7,VAR8,VAR9, VAR10,VAR11,VAR12	V18MLE	ESD SMD protector

SL125PC1001

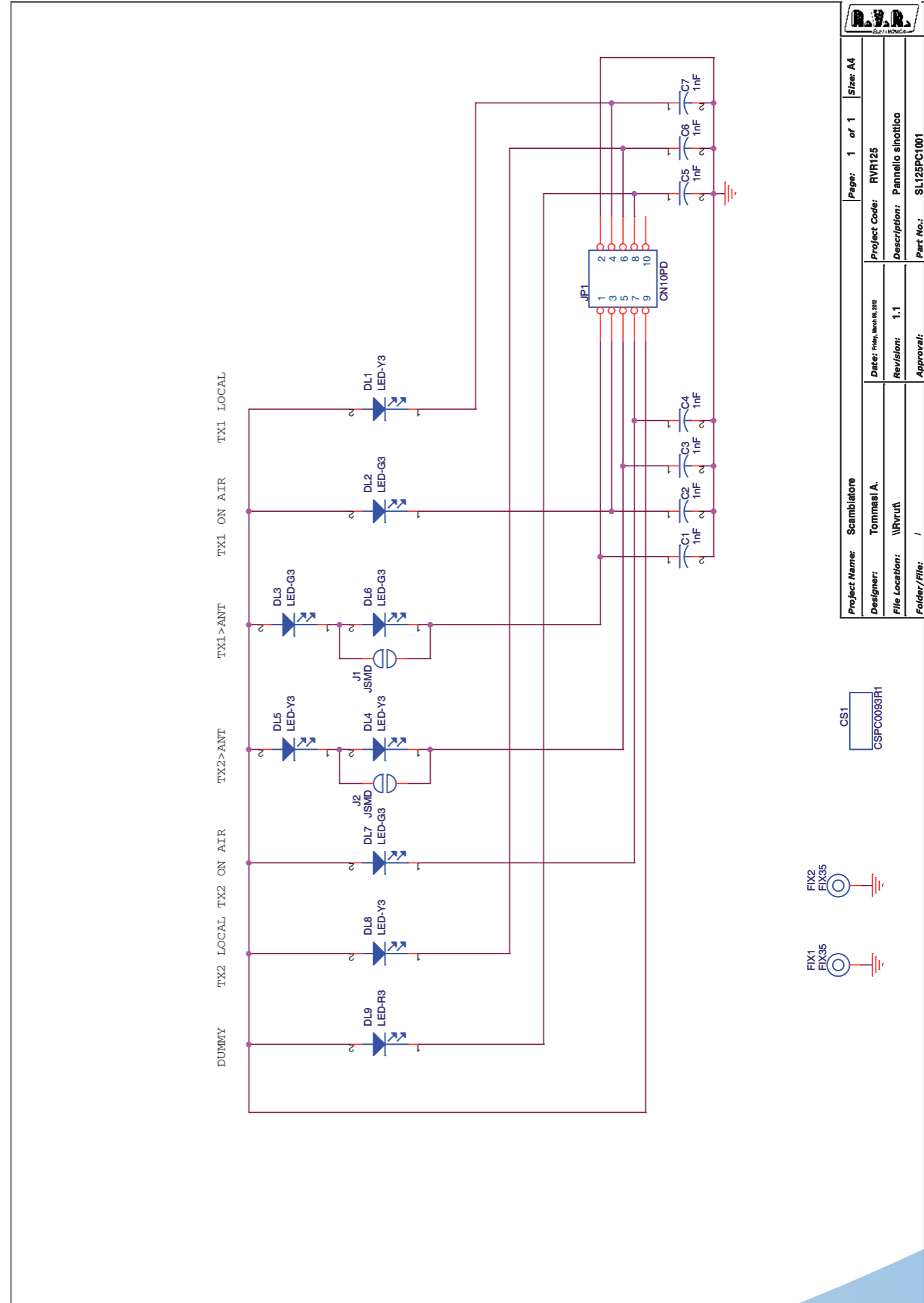
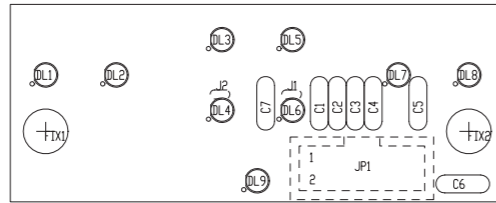

		Page: 1 of 1	Size: A4
Project Name: Scambiatore	Designer: Tommasi A.	Project Code: RVR125	Description: Pannello sinottico
Date: mm/aa/aa	Revision: 1.1	Folder/File:	Part No.: SL125PC1001
File Location: \\RVRut	Approval:		

	PRODUCT NAME : SCMLCD1+1SL	PART NAME : SYNOPTIC PANEL
DESIGNER : A. TOMMASI	DATE : 03/08/200	REVISION : 1.0
ARCHIVING : 'RVRUT' SERVER, 'RILASCIATI' FOLDER	PROJECT CODE : 125	DOCUMENT CODE : SL125PC1001
	SCALE : 1:1	SIZE : A4
		PAGE : 1 DI 1

SL125PC1001

Pannello sinottico
SL125PC1001
Rev.1.1 09/03/2012
Scambiatore
RVR125
Tommasi A.

Item	Quantity	Reference	Part	Description
1	1	CS1	CSPC0093R1	Circuito stampato
2	7	C1,C2,C3,C4,C5,C6,C7	1nF	Cond. ceramico p 5mm
3	4	DL1,DL8,DL4,DL5	LED-Y3	LED Giallo dia. 3mm
4	4	DL2,DL3,DL6,DL7	LED-G3	LED Verde dia. 3mm
5	1	DL9	LED-R3	LED Rosso dia. 3mm
6	2	FIX1,FIX2	FIX35	Foro fissaggio 3.5mm
7	1	JP1	CN10PD	Connettore 10 poli Flat cs
8	2	J1,J2	JSMD	Pad SMD a saldare

SLPC0435R01V03

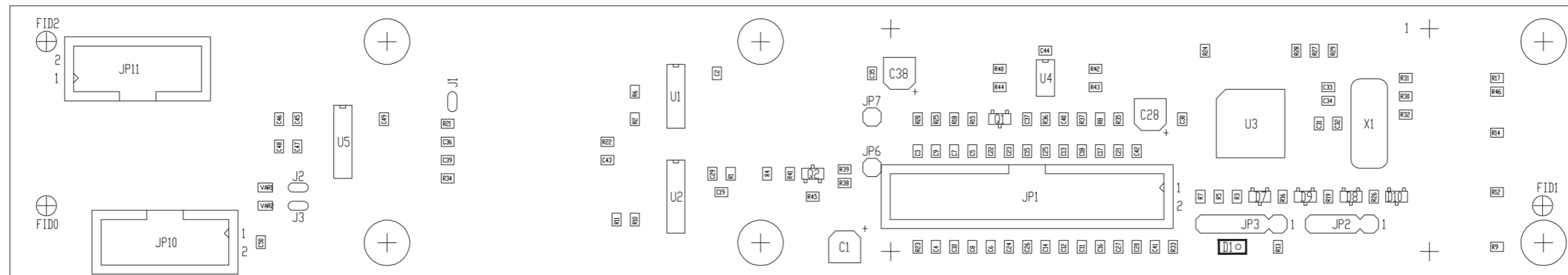
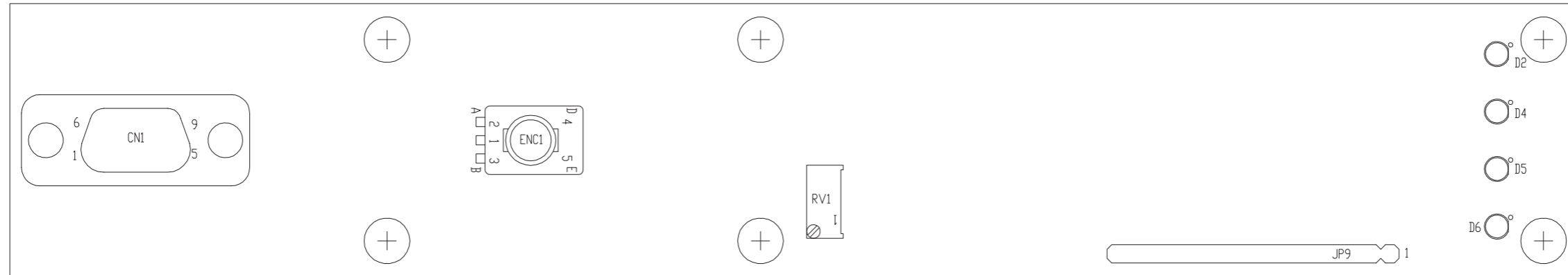

PRODUCT NAME : BLUESNV, PTRL, RXRL, SCM1+1SL	PART NAME : SEM.SCH.PANEL CARD PIC18F452 IU
DESIGNER : A. TOMMASI	DATE : 09/09/15
ARCHIVING : "RVUT" SERVER, "RILASCIATI" FOLDER	REVISION : 1.0
PROJECT CODE : <>	SCALE : 1:1
	SIZE : A4
	PAGE : 1
	DI : 1
	DOCUMENT CODE : SLPC0435R01V01



SLPC0435R01V03

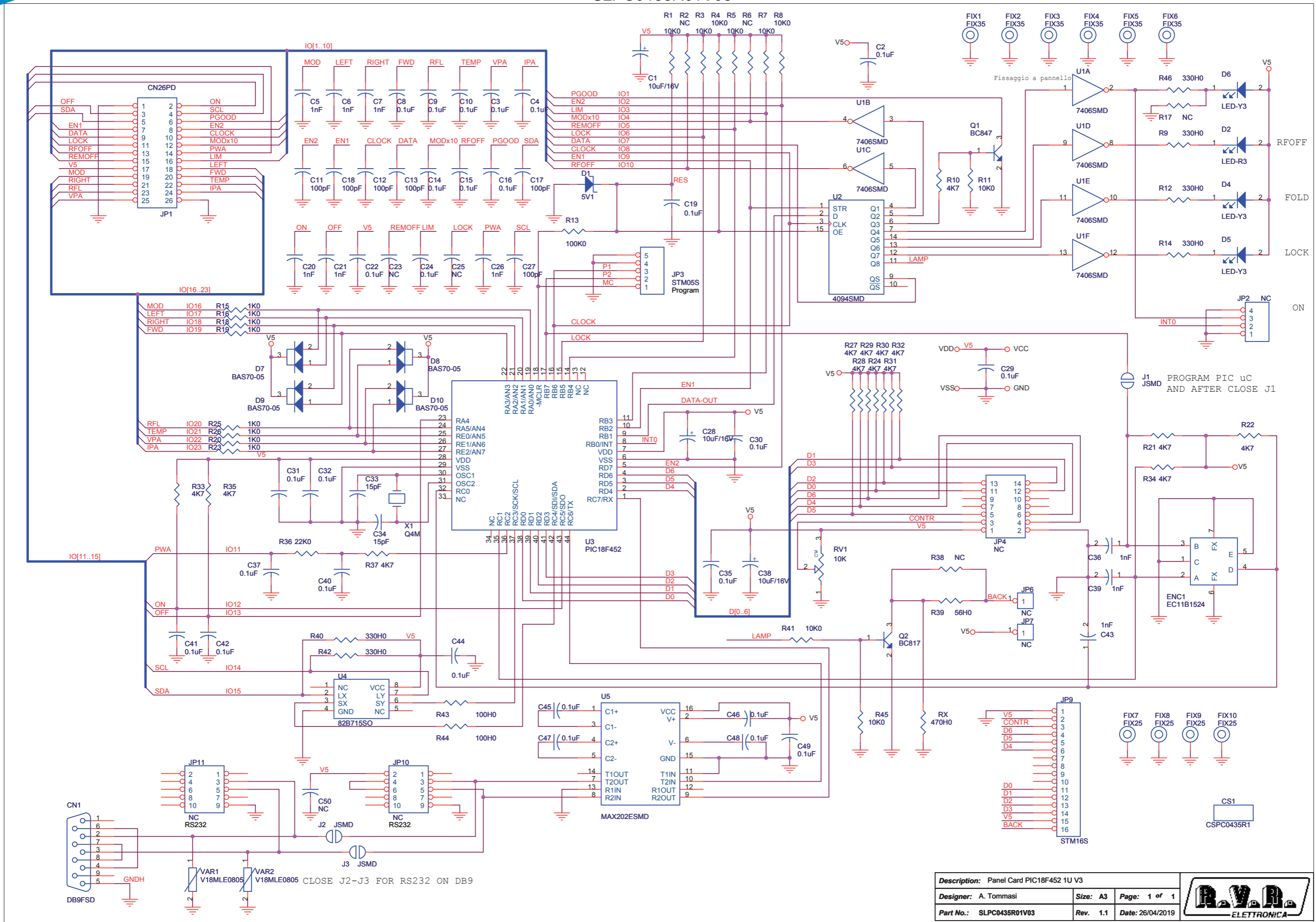

Description: Panel Card PIC18F452 1U V3		
Designer: A. Tommasi	Size: A3	Page: 1 of 1
Part No.: SLPC0435R01V03	Rev.: 1.1	Date: 26/04/2019



SLPC0435R01V03

Panel Card PIC18F452 1U V3
 SLPC0435R01V03
 Rev.1.1 26/04/2018
 A. Tommasi

Item	Quantity	Reference	Part	Description
1	1	CN1	DB9FSD	Connettore DB9 femm. cs
2	1	CS1	CSPC0435R1	Circuito stampato
3	3	C1,C28,C38	10uF/16V	Cond. Elett. SMD d. 4mm
4	27	C2,C3,C4,C8,C9,C10,C14, C15,C16,C19,C22,C24, C29,C30,C31,C32,C35, C37,C40,C41,C42,C44,C45, C46,C47,C48,C49	0.1uF	Cond. SMD 0805
5	9	C5,C6,C7,C20,C21,C26,C36, C39,C43	1nF	Cond. SMD 0805
6	6	C11,C12,C13,C17,C18,C27	100pF	Cond. SMD 0805
7	2	C33,C34	15pF	Cond. SMD 0805
8	3	C23,C25,C50	NC	Cond. SMD 0805
9	1	D1	5V1	MINIMELF SMD Zener Diode
10	1	D2	LED-R3	LED dia. 3mm
11	3	D4,D5,D6	LED-Y3	LED dia. 3mm
12	4	D7,D8,D9,D10	BAS70-05	Doppio Diodo SMD SOT23
13	1	ENC1	EC11B1524	Incremental encoder ALPS EC11
14	6	FIX1,FIX2,FIX3,FIX4,FIX5, FIX6	FIX35	Foro fissaggio
15	4	FIX7,FIX8,FIX9,FIX10	FIX25	Foro fissaggio 2.5mm
16	1	JP1	CN26PD	Connettore 26 poli Flat cs
17	1	JP2	NC	Strip maschio 4 pin
18	1	JP3	STM05S	Strip maschio 5 pin
19	1	JP4	NC	Strip maschio 14 pin doppia fila
20	2	JP6,JP7	NC	Strip femmina 1 pin
21	1	JP9	STM16S	Strip maschio 16 pin
22	2	JP10,JP11	NC	Connettore 10 poli Flat cs
23	1	J1	JSMD	Pad SMD a saldare
24	2	J2,J3	JSMD	
25	1	Q1	BC847	Trans. NPN SOT23
26	1	Q2	BC817	Trans. NPN SOT23
27	1	RV1	10K	Trimmer Rg V 3296W
28	9	R1,R3,R4,R5,R7,R8, R11,R41,R45	10K0	Res. SMD 0805
29	1	R13	100K0	Res. SMD 0805
30	6	R9,R12,R14,R40,R42,R46	330H0	Res. SMD 0805
31	14	R10,R21,R22,R24,R27,R28, R29,R30,R31,R32,R33,R34, R35,R37	4K7	Res. SMD 0805
32	8	R15,R16,R18,R19,R20,R23, R25,R26	1K0	Res. SMD 0805
33	4	R2,R6,R17,R38	NC	Res. SMD 0805
34	1	R36	22K0	Res. SMD 0805
35	1	R39	56H0	Res. SMD 0805
36	2	R43,R44	100H0	Res. SMD 0805
37	1	RX	470H0	Res. SMD 0805
38	1	U1	7406SMD	Hex inv OC SMD SO14
39	1	U2	4094SMD	Shift Reg. SMD SO16
40	1	U3	PIC18F452	TQFP44 SMD Microprocessor
41	1	U4	82B715SO	IIC Bus driver SMD SO8
42	1	U5	MAX202ESMD	RS232 Driver SMD SO16
43	2	VAR1,VAR2	V18MLE0805	ESD SMD protector
44	1	X1	Q4M	Quarzo SMD HC49SMD



65W Single Output Switching Power Supply **EPS-65S** series

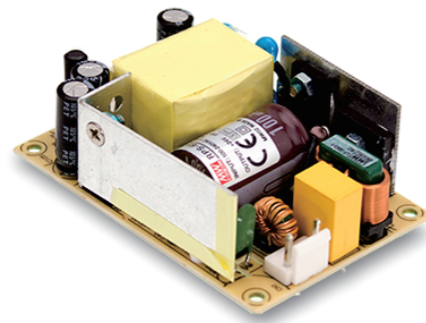

■ Features

- 3"×2" miniature size
- Universal AC input / Full range
- Class II (without FG) installations
- No load power consumption<0.1W
- High efficiency up to 91%
- For 1U applications
- Protections: Short circuit / Overload / Over voltage
- Cooling by free air convection
- -30~70°C wide range of operating temperature
- Operating altitude up to 5000 meters
- LED indicator for power on
- 3 years warranty

■ Description

EPS-65S is a 65W highly reliable green PCB type industrial power supply with a high power density on the 3" by 2" footprint. It accepts 80~264VAC input and offers various output voltages between 3.3V and 48V. The working efficiency is up to 91% and the extremely low no load power consumption is down below 0.1W. EPS-65S is able to be used for Class II (no FG) system design.

■ Model Encoding

EPS-65S-3.3

- Output voltage
- Small size
- Output wattage
- Series name

File Name:EPS-65S-SPEC 2018-06-21



65W Single Output Switching Power Supply **EPS-65S** series

SPECIFICATION

ORDER NO.	EPS-65S-3.3	EPS-65S-5	EPS-65S-7.5	EPS-65S-12	EPS-65S-15	EPS-65S-24	EPS-65S-48	
OUTPUT	DC VOLTAGE	3.3V	5V	7.5V	12V	15V	24V	48V
	RATED CURRENT	10A	10A	8A	5.42A	4.34A	2.71A	1.36A
	CURRENT RANGE	0 ~ 11A	0 ~ 11A	0 ~ 8.8A	0 ~ 5.96A	0 ~ 4.77A	0 ~ 2.98A	0 ~ 1.49A
	RATED POWER	33W	50W	60W	65W	65.1W	65W	65.3W
	PEAK LOAD(10sec.) Note.2	36.3W	55W	66W	71.5W	71.6W	71.5W	71.5W
	RIPPLE & NOISE (max.) Note.3	80mVp-p	80mVp-p	80mVp-p	120mVp-p	150mVp-p	240mVp-p	300mVp-p
	VOLTAGE ADJ.RANGE	2.9~3.6V	4.7~5.5V	7.12~8.3V	11.4~13.2V	13.5~16.5V	22.8~27.6V	45.6~52.8V
	VOLTAGE TOLERANCE Note.4	±2.0%	±2.0%	±2.0%	±2.0%	±1.0%	±1.0%	±1.0%
	LINE REGULATION	±0.5%	±0.5%	±0.5%	±0.5%	±0.5%	±0.5%	±0.5%
	LOAD REGULATION	±2.0%	±2.0%	±2.0%	±2.0%	±1.0%	±1.0%	±1.0%
SETUP, RISE TIME	500ms, 30ms / 230VAC 500ms, 30ms / 115VAC at full load							
HOLD UP TIME (Typ.)	30ms / 230VAC 12ms / 115VAC at full load							
INPUT	VOLTAGE RANGE Note.5	80 ~ 264VAC						
	FREQUENCY RANGE	47 ~ 63Hz						
	EFFICIENCY (Typ.)	80%	84%	85%	88%	89%	90%	91%
	AC CURRENT (Typ.)	1.5A / 115VAC 1A / 230VAC						
	INRUSH CURRENT (Typ.)	COLD STAR 30A/115VAC 50A/230VAC						
	LEAKAGE CURRENT(max.)	0.25mA/264VAC						
PROTECTION	OVERLOAD	115 ~ 150% rated output power Protection type : Hiccup mode, recovers automatically after fault condition is removed						
	OVER VOLTAGE	3.8~4.46V	5.75~6.75V	8.62~11.3V	13.8~16.2V	17.25~20.25V	27.6~32.4V	55.2~64.8V
ENVIRONMENT	WORKING TEMP.	-30 ~ +70°C (Refer to "Derating Curve")						
	WORKING HUMIDITY	20% ~ 90% RH non-condensing						
	STORAGE TEMP., HUMIDITY	-40 ~ +85°C, 10 ~ 95% RH						
	TEMP. COEFFICIENT	±0.03% / °C (0 ~ 50°C)						
	OPERATING ALTITUDE Note.6	5000 meters						
SAFETY & EMC (Note. 7)	VIBRATION	10 ~ 500Hz, 2G 10min./1cycle, period for 60min. each along X, Y, Z axes						
	SAFETY STANDARDS	UL60950-1, TUV EN60950-1, EAC TP TC 004 approved						
	ISOLATION LEVEL	Primary-Secondary: 2xMOPP						
	WITHSTAND VOLTAGE	I/P-O/P: 3KVAC						
OTHERS	ISOLATION RESISTANCE	I/P-O/P:100M Ohms / 500VDC / 25°C / 70% RH						
	EMC EMISSION	Compliance to EN55032(CISPR32) Class B, EN61000-3-2,3, EAC TP TC 020						
	EMC IMMUNITY	Compliance to EN61000-4-2,3,4,5,6,8,11, EN55024, Heavy industry Level criteria A, EAC TP TC 020						
NOTE	MTBF	959.1Khrs min. MIL-HDBK-217(25°C)						
	DIMENSION	76.2*50.8*24mm or 3" * 2" * 0.945" inch (L*W*H)						
	PACKING	0.11Kg; 120pcs/14.2Kg/0.97CUFT						
<p>1. All parameters NOT specially mentioned are measured at 230VAC input, rated load and 25°C of ambient temperature.</p> <p>2. 33% Duty cycle maximum within every 30 seconds. Average output power should not exceed the rated power.</p> <p>3. Ripple & noise are measured at 20MHz of bandwidth by using a 12" twisted pair-wire terminated with a 0.1uf & 47uf parallel capacitor.</p> <p>4. Tolerance : includes set up tolerance, line regulation and load regulation.</p> <p>5. Derating may be needed under low input voltages. Please check the derating curve for more details.</p> <p>6. The ambient temperature derating of 3.5°C/1000m with fanless models and of 5°C/1000m with fan models for operating altitude higher than 2000m(6500ft).</p> <p>7. The power supply is considered a component which will be installed into a final equipment. The final equipment must be re-confirmed that it still meets EMC directives. For guidance on how to perform these EMC tests, please refer to "EMI testing of component power. (as available on http://www.meanwell.com)</p>								

File Name:EPS-65S-SPEC 2018-06-21

PS.EPS65S24



65W Single Output Switching Power Supply **EPS-65S** series

■ Block Diagram

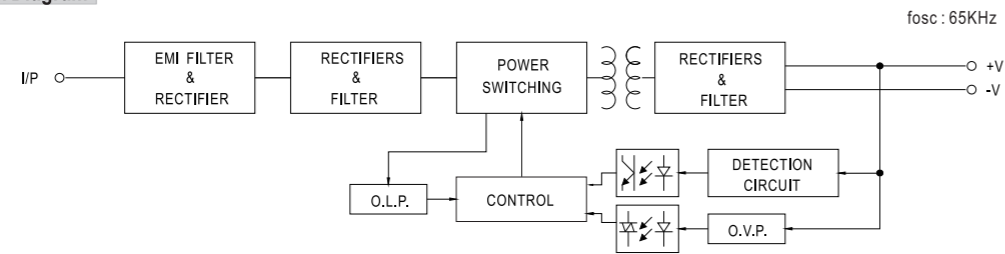

■ Derating Curve

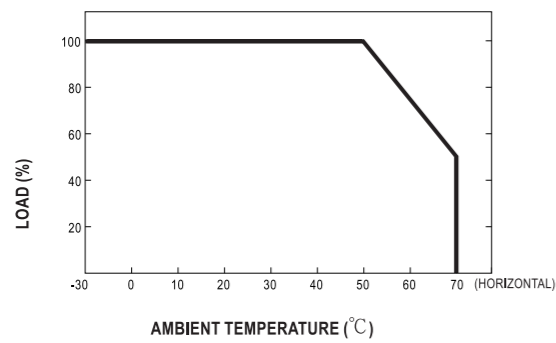

■ Static Characteristics

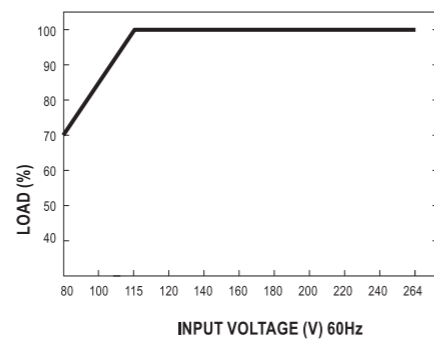

File Name:EPS-65S-SPEC 2018-06-21



65W Single Output Switching Power Supply **EPS-65S** series

■ Mechanical Specification

Case No. Unit:mm

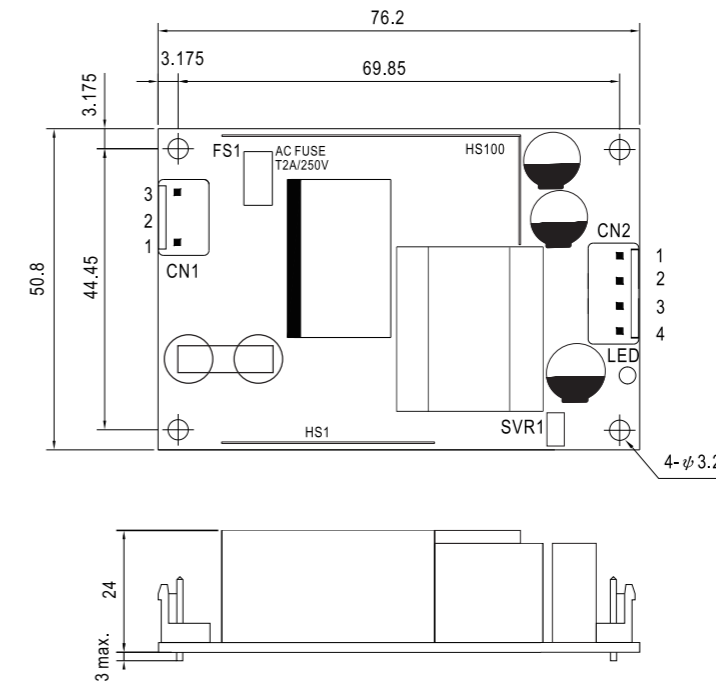

AC Input Connector (CN1) : JST B3P-VH or equivalent

Pin No.	Assignment	Mating Housing	Terminal
1	AC/N	JST VHR or equivalent	JST SVH-21T-P1.1 or equivalent
2	No Pin		
3	AC/L		

DC Output Connector (CN2) : JST B2P-VH or equivalent

Pin No.	Assignment	Mating Housing	Terminal
1	+V	JST VHR or equivalent	JST SVH-21T-P1.1 or equivalent
2	+V		
3	-V		
4	-V		

■ Installation Manual

Please refer to : <http://www.meanwell.com/manual.html>

File Name:EPS-65S-SPEC 2018-06-21

SLPS0482R02V03

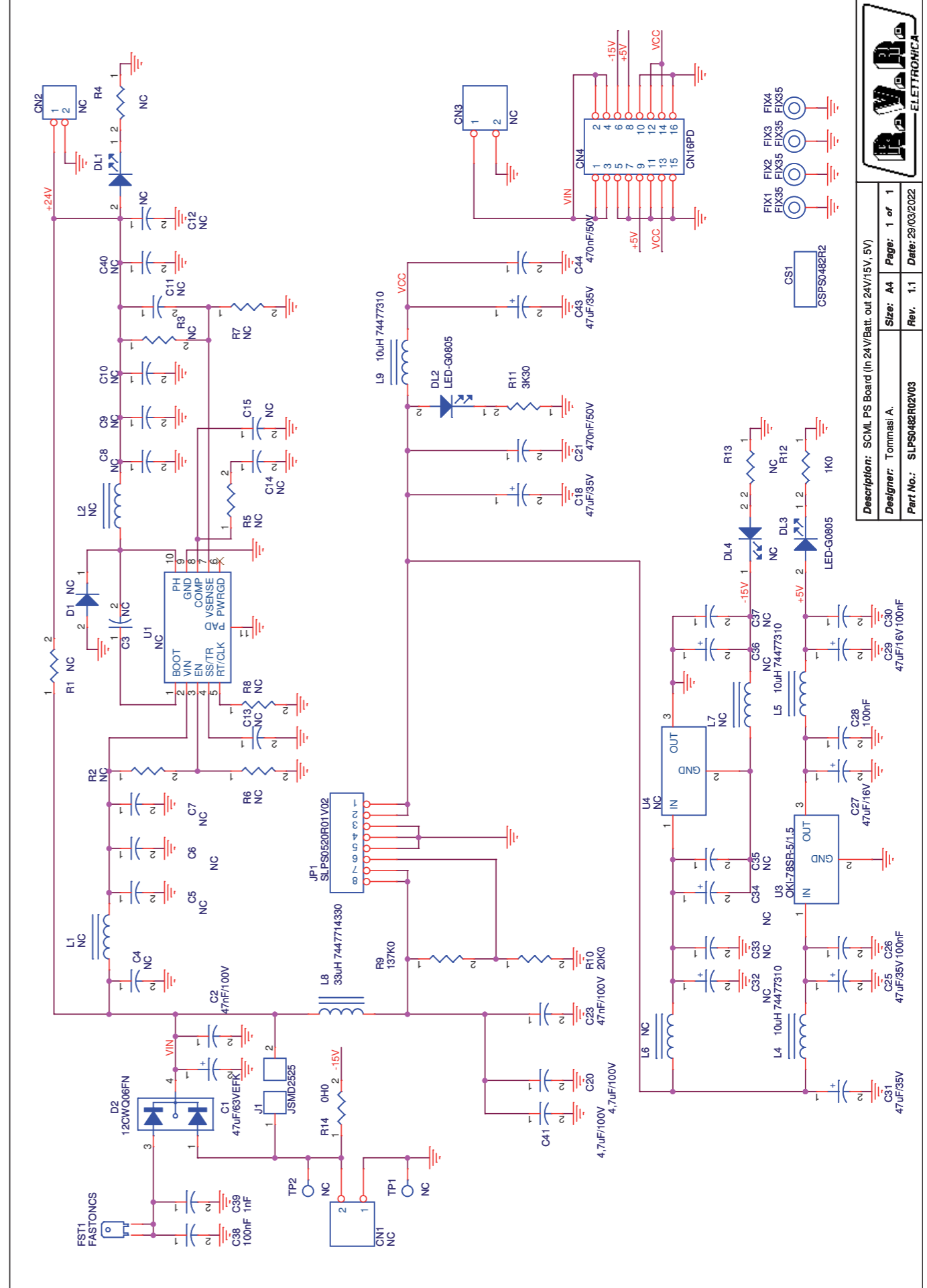
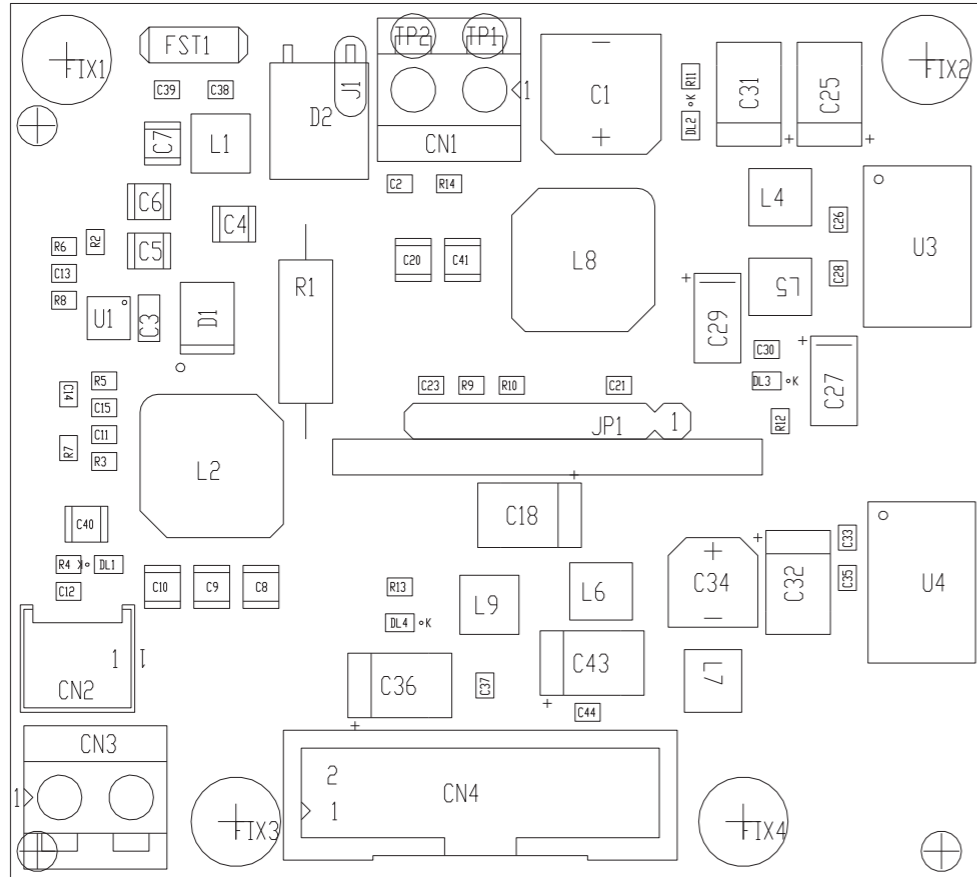

	PRODUCT NAME : <>	PART NAME : POWER SUPPLY				
	DESIGNER : A. TOMMASI	DATE : 08/02/22	REVISION : 1.0	SCALE : 2:1	SIZE : A4	PAGE : 1 DI 1
	ARCHIVING : "RVVUT" SERVER, "RILASCIATI" FOLDER	PROJECT CODE : <>	DOCUMENT CODE : SLPS0482R01VXX			

Description: SCML PS Board (in 24V/Batt. out 24V/15V, 5V)	Page: 1 of 1
Designer: Tommasi A.	Size: A4
Part No.: SLPS0482R02V03	Rev. 1.1
Date: 29/03/2022	

SLPS0482R02V03

SCML PS Board (In 24V/Batt. out 24V/15V, 5V) Revised: 29/03/2022
 SLPS0482R02V03 Revision: 1.1
 Tommasi A.

Item	Quantity	Reference	Part	Description
1	2	CN1, CN3	NC	KRA Conn. a 2 poli
2	1	CN2	NC	2 way Lumberg conn. MSF p 2.5mm
3	1	CN4	CN16PD	16 way pcb conn. with holder
4	1	CS1	CSPS0482R2	Printed Circuit board
5	1	C1	47uF/63VEFK	SMD electr. cap. 8mm
6	2	C2, C23	47nF/100V	0805 SMD capacitor
7	1	C3	NC	1206 SMD capacitor
8	7	C4, C5, C6, C7, C8, C9, C10	NC	1210 SMD capacitor
9	2	C11, C15	NC	0805 COG SMD capacitor
10	6	C12, C13, C14, C33, C35, C37	NC	0805 SMD capacitor
11	4	C18, C25, C31, C43	47uF/35V	SMD tantalium cap. size D
12	2	C20, C41	4,7uF/100V	1210 SMD capacitor
13	2	C21, C44	470nF/50V	0805 SMD capacitor
14	4	C26, C28, C30, C38	100nF	0805 SMD capacitor
15	2	C27, C29	47uF/16V	SMD tantalium cap. size C
16	2	C32, C36	NC	SMD tantalium cap. size D
17	1	C34	NC	SMD electr. cap. 6.3mm
18	1	C39	1nF	0805 SMD capacitor
19	1	C40	NC	1210 SMD capacitor
20	2	DL1, DL4	NC	Green LED SMD 0805
21	2	DL2, DL3	LED-G0805	Green LED SMD 0805
22	1	D1	NC	SMD diode case SMB
23	1	D2	12CWQ06FN	Dual diode schottky SMD DPAK
24	4	FIX1, FIX2, FIX3, FIX4	FIX35	3.5mm Fixing hole
25	1	FST1	FASTONCS	PCB faston p. 5.08
26	1	JP1	SLPS0520R01V02	Switching PS Board
27	1	J1	JSMD2525	SMD pad 2 x 2.5x2.5 mm
28	1	L1	NC	Wurth LQS40xx series inductor
29	1	L2	NC	Wurth PD10xx series inductor
30	3	L4, L5, L9	10uH 74477310	SMD Vertical Ind. WE PD2 series
31	2	L6, L7	NC	SMD Vertical Ind. WE PD2 series
32	1	L8	33uH 7447714330	Wurth PD10xx series inductor
33	1	R1	NC	2W resistor
34	8	R2, R3, R4, R5, R6, R7, R8, R13	NC	0805 1% SMD res.
35	1	R9	137K0	0805 1% SMD res.
36	1	R10	20K0	0805 1% SMD res.
37	1	R11	3K30	0805 1% SMD res.
38	1	R12	1K0	0805 1% SMD res.
39	1	R14	0H0	0805 1% SMD res.
40	2	TP1, TP2	NC	TP Hole dia. 1.3mm
41	1	U1	NC	Step down DC2DC conv.
42	1	U3	OKI-78SR-5/1.5	Switch. voltage reg. SIP3
43	1	U4	NC	Switch. voltage reg. SIP3

SLPS0520R01V02

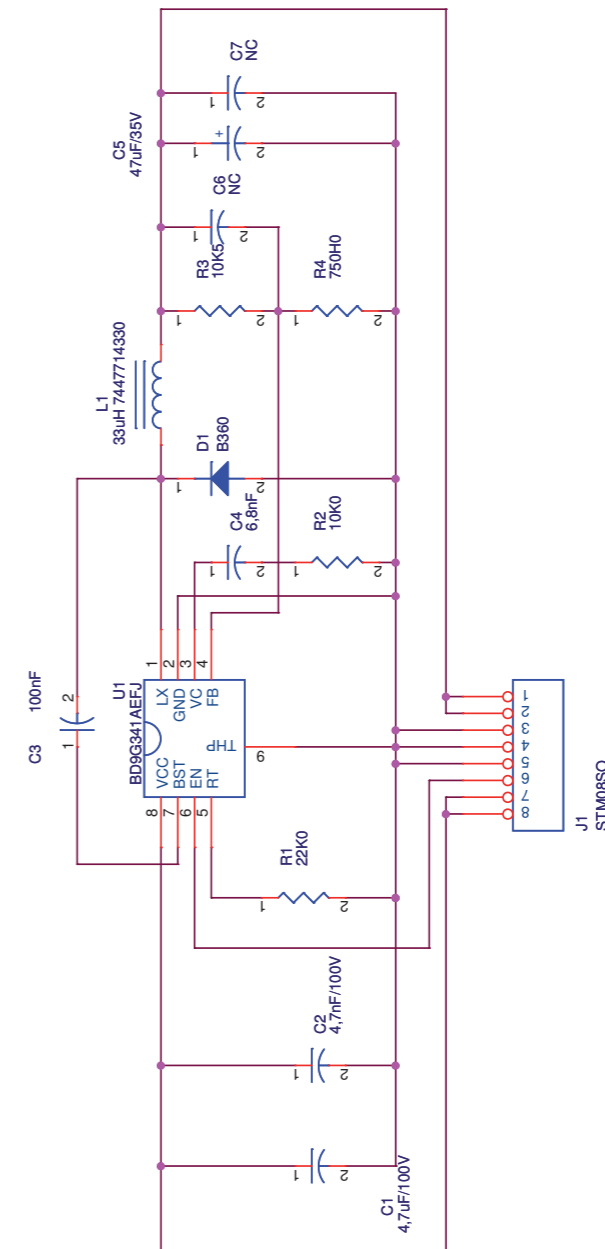
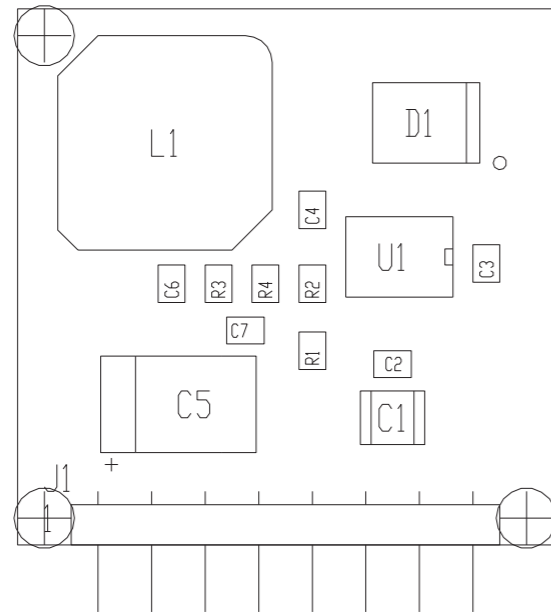

	PRODUCT NAME : POWER SUPPLY	PART NAME : 18V SWITCHING POWER SUPPLY MODULE				
	DESIGNER : A. TOMMASI	DATE : 12/11/21	REVISION : 1.0	SCALE : 3:1	SIZE : A4	PAGE : 1 DI 1
ARCHIVING : "RVTRUT" SERVER, "RILASCIATI" FOLDER		PROJECT CODE : <	DOCUMENT CODE : SLPS0520R01VXX			

Description: 15V Switching Power Supply Module	Page: 1 of 1
Designer: A. Tommasi	Size: A4
Part No.: SLPS0520R01V02	Rev: 1.0
Date: 12/11/2021	

CS1
CSPS0520R1

SLPS0520R01V02

15V Switching Power Supply Module Revised: Friday, November 12, 2021

SLPS0520R01V02 Revision: 1.0

A. Tommasi

Item	Quantity	Reference	Part	Description
1	1	CS1	CSPS0520R1	Printed Circuit board
2	1	C1	4,7uF/100V	1210 SMD capacitor
3	1	C2	4,7nF/100V	0805 SMD capacitor
4	1	C3	100nF	0805 SMD capacitor
5	1	C4	6,8nF	0805 SMD capacitor
6	1	C5	47uF/35V	SMD tantalium cap. size D
7	2	C6, C7	NC	0805 SMD capacitor
8	1	D1	B360	SMD diode cont. SMB
9	1	J1	STM08SO	Male strip 8 pin 90°
10	1	L1	33uH 7447714330	Würth PD10xx series inductor
11	1	R1	22K0	0805 SMD res.
12	1	R2	10K0	0805 SMD res.
13	1	R3	10K5	0805 SMD res.
14	1	R4	750H0	0805 SMD res.
15	1	U1	BD9G341AEFJ	Switching regulator

SL125IN1001

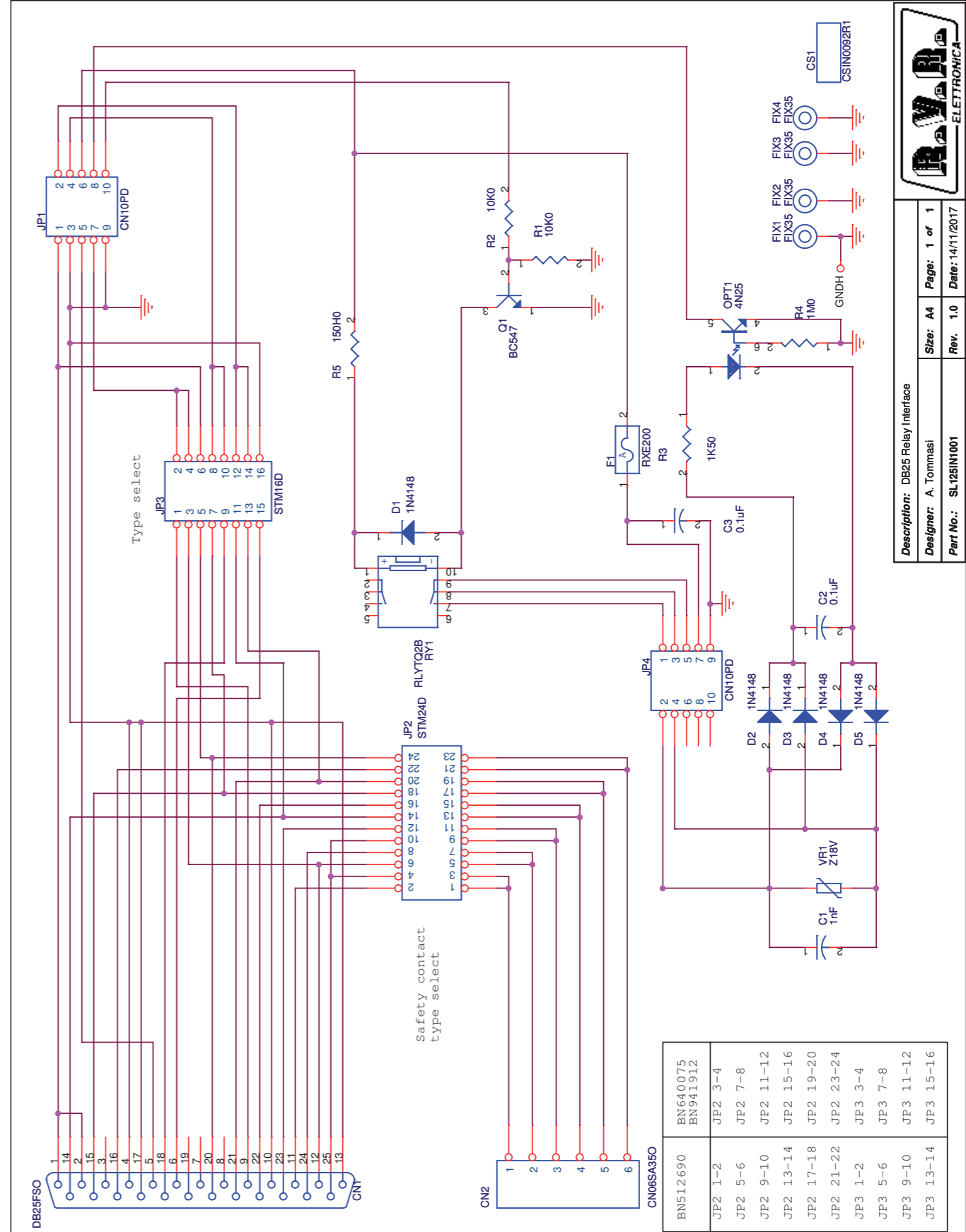
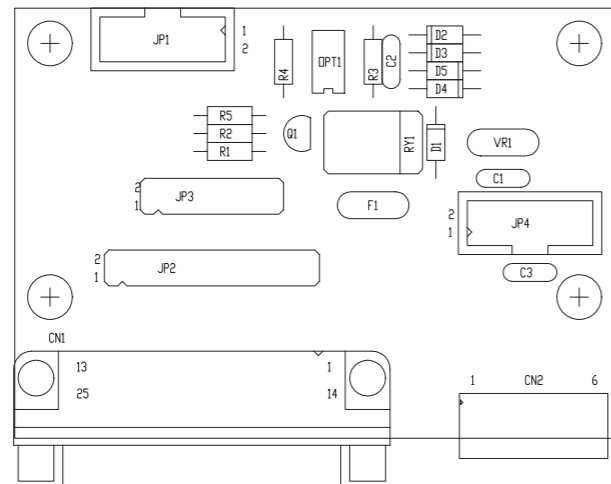

BN512690	JP2 1-2	BN640075	JP2 3-4
	JP2 5-6	BN941912	JP2 7-8
	JP2 9-10		JP2 11-12
	JP2 13-14		JP2 15-16
	JP2 17-18		JP2 19-20
	JP2 21-22		JP2 23-24
	JP3 1-2		JP3 3-4
	JP3 5-6		JP3 7-8
	JP3 9-10		JP3 11-12
	JP3 13-14		JP3 15-16

Description: DB25 Relay Interface
 Designer: A. Tommasi
 Part No.: SL125IN1001
 Size: A4
 Page: 1 of 1
 Rev. 1.0
 Date: 14/11/2017

	PRODUCT NAME : SCMLCD1+1SL	PART NAME : DB25 INTERFACE FOR RELAY				
	DESIGNER : A. TOMMASI	DATE : 03/08/2008	REVISION : 1.0	SCALE : 1:1	SIZE : A4	PAGE : 1 DI 1
ARCHIVING : 'RVVUT' SERVER, 'RILASCIATI' FOLDER	PROJECT CODE : 125	DOCUMENT CODE : SL125IN1001				

SL125IN1001

DB25 Relay Interface
 SL125IN1001
 Rev.1.1 14/11/2017
 Tommasi A.

Item	Quantity	Reference	Part
1	1	CN1	DB25FSO
2	1	CN2	CN06SA35O
3	1	CS1	CSIN0092R1
4	1	C1	1nF
5	2	C2,C3	0.1uF
6	5	D1,D2,D3,D4,D5	1N4148
7	4	FIX1,FIX2,FIX3,FIX4	FIX35
8	1	F1	RXE200
9	2	JP1,JP4	CN10PD
10	1	JP2	STM24D
11	1	JP3	STM16D
12	1	OPT1	4N25
13	1	Q1	BC547
14	1	RY1	RLYTQ2B
15	2	R1,R2	10K0
16	1	R3	1K50
17	1	R4	1M0
18	1	R5	150H0
19	1	VR1	Z18V

SL125IN2001

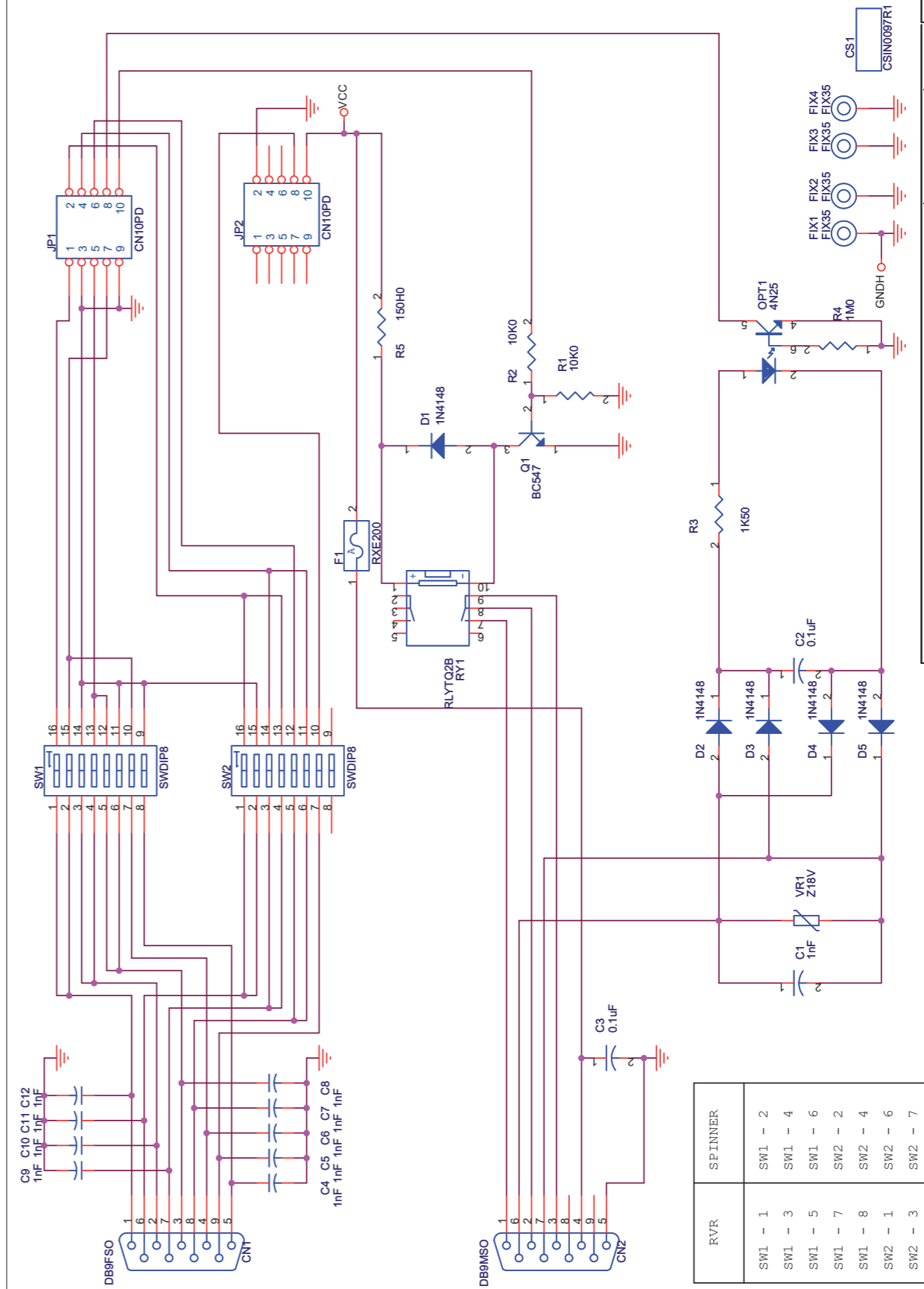
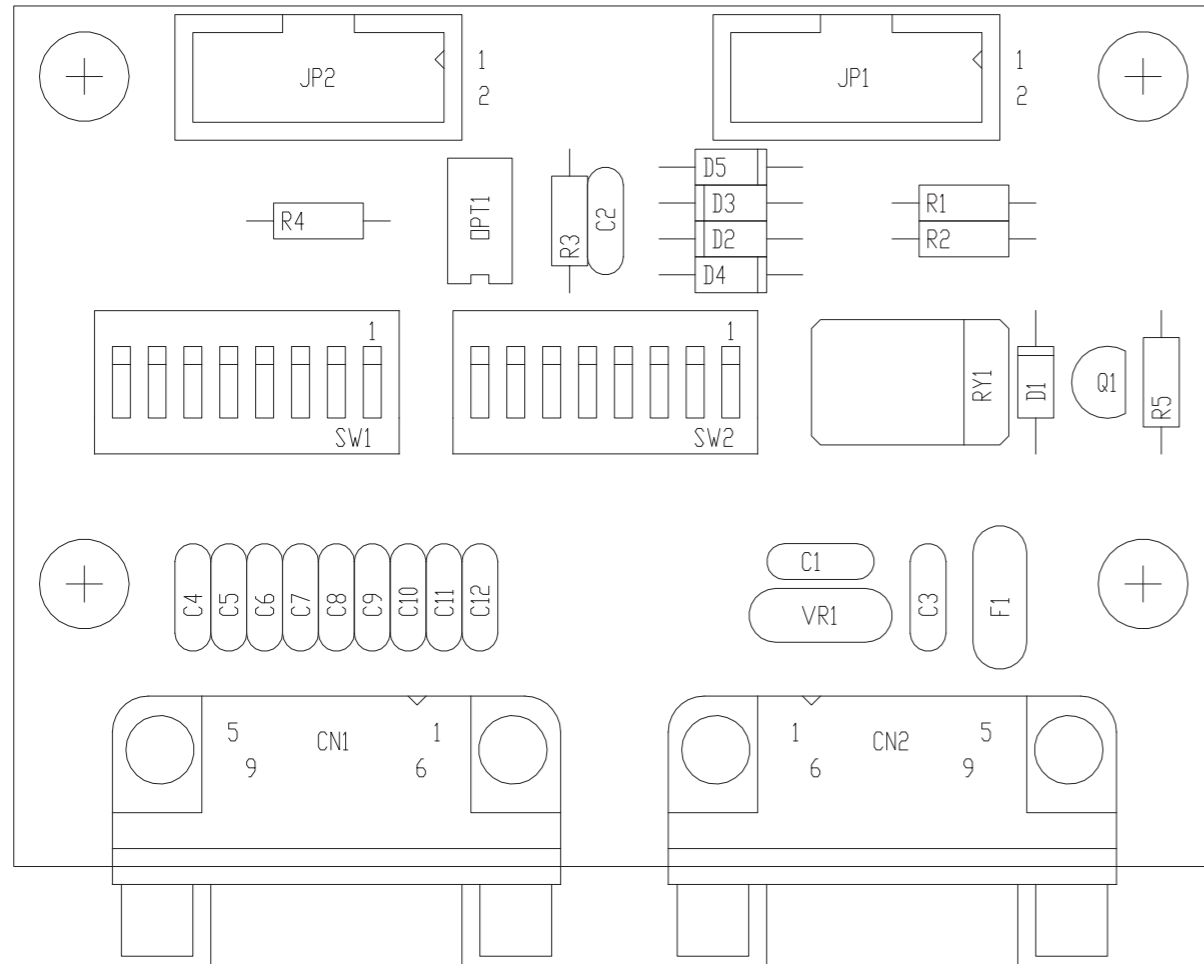

RVR	SPINNER
SW1 - 1	SW1 - 2
SW1 - 3	SW1 - 4
SW1 - 5	SW1 - 6
SW1 - 7	SW2 - 2
SW1 - 8	SW2 - 4
SW2 - 1	SW2 - 6
SW2 - 3	SW2 - 7

Project Name: Changeover
Designer: Tommasi A.
Date: 26/09/2009
File Location: \\
Folder/Filter: /
Project Code: RVR125
Description: DB9 Interf. for relay & dummy load
Revision: 1.0
Rev. No.: SL125IN2001
Page: 1 of 1
Size: A4

PRODUCT NAME: SCMLCD1+1SL
PART NAME: DB9 INTERF. FOR RELAY & DUMMY LOAD
DESIGNER: A. TOMMASI
DATE: 26/09/2009
REVISION: 1.0
SCALE: 2:1
SIZE: A4
PAGE: 1 DI 1
ARCHIVING: "RVRUT" SERVER, "RILASCIATI" FOLDER
PROJECT CODE: 125
DOCUMENT CODE: SL125IN2001

SL125IN2001

DB9 Interf. for relay & dummy load
 Revised: Tuesday, September 26, 2006
 SL125IN2001 Revision: 1.0
 Changeover
 RVR125
 Tommasi A.

Item	Quantity	Reference	Part	Description
1	1	CN1	DB9FSO	Connettore DB9 femm. cs 90°
2	1	CN2	DB9MSO	Connettore DB9 mas. cs 90°
3	1	CS1	CSIN0097R1	Circuito stampato
4	10	C1,C4,C5,C6,C7,C8,C9,C10, C11,C12	1nF	Cond. ceramico p 5mm
5	2	C2,C3	0.1uF	Cond. ceramico p 5mm
6	5	D1,D2,D3,D4,D5	1N4148	Diodo in vetro DO35
7	4	FIX1,FIX2,FIX3,FIX4	FIX35	Foro fissaggio 3.5mm
8	1	F1	RXE200	Fusibile autorip. 7mm
9	2	JP1,JP2	CN10PD	Connettore 10 poli Flat cs
10	1	OPT1	4N25	Optoisolatore DIP6
11	1	Q1	BC547	Trans. NPN TO92
12	1	RY1	RLYTQ2B	Rele' TQ2
13	2	R1,R2	10K0	Res. 1/4W 1%
14	1	R3	1K50	Res. 1/4W 1%
15	1	R4	1M0	Res. 1/4W 1%
16	1	R5	150H0	Res. 1/4W 1%
17	2	SW1,SW2	SWDIP8	Dip switch 8 vie
18	1	VR1	Z18V	Varistor