

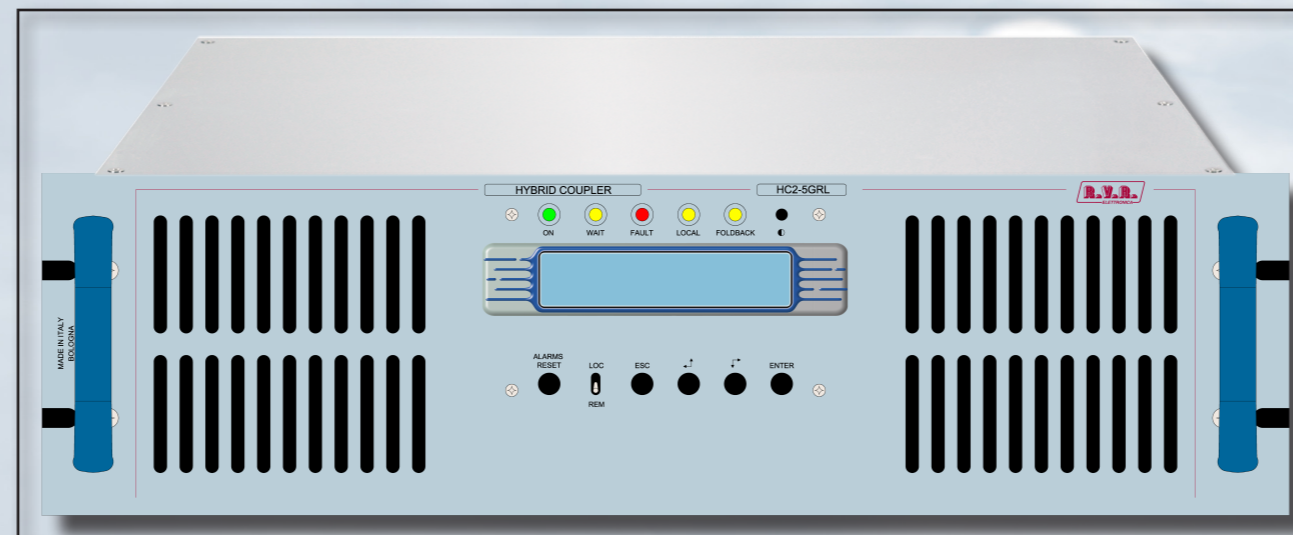

HC2-5GRL

TECHNICAL ANNEX VOLUME 2



R.V.R. Elettronica
Via del Fonditore, 2 / 2c
Zona Industriale Roveri · 40138 Bologna · Italy
Phone: +39 051 6010506 · Fax: +39 051 6011104
e-mail: info@rvr.it · web: http://www.rvr.it

Member of CISQ Federation



CERTIFIED MANAGEMENT SYSTEM
ISO 9001



The RVR Logo, and others referenced RVR products and services are trademarks of RVR Elettronica in Italy, other countries or both. RVR © 1998 all rights reserved.
All other trademarks, trade names or logos used are property of their respective owners.

Manufactured by R.V.R. ELETTRONICA Italy



Appendix A Piani di montaggio, schemi elettrici, liste componenti / *Component layouts, schematics, bills of material*

Questa parte del manuale contiene i dettagli tecnici riguardanti la costruzione delle singole schede componenti il HC2-5GRL. L'appendice è composta dalle seguenti sezioni:

This part of the manual contains the technical details about the different Cards of the HC2-5GRL. This appendix is composed of the following sections:

Description	RVR Code	Vers.	Page
Wiring Diagram	KKCAB021A	1.3	1
Phase Shifter Card	SLPHSHHC2-01	1.0	6
Power Splitter Card	SLSPLTHC2-01	1.0	8
Power Combiner Card	SLCMB1HC2-01	1.1	11
CPU Card	PROTPJ-HCLCD	3.1	14
CPU Adapter Card	SLADPCNP RTPJ	2.1	21
Power Supply	PSSWEPP10024	1.0	28
PROT-F Interface Add-On Card	SLIN0411R02V01	1.2	24
Meter Card	SL042MT1001	1.1	27

Description	Spare Parts
Fan	VTL9GL1224J
CPU panel & Display	SP-PAN021A
Switching power supply	PSSWEPP10024
Power Meter Section	SP-MTR021A

Document History

Date	Version	Reason	Code	Editor
29/11/2019	1.0	First Release	/	J.H. Berti

KKCAB021A

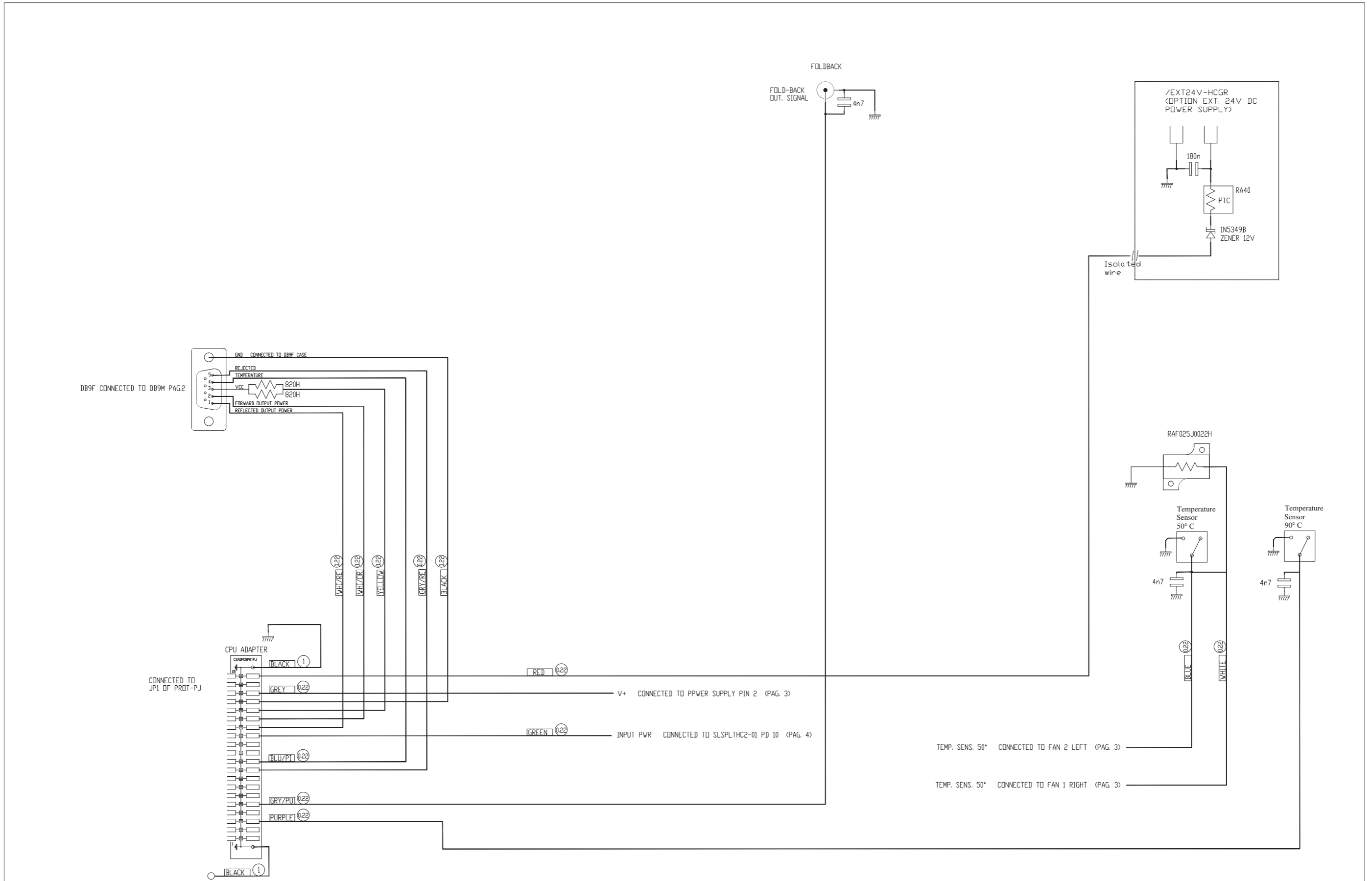

	PRODUCT NAME : HC2-GRL	PART NAME : WIRING DIAGRAM			
	DESIGNER : M. UCELLI; G. DE DONNO	DATE 31/07/18	REVISION 1.3	SCALE 1:1	SIZE A3
ARCHIVING : 'RVRT' SERVER, 'RILASCIATI' FOLDER	PROJECT CODE : 021	DOCUMENT CODE : KKCAB021A			

COMBINER SECTION

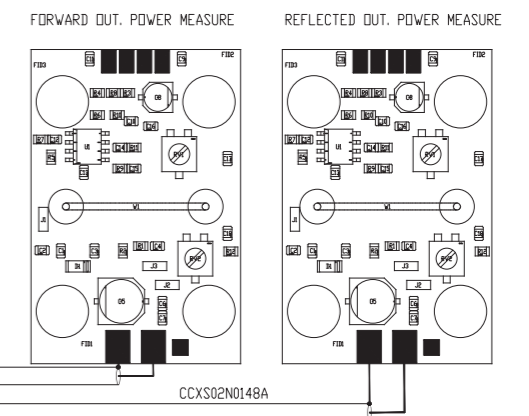
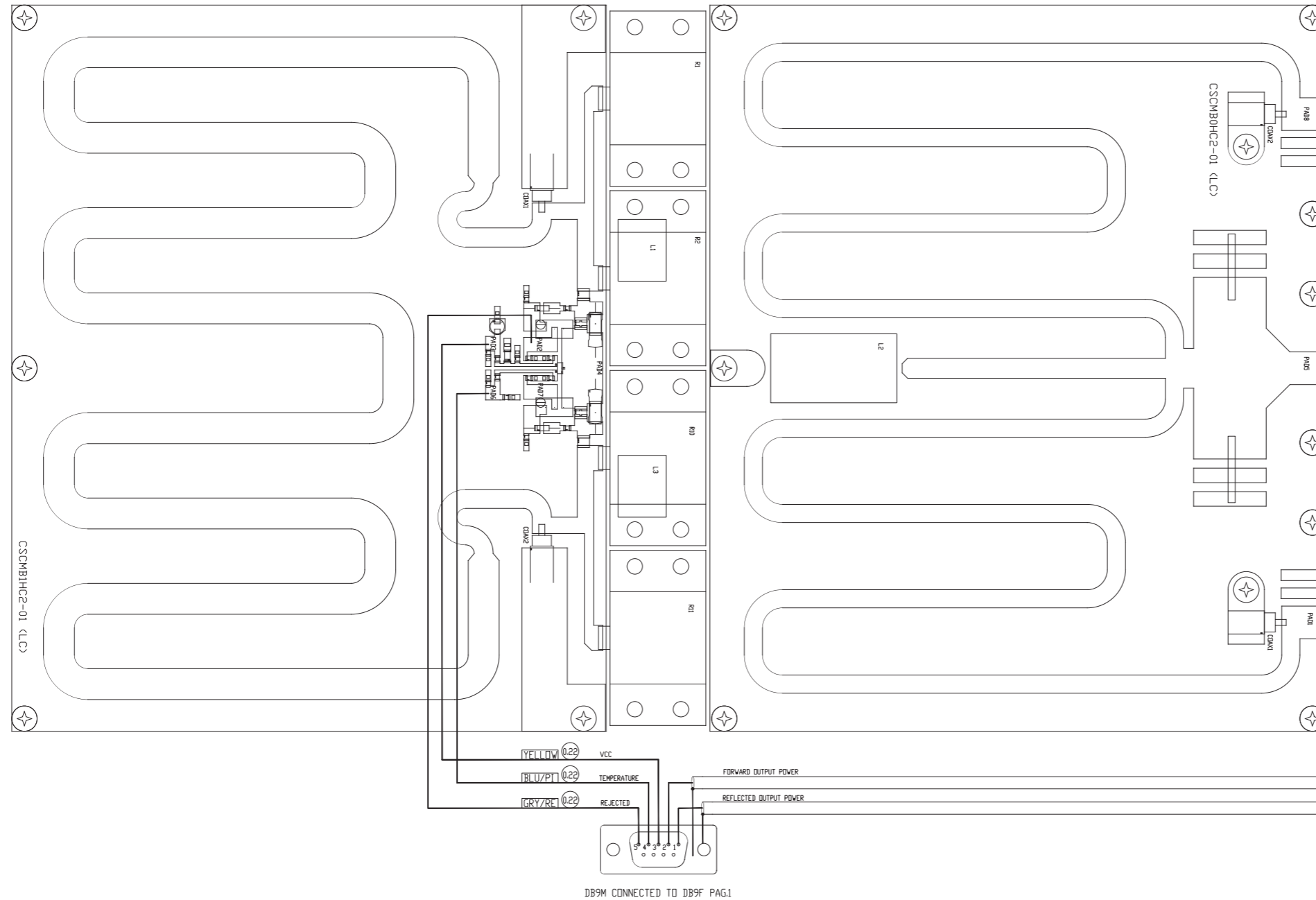

	PRODUCT NAME : HC2-GRL	PART NAME : WIRING DIAGRAM
	DESIGNER : M. UCELLI; G. DE DONNO	DATE 31/07/18 REVISION 1.3 SCALE 1:1 SIZE A3 PAGE : 2 DI 5
ARCHIVING : "RVRUT" SERVER, "RILASCIATI" FOLDER	PROJECT CODE : 021	DOCUMENT CODE : KKCAB021A

KKCAB021A

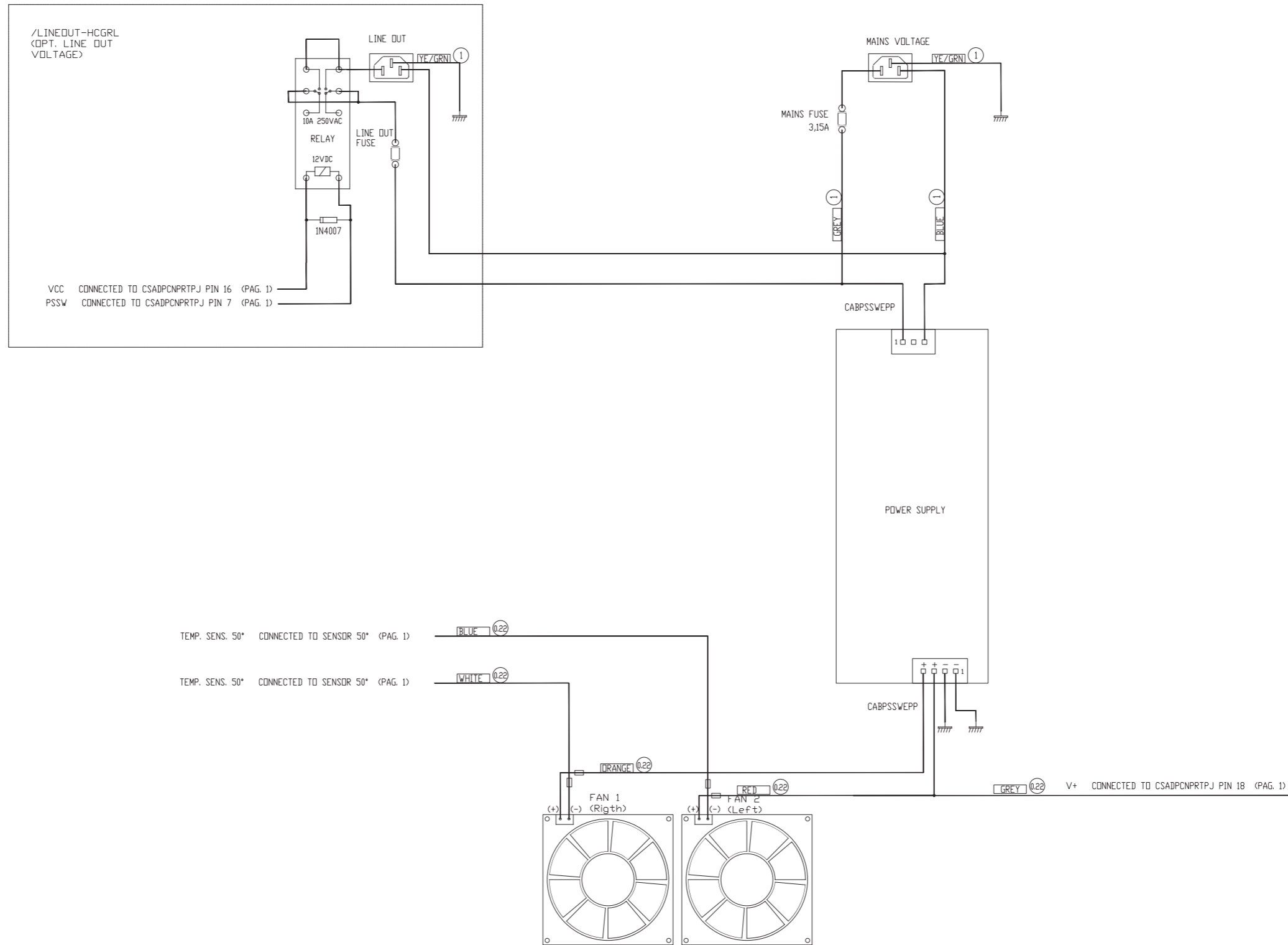

	PRODUCT NAME : HC2-GRL	PART NAME : WIRING DIAGRAM				
	DESIGNER : M. UCELLI; G. DE DONNO	DATE 31/07/18	REVISION 1.3	SCALE 1:1	SIZE A3	PAGE : 3 DI 5
ARCHIVING : 'RVRUT' SERVER, 'RILASCIATI' FOLDER		PROJECT CODE : 021	DOCUMENT CODE : KKCAB021A			

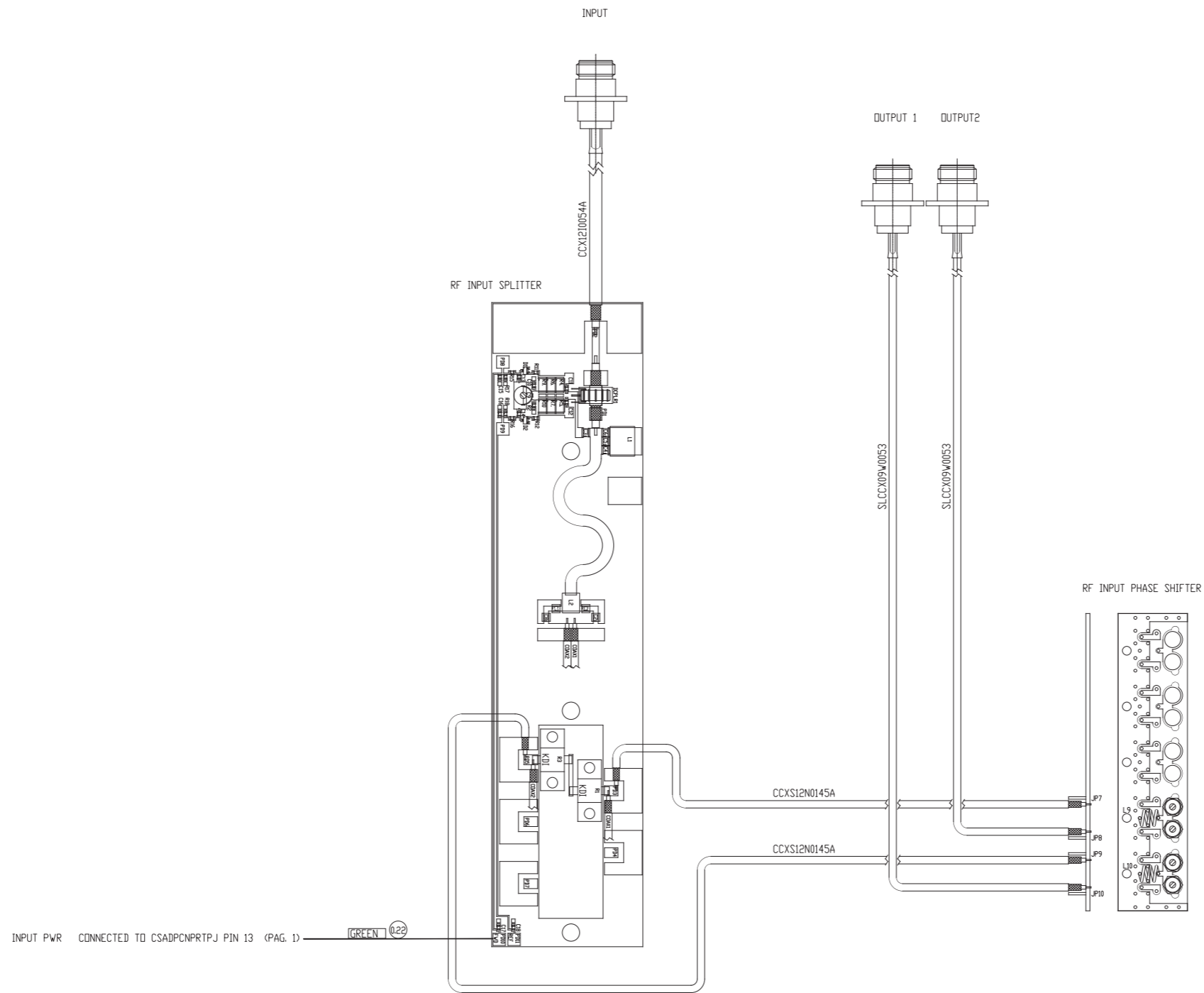

	PRODUCT NAME : HC2-GRL	PART NAME : WIRING DIAGRAM			
	DESIGNER : M. UCELLI; G. DE DONNO	DATE 31/07/18	REVISION 1.3	SCALE 1:1	SIZE A3
ARCHIVING : "RVRUT" SERVER, "RILASCIATI" FOLDER		PROJECT CODE : 021	DOCUMENT CODE : KKCAB021A		

KKCAB021A

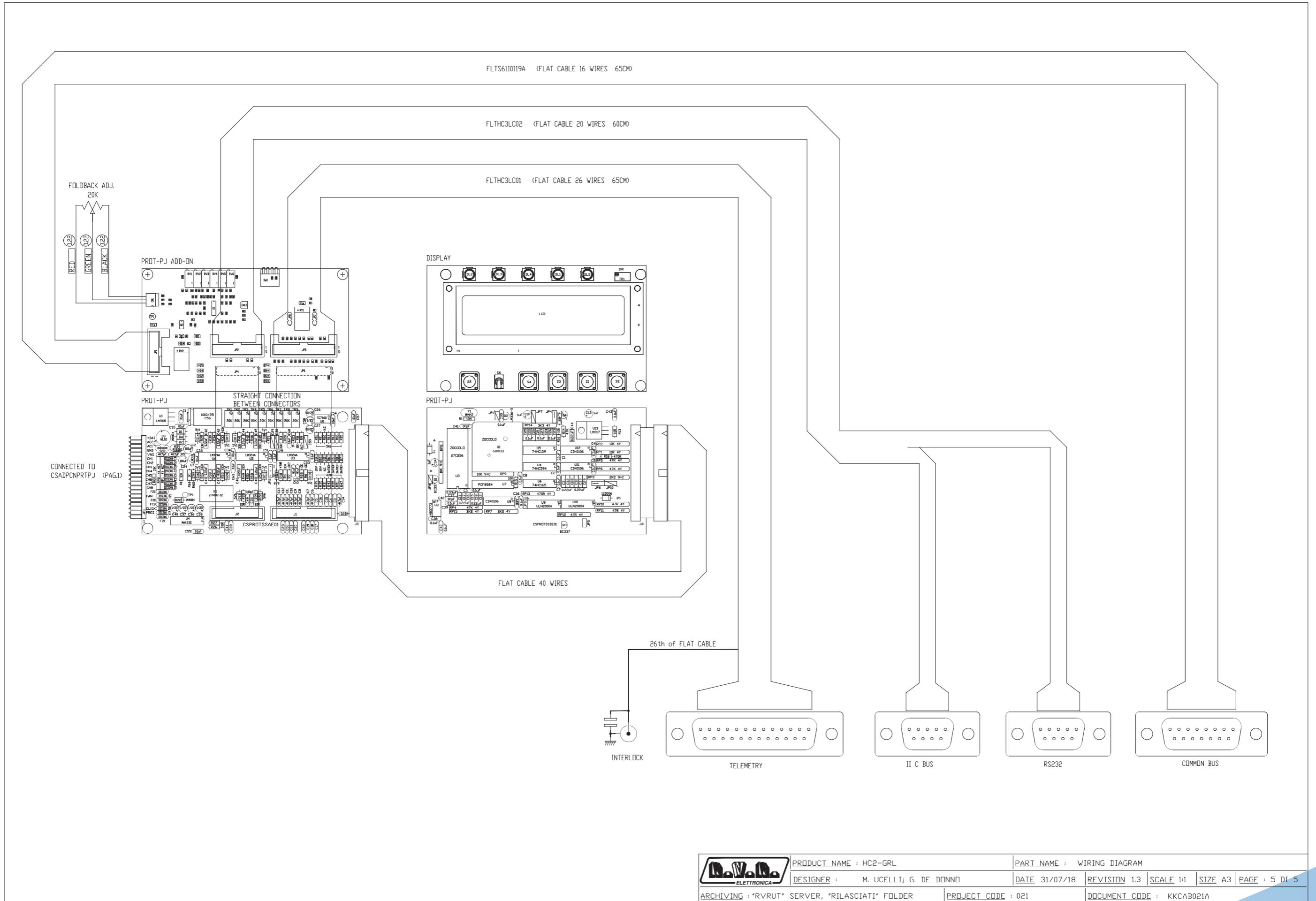

	PRODUCT NAME : HC2-GRL	PART NAME : WIRING DIAGRAM			
	DESIGNER : M. UCELLI; G. DE DONNO	DATE 31/07/18	REVISION 1.3	SCALE 1:1	SIZE A3
ARCHIVING : 'RVUT' SERVER, 'RILASCIATI' FOLDER	PROJECT CODE : 021	DOCUMENT CODE : KKCAB021A			

SLPHSHHC2-01

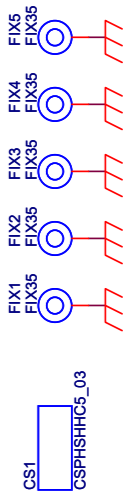
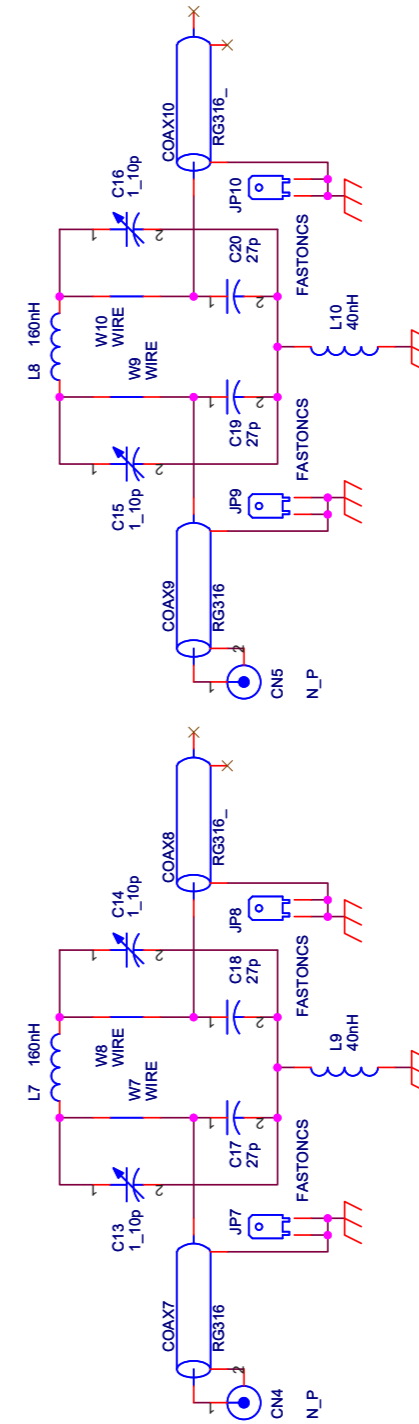
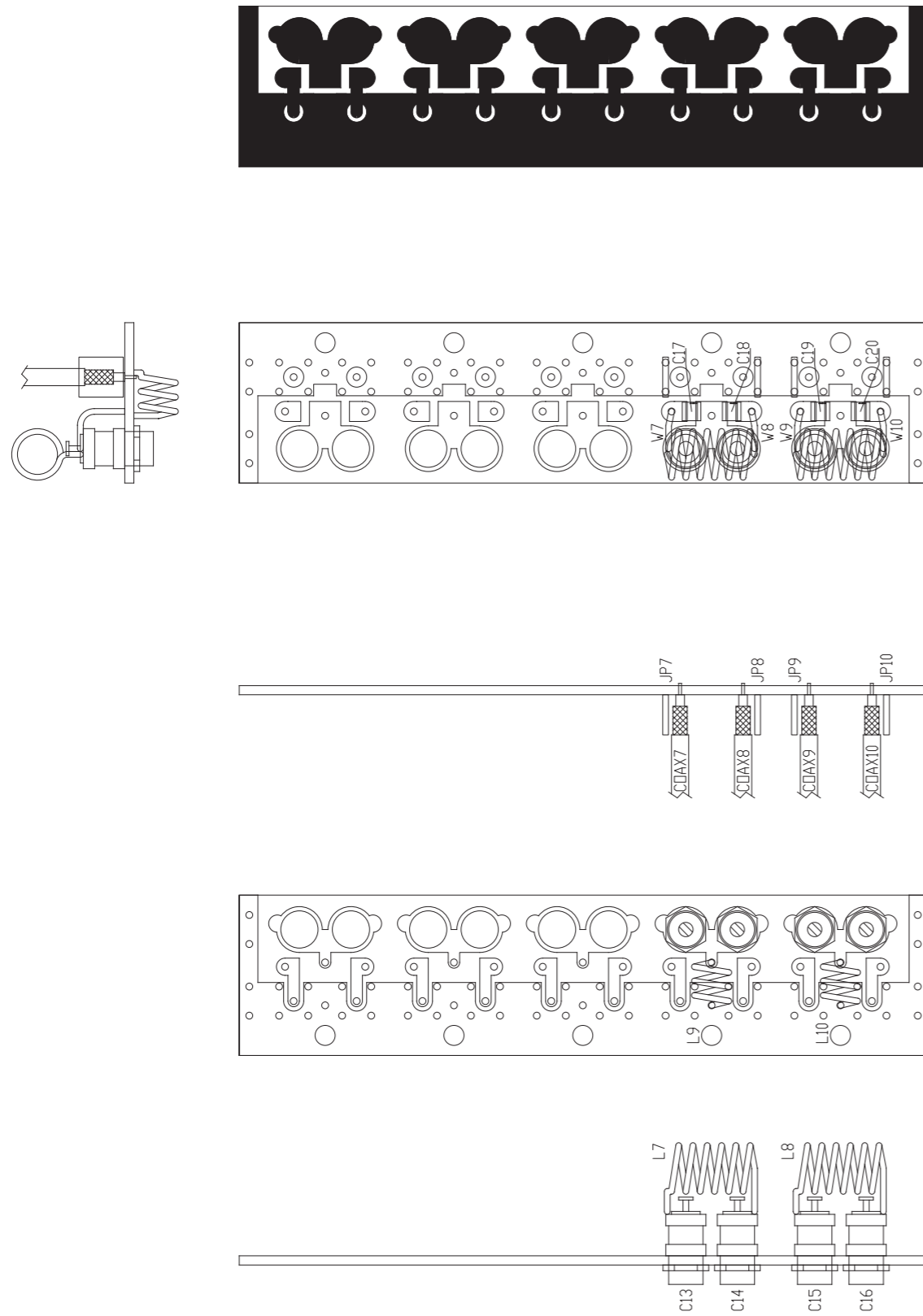

Description: Phase Shifter for HC2/LCD	
Designer: Ucelli / De Donno	Size: A4
Part No.: SLPHSHHC2-01	Page: 1 of 1
	Date: 07/06/2013
	Rev. 1.0

	PRODUCT NAME : HC2/2	PART NAME : Phase shifter Card			
	DESIGNER : UCELLI / DE DONNO	DATE : 07/06/13	REVISION : 1.0	SCALE : 1:1	SIZE : A4
ARCHIVING : *RVRUT* SERVER, *RILASCIATI* FOLDER	PROJECT CODE : _019	DOCUMENT CODE : SLPHSHHC2-01			

SLPHSHHC2-01

Phase Shifter for HC2/2 LCD
 SLPHSHHC2-01
 Revision: 1.0
 HC2/2
 Ucelli / De Donno
 07/06/2013

Item	Quantity	Reference	Part	Description
1	2	CN4,CN5	N_P	N panel connector for RG316 cable
2	2	COAX7,COAX9	RG316	Coax cable
3	2	COAX8,COAX10	RG316	Coax cable 50H RG316 (595mm)
4	1	CS1	CSPHSHHC5_03	Printed circuit board
5	4	C13,C14,C15,C16	1_10p	Air static VAR compensator Tekelec 6mm
6	4	C17,C18,C19,C20	27p	SMD capacitor 1212 HQ
7	5	FIX1,FIX2,FIX3,FIX4,FIX5	FIX35	Fixing hole 3.5mm
8	4	JP7,JP8,JP9,JP10	FASTONCS	Printed circuit faston p. 5.08
9	2	L7,L8	160nH	Inductor 6 Coils silver plated copper wire D.1 wound on D.7 length 15
10	2	L9,L10	40nH	Inductor 3 Coils silver plated copper wire D.1 wound on D.5 length 6
11	4	W7,W8,W9,W10	WIRE	Solder wire

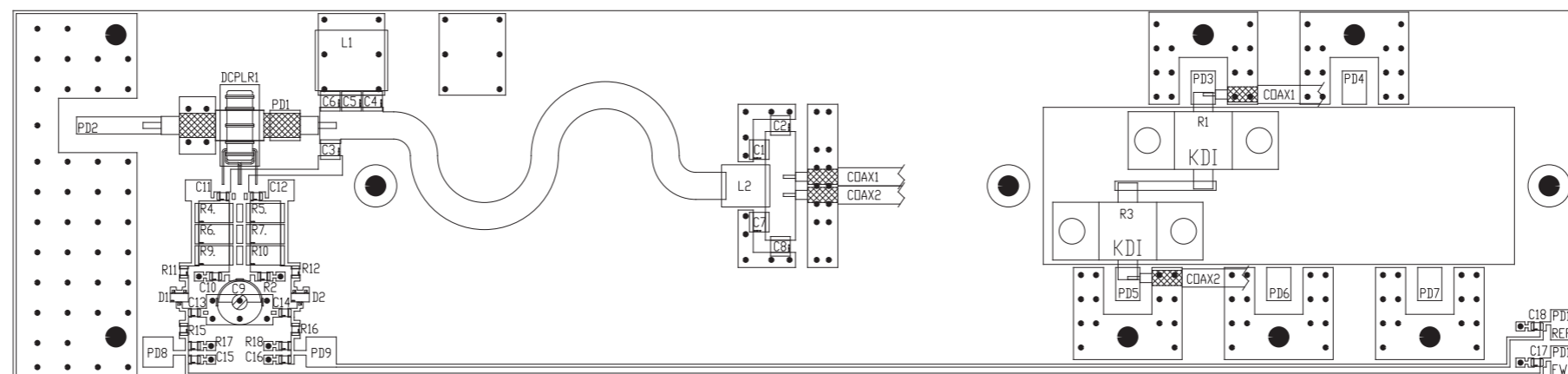

	PRODUCT NAME : HC2-4	PART NAME : SPLITTER CARD
	DESIGNER : M. UCELLI	DATE 19/04/04 REVIS. : 1.0 SCALE 1:1 SIZE A3 PAGE :1 DI 1
ARCHIVING : 'RVRUT' SERVER, 'RILASCIATI' FOLDER PROJECT CODE : 017		DOCUMENT CODE : SLSPLTHC2-01

SLSPLTHC2-01

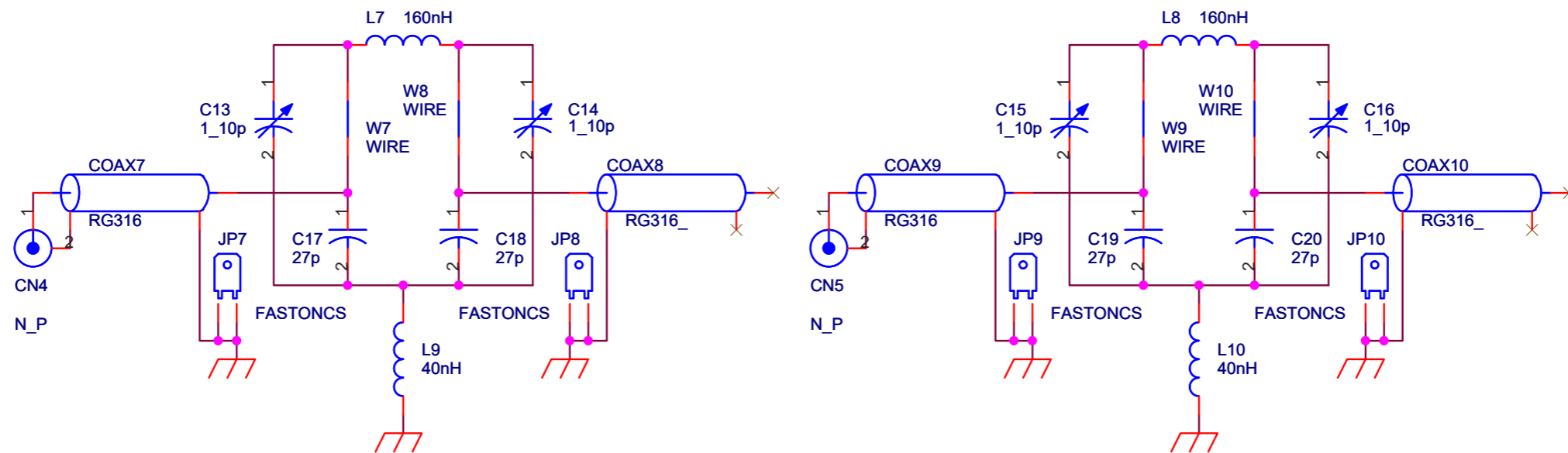

CS1
CSPHSHHC5_03

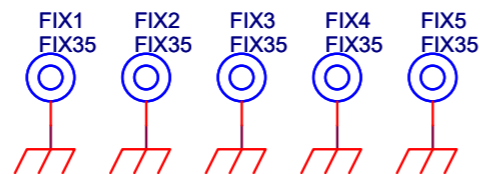

Description: Phase Shifter for HC2/2 LCD		
Designer: Ucelli \ De Donno	Size: A4	Page: 1 of 1
Part No.: SLPHSHHC2-01	Rev. 1.0	Date: 07/06/2013



SLSPLTHC2-01

Phase Shifter for HC2/2 LCD
 SLPHSHHC2-01
 Revision: 1.0
 HC2/2
 Ucelli / De Donno
 07/06/2013

Item	Quantity	Reference	Part	Description
1	2	CN4,CN5	N_P	N panel connector for RG316 cable
2	2	COAX7,COAX9	RG316	Coax cable
3	2	COAX8,COAX10	RG316_	Coax cable 50H RG316 (595mm)
4	1	CS1	CSPHSHHC5_03	Printed circuit board
5	4	C13,C14,C15,C16	1_10p	Air static VAR compensator Tekelec 6mm
6	4	C17,C18,C19,C20	27p	SMD capacitor 1212 HQ
7	5	FIX1,FIX2,FIX3,FIX4,FIX5	FIX35	Fixing hole 3.5mm
8	4	JP7,JP8,JP9,JP10	FASTONCS	Printed circuit faston p. 5.08
9	2	L7,L8	160nH	Inductor 6 Coils silver plated copper wire D.1 wound on D.7 length 15
10	2	L9,L10	40nH	Inductor 3 Coils silver plated copper wire D.1 wound on D.5 length 6
11	4	W7,W8,W9,W10	WIRE	Solder wire

SLCMB1HC2-01

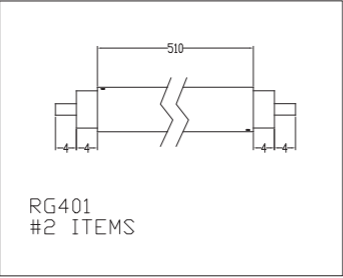
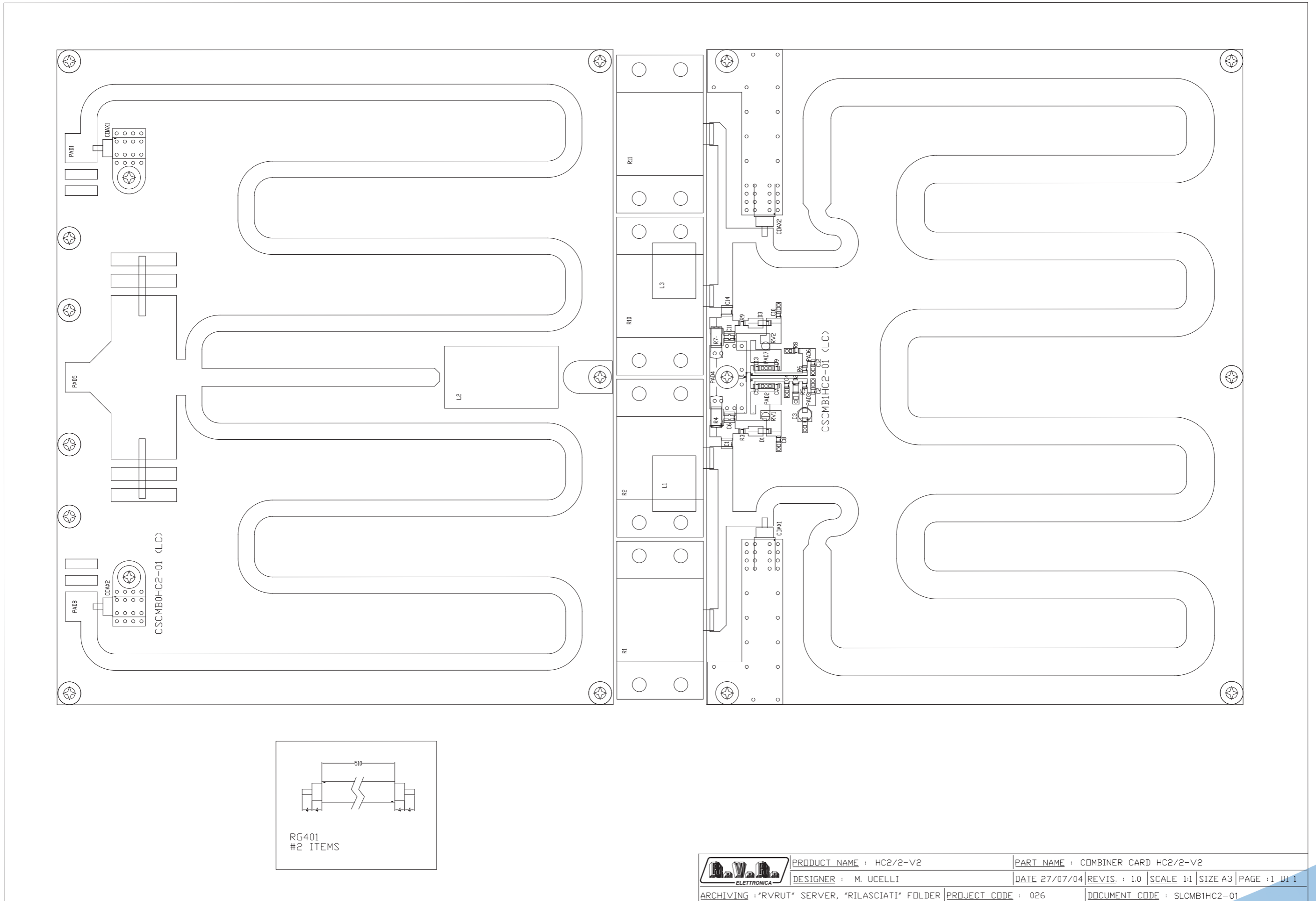

PRODUCT NAME : HC2/2-V2	PART NAME : COMBINER CARD HC2/2-V2
DESIGNER : M. UCELLI	DATE 27/07/04 REVIS. : 1.0 SCALE 1:1 SIZE A3 PAGE : 1 DI 1
ARCHIVING : 'RVRUT' SERVER, 'RILASCIATI' FOLDER PROJECT CODE : 026	DOCUMENT CODE : SLCMB1HC2-01

SLCMB1HC2-01

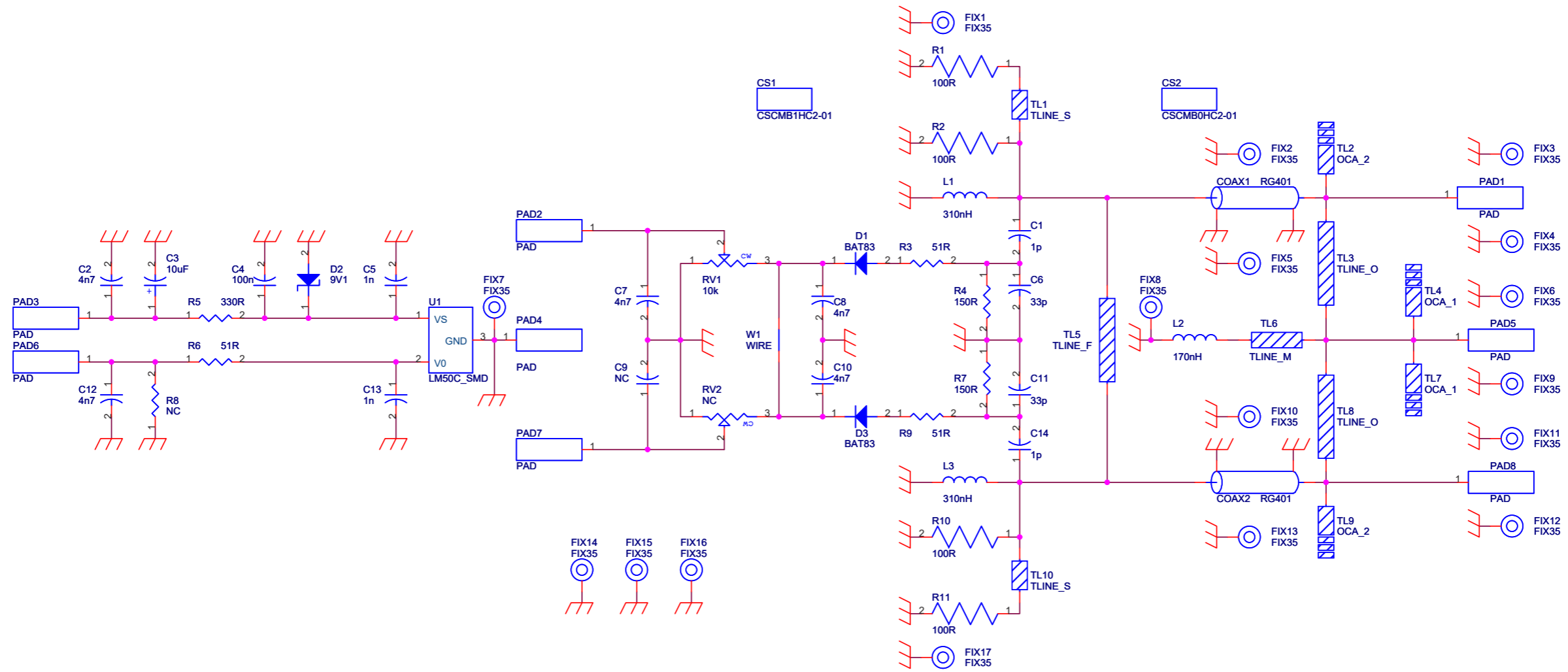

Description: HC2-2 Output Combiner		
Designer: Mauro Ucelli	Size: A3	Page: 1 of 1
Part No.: SLCMB1HC2-01	Rev.: 1.1	Date: 22/03/05



SLCMB1HC2-01

HC2-2 Output Combiner
 SLCMB1HC2-01
 Revision: 1.1
 HC2/2-V2
 026
 Mauro Ucelli
 22/03/05

Item	Quantity	Reference	Part	Description
1	2	COAX1,COAX2	RG401	Coax cable
2	1	CS1	CSCMB1HC2-01	Printed circuit board
3	1	CS2	CSCMB0HC2-01	Printed circuit board
4	2	C1,C14	1p	SMD capacitor 1212 HQ
5	5	C2,C7,C8,C10,C12	4n7	SMD capacitor 0805
6	1	C3	10uF	SMD electrolytic capacitor d. 5mm
7	1	C4	100n	SMD capacitor 0805
8	2	C13,C5	1n	SMD capacitor 0805
9	2	C6,C11	33p	SMD capacitor 1212 HQ
10	1	C9	NC	SMD capacitor 0805
11	2	D1,D3	BAT83	Glass diode DO35
12	1	D2	9V1	MINIMELF SMD Zener Diode
13	17	FIX1, FIX2, FIX3, FIX4, FIX5, FIX6, FIX7, FIX8, FIX9, FIX10, FIX11, FIX12, FIX13, FIX14, FIX15, FIX16, FIX17	FIX35	Fixing hole 3.5mm
14	2	L1,L3	310nH	Cylindrical inductor
15	1	L2	170nH	Cylindrical inductor
16	8	PAD1, PAD2, PAD3, PAD4, PAD5, PAD6, PAD7, PAD8	PAD	
17	1	RV1	10k	Trimmer Rg V 3296W
18	1	RV2	NC	Trimmer Rg V 3296W
19	4	R1,R2,R10,R11	100R	KDI resistor 4 fix
20	3	R3,R6,R9	51R	SMD resistor 0805
21	2	R4,R7	150R	Resistor 2W
22	1	R5	330R	SMD resistor 0805
23	1	R8	NC	SMD resistor 0805
24	2	TL10, TL1	TLINE_S	Printed circuit strip line
25	2	TL2, TL9	OCA_2	Printed circuit strip line
26	2	TL3, TL8	TLINE_O	Printed circuit strip line
27	2	TL4, TL7	OCA_1	Printed circuit strip line
28	1	TL5	TLINE_F	Printed circuit strip line
29	1	TL6	TLINE_M	Printed circuit strip line
30	1	U1	LM50C_SMD	Temperature sensor
31	1	W1	WIRE	Solder wire

PROTPJ-HCLCD

ARCHIVING : "RVRUT" SERVER, "RILASCIATI" FOLDER | PRODUCT CODE : 014 | PART NAME : Analogic Section Component Layout | DOCUMENT CODE : PROTPJ-HCLCD

DESIGNER : GP - Rev: J. Berti | DATE : 14/03/07 | REVISION : 3.1 | SCALE : 1:1 | SIZE : A4 | PAGE : 1 DI 1

PRODUCT NAME : HCS-10

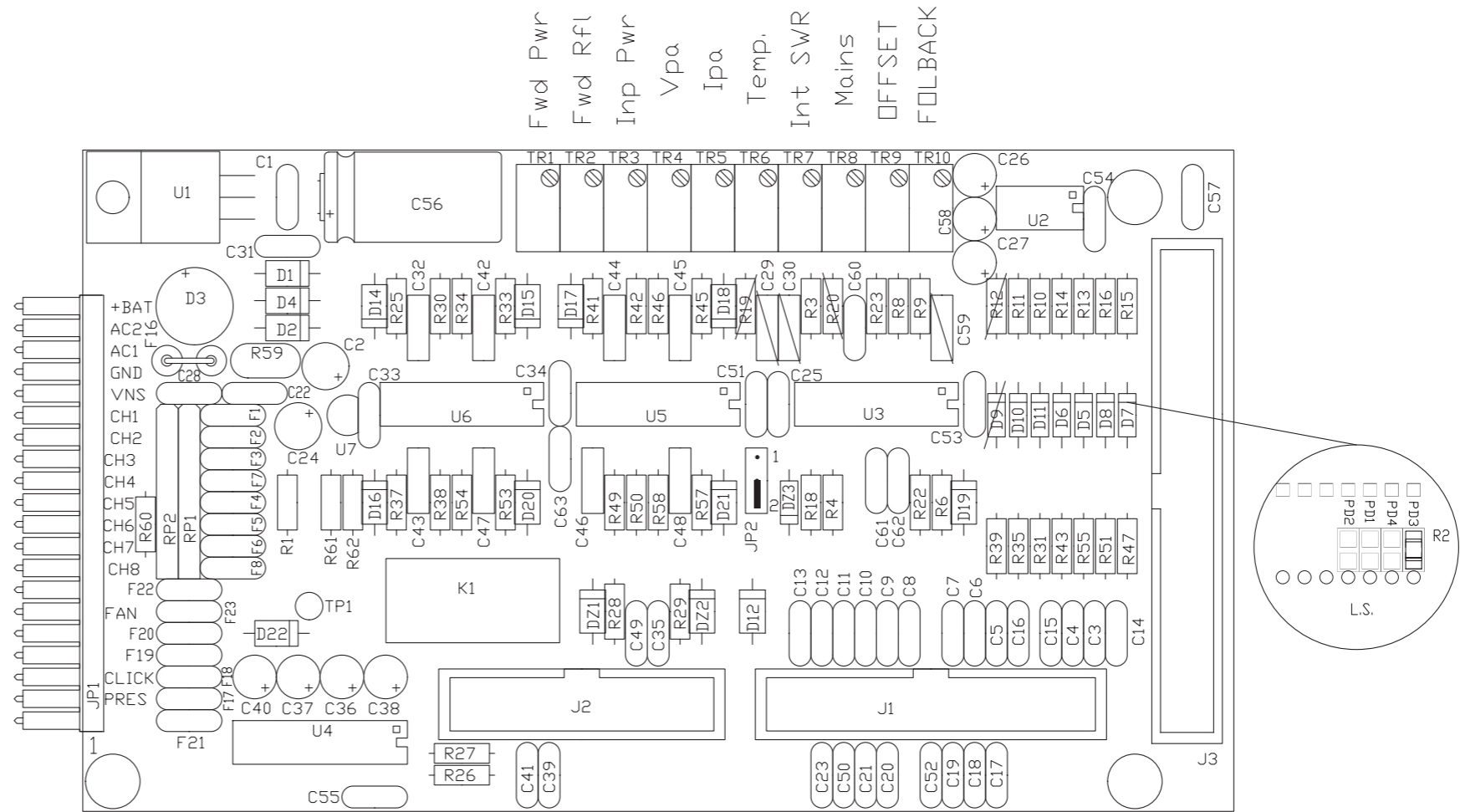

PROTPJ-HCLCD

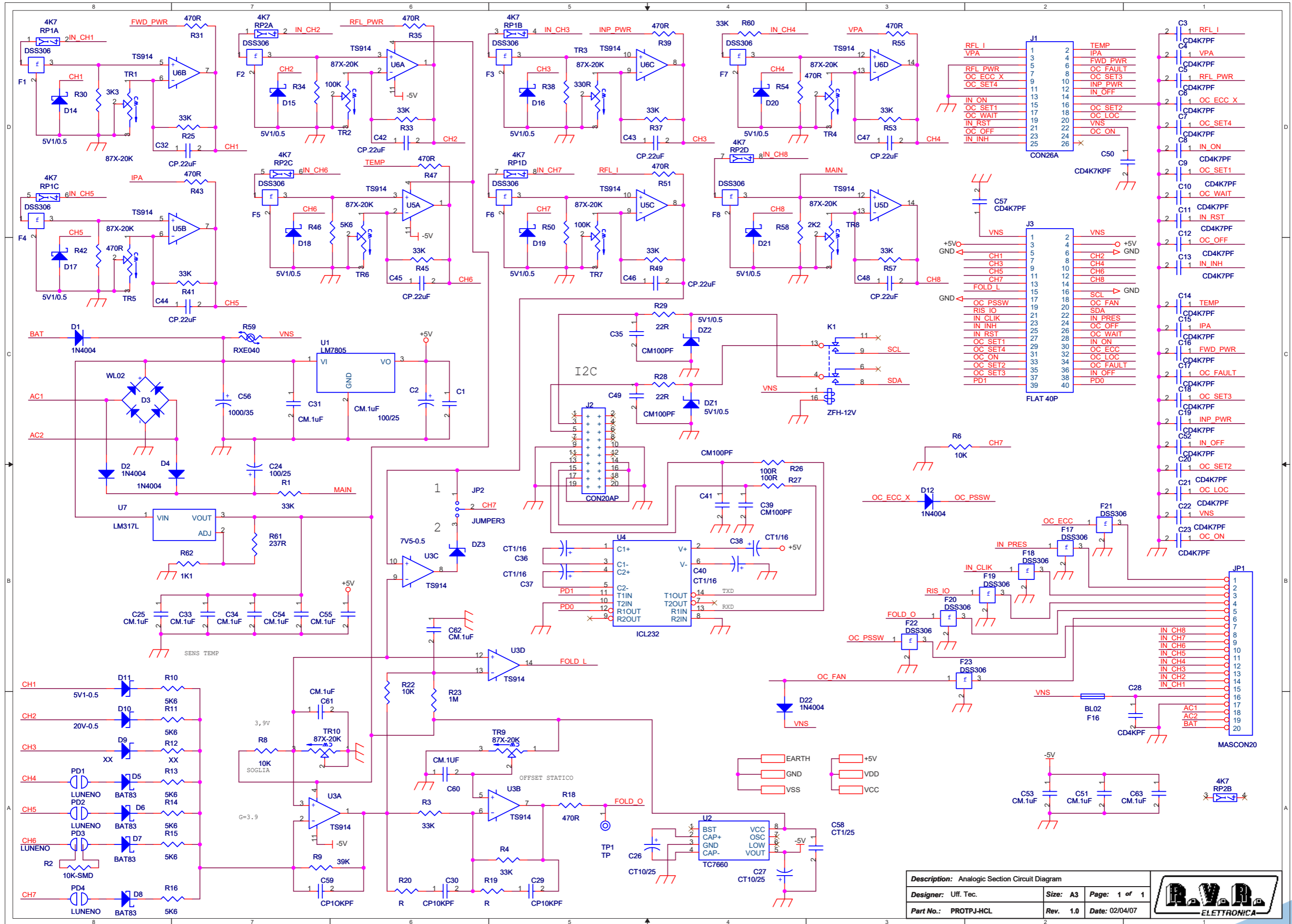

Description: Analogic Section Circuit Diagram		
Designer: Uff. Tec.	Size: A3	Page: 1 of 1
Part No.: PROTPJ-HCL	Rev. 1.0	Date: 02/04/07



PROTPJ-HCLCD

Revised: Thursday, January 08, 2009
Revision:

Item	Quantity	Reference	Part
1	13	C1, C25, C31, C33, C34, C51, C53, C54, C55, C60, C61, C62, C63	CM.1uF
2	2	C2, C24	100/25
3	23	C3, C4, C5, C6, C7, C8, C9, C10, C11, C12, C13, C14, C15, C16, C17, C18, C19, C20, C21, C22, C23, C52, C57	CD4K7PF
4	2	C26, C27	CT10/25
5	1	C28	CD4KPF
6	2	C29, C30	CP10KPF
7	8	C32, C42, C43, C44, C45, C46, C47, C48	CP.22uF
8	4	C35, C39, C41, C49	CM100PF
9	4	C36, C37, C38, C40	CT1/16
10	1	C50	CD4K7KPF
11	1	C56	1000/35
12	1	C58	CT1/25
13	1	C59	CP10KPF
14	10	DZ1, DZ2, D14, D15, D16, D17, D18, D19, D20, D21	5V1/0.5
15	1	DZ3	7V5-0.5
16	5	D1, D2, D4, D12, D22	1N4004
17	1	D3	WL02
18	4	D5, D6, D7, D8	BAT83
19	2	D9, R12	XX
20	1	D10	20V-0.5
21	1	D11	5V1-0.5
22	15	F1, F2, F3, F4, F5, F6, F7, F8, F17, F18, F19, F20, F21, F22, F23	DSS306
23	1	F16	BL02
24	1	JP1	MASCON20
25	1	JP2	JUMPER3
26	1	J1	CON26A
27	1	J2	CON20AP
28	1	J3	FLAT 40P
29	1	K1	ZFH-12V
30	4	PD1, PD2, PD3, PD4	LUNENO
31	2	RP1, RP2	4K7
32	12	R1, R3, R4, R25, R33, R37, R41, R45, R49, R53, R57, R60	33K
33	1	R2	10K-SMD
34	3	R6, R8, R22	10K
35	1	R9	39K
36	7	R10, R11, R13, R14, R15, R16, R46	5K6
37	10	R18, R31, R35, R39, R42, R43, R47, R51, R54, R55	470R
38	2	R19, R20	R
39	1	R23	1M
40	2	R26, R27	100R
41	2	R28, R29	22R
42	1	R30	3K3
43	2	R34, R50	100K
44	1	R38	330R
45	1	R58	2K2
46	1	R59	RXE040
47	1	R61	237R
48	1	R62	1K1
49	1	TP1	TP
50	10	TR1, TR2, TR3, TR4, TR5, TR6, TR7, TR8, TR9, TR10	87X-20K
51	1	U1	LM7805
52	1	U2	TC7660
53	3	U3, U5, U6	TS914
54	1	U4	ICL232
55	1	U7	LM317L

Revised: Thursday, January 08, 2009
Revision:

Item	Quantity	Reference	Part
1	13	C1, C25, C31, C33, C34, C51, C53, C54, C55, C60, C61, C62, C63	CM.1uF
2	2	C2, C24	100/25
3	23	C3, C4, C5, C6, C7, C8, C9, C10, C11, C12, C13, C14, C15, C16, C17, C18, C19, C20, C21, C22, C23, C52, C57	CD4K7PF
4	2	C26, C27	CT10/25
5	1	C28	CD4KPF
6	2	C29, C30	CP10KPF
7	8	C32, C42, C43, C44, C45, C46, C47, C48	CP.22uF
8	4	C35, C39, C41, C49	CM100PF
9	4	C36, C37, C38, C40	CT1/16
10	1	C50	CD4K7KPF
11	1	C56	1000/35
12	1	C58	CT1/25
13	1	C59	CP10KPF
14	10	DZ1, DZ2, D14, D15, D16, D17, D18, D19, D20, D21	5V1/0.5
15	1	DZ3	7V5-0.5
16	5	D1, D2, D4, D12, D22	1N4004
17	1	D3	WL02
18	4	D5, D6, D7, D8	BAT83
19	2	D9, R12	XX
20	1	D10	20V-0.5
21	1	D11	5V1-0.5
22	15	F1, F2, F3, F4, F5, F6, F7, F8, F17, F18, F19, F20, F21, F22, F23	DSS306
23	1	F16	BL02
24	1	JP1	MASCON20
25	1	JP2	JUMPER3
26	1	J1	CON26A
27	1	J2	CON20AP
28	1	J3	FLAT 40P
29	1	K1	ZFH-12V
30	4	PD1, PD2, PD3, PD4	LUNENO
31	2	RP1, RP2	4K7
32	12	R1, R3, R4, R25, R33, R37, R41, R45, R49, R53, R57, R60	33K
33	1	R2	10K-SMD
34	3	R6, R8, R22	10K
35	1	R9	39K
36	7	R10, R11, R13, R14, R15, R16, R46	5K6
37	10	R18, R31, R35, R39, R42, R43, R47, R51, R54, R55	470R
38	2	R19, R20	R
39	1	R23	1M
40	2	R26, R27	100R
41	2	R28, R29	22R
42	1	R30	3K3
43	2	R34, R50	100K
44	1	R38	330R
45	1	R58	2K2
46	1	R59	RXE040
47	1	R61	237R
48	1	R62	1K1
49	1	TP1	TP
50	10	TR1, TR2, TR3, TR4, TR5, TR6, TR7, TR8, TR9, TR10	87X-20K
51	1	U1	LM7805
52	1	U2	TC7660
53	3	U3, U5, U6	TS914
54	1	U4	ICL232
55	1	U7	LM317L

PROTPJ-HCLCD

ARCHIVING : "RVVUT" SERVER, "RILASCIATI" FOLDER

PRODUCT NAME : HCS-10

DESIGNER : GP - Rev: J. Berti

PART NAME : LCD Alarms Card Layout

DATE : 30/10/08

REVISION : 1.1

SCALE : 1:1

SIZE : A4

PAGE : 1 DI 1

PROJECT CODE : 014

DOCUMENT CODE : PROTPJ-HCLCD

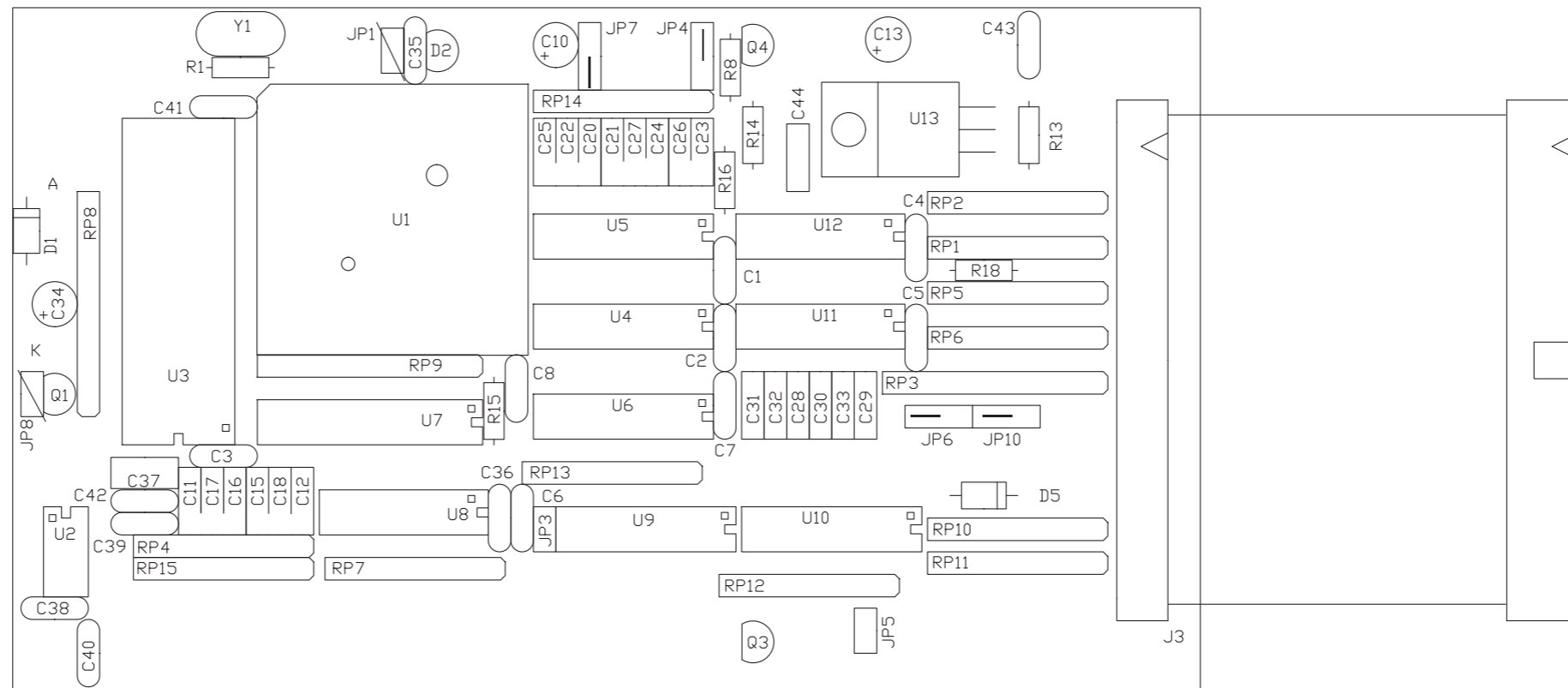

PROTPJ-HCLCD

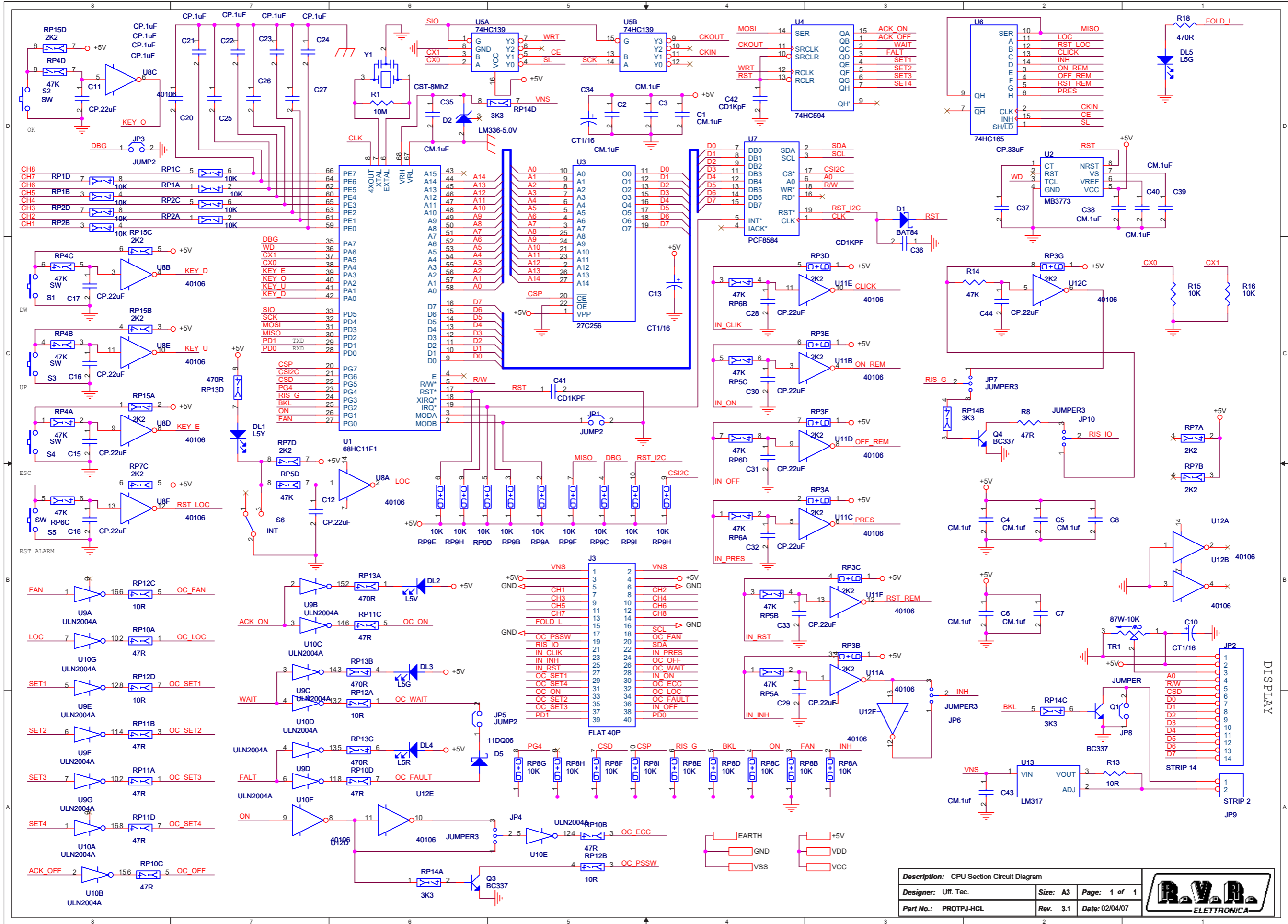

Description: CPU Section Circuit Diagram		
Designer: Uff. Tec.	Size: A3	Page: 1 of 1
Part No.: PROTPJ-HCL	Rev. 3.1	Date: 02/04/07



PROTPJ-HCLCD

Revised: Thursday, January 08, 2009
Revision:

Item	Quantity	Reference	Part
1	13	C1, C2, C3, C4, C5, C6, C7, C8, C35, C38, C39, C40, C43	CM.1uf
2	3	C10, C13, C34	CT1/16
3	13	C11, C12, C15, C16, C17, C18, C28, C29, C30, C31, C32, C33, C44	CP.22uF
4	8	C20, C21, C22, C23, C24, C25, C26, C27	CP.1uF
5	3	C36, C41, C42	CD1KpF
6	1	C37	CP.33uF
7	1	DL1	L5Y
8	1	DL2	L5V
9	2	DL3, DL5	L5G
10	1	DL4	L5R
11	1	D1	BAT84
12	1	D2	LM336-5.0V
13	1	D5	11DQ06
14	3	JP1, JP3, JP5	JUMP2
15	1	JP2	STRIP 14
16	4	JP4, JP6, JP7, JP10	JUMPER3
17	1	JP8	JUMPER
18	1	JP9	STRIP 2
19	1	J3	FLAT 40P
20	3	Q1, Q3, Q4	BC337
21	6	RP1, RP2, RP8, RP9, R15, R16	10K
22	3	RP3, RP7, RP15	2K2
23	4	RP4, RP5, RP6, R14	47K
24	3	R8, RP10, RP11	47R
25	2	RP12, R13	10R
26	2	RP13, R18	470R
27	1	RP14	3K3
28	1	R1	10M
29	5	S1, S2, S3, S4, S5	SW
30	1	S6	INT
31	1	TR1	87W-10K
32	1	U1	68HC11F1
33	1	U2	MB3773
34	1	U3	27C256
35	1	U4	74HC594
36	1	U5	74HC139
37	1	U6	74HC165
38	1	U7	PCF8584
39	3	U8, U11, U12	40106
40	2	U9, U10	ULN2004A
41	1	U13	LM317
42	1	Y1	CST-8MhZ

PROTPJ-HCLCD



ARCHIVING : 'RVRUT' SERVER, 'RILASCIATI' FOLDER | PROJECT CODE : 014 | DOCUMENT CODE : PROTPJ-HCLCD

PRODUCT NAME : HCS-10 | PART NAME : CPU Display Section Component Layout

DESIGNER : GP - Rev.: J. Berti | DATE : 11/02/04 | REVISION : 2.0 | SCALE : 1:1 | SIZE : A4 | PAGE : 1 DI 1

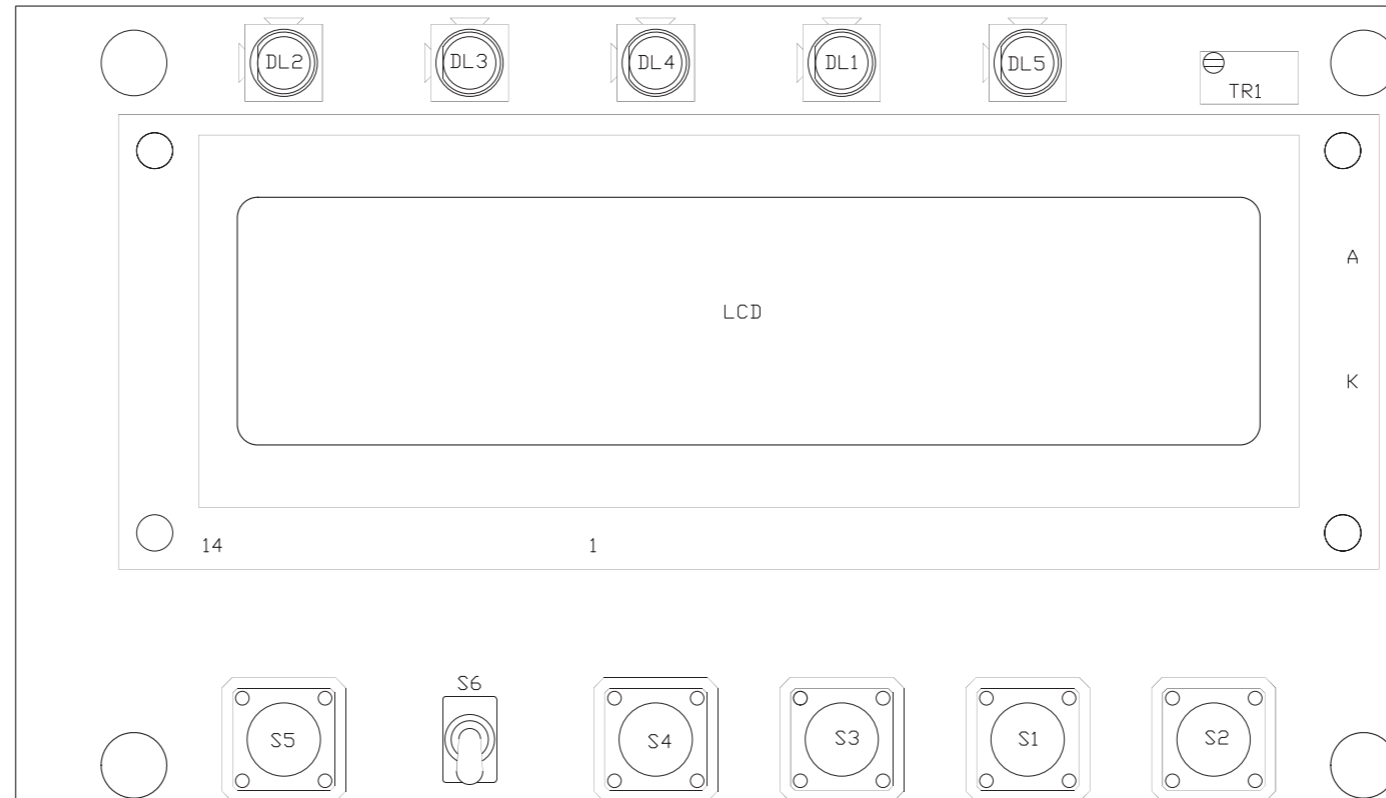

SLADPCNPRTPJ

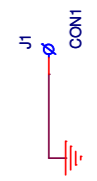
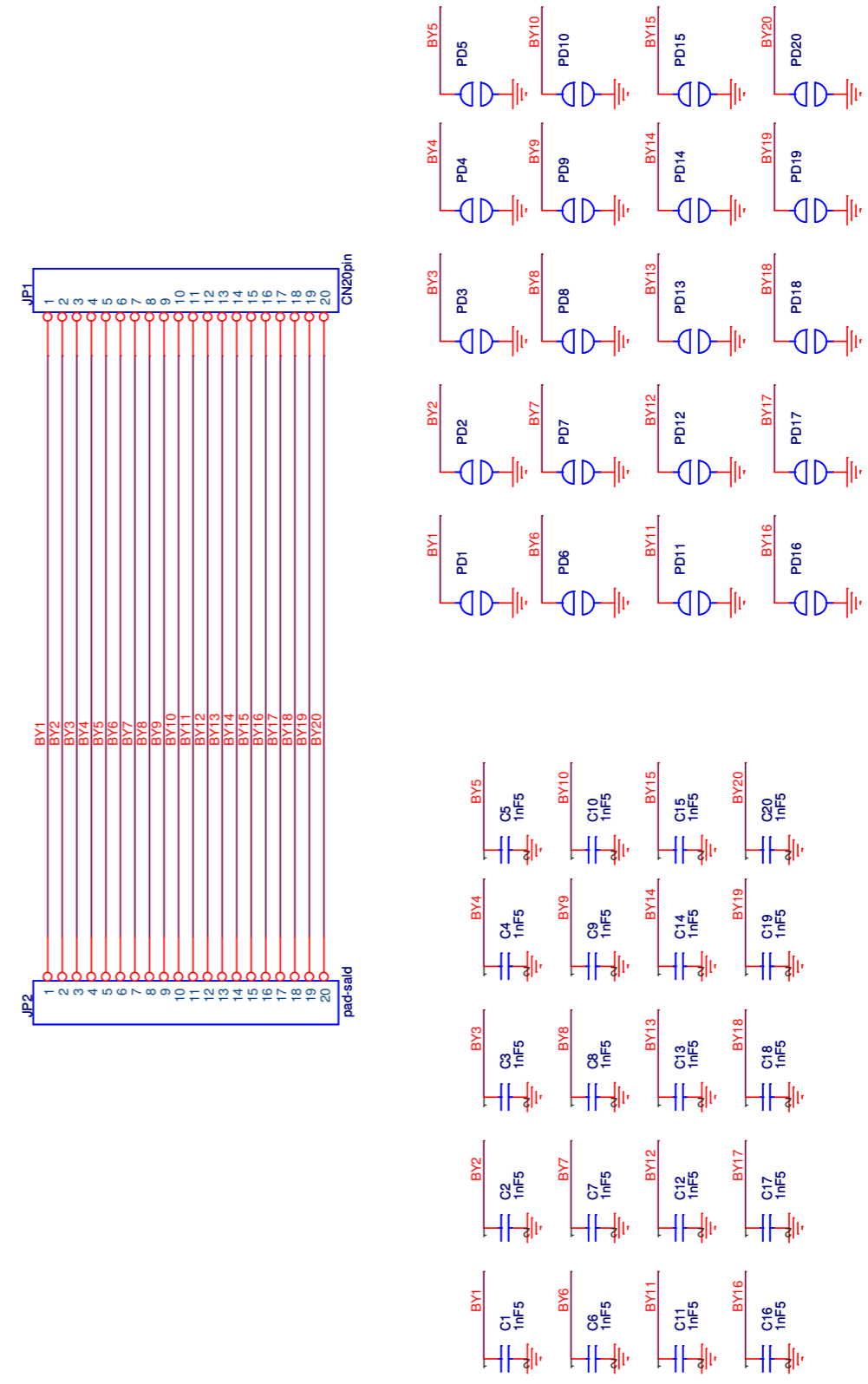
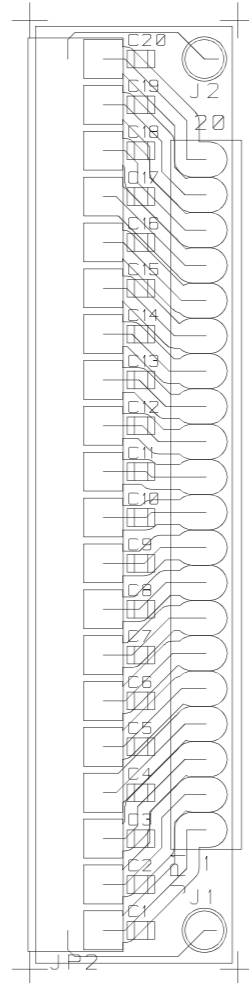

CS1
CSADPCNPRTPJ



Description: CPU Adapter card	
Designer: UT	Page: 1 of 1
Size: A4	Rev. 2.1
Part No.: SLADPCNPRTPJ	Date: 11/03/2005

	PRODUCT NAME : PJ / HC	PART NAME : CPU Adapter card
	DESIGNER : UT	DATE : 11/03/05
ARCHIVING : *RVTRUT* SERVER, *RILASCIATI* FOLDER	PROJECT CODE : <>	DOCUMENT CODE : SLADPCNPRTPJ

SLADPCNPRTPJ

CPU Adapter card Revised: Friday, March 11, 2005
 SLADPCNPRTPJ Revision: 2.1
 UT

Item	Quantity	Reference	Part	Description
1	1	CS1	CSADPCNPRTPJ	Printed circuit board
2	20	C1, C2, C3, C4, C5, C6, C7, C8, C9, C10, C11, C12, C13, C14, C15, C16, C17, C18, C19, C20	1nF5	Ceramic capacitor 0805 X7R
3	1	JP1	CN20pin	stripped female connector 20pin turned
4	1	JP2	pad-sald	Solder pad
5	1	J1	CON1	Solder pad
6	20	PD1, PD2, PD3, PD4, PD5, PD6, PD7, PD8, PD9, PD10, PD11, PD12, PD13, PD14, PD15, PD16, PD17, PD18, PD19, PD20		Solder pad



100W Single Output with PFC Function

EPP-100 series

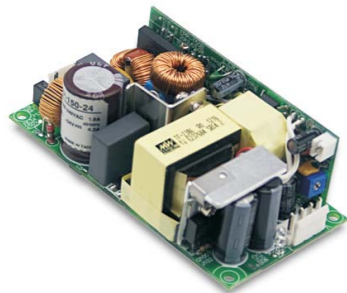

- Features :
 - 4"x2" Compact size
 - Universal AC input / Full range
 - Built-in active PFC function
 - High efficiency up to 92.5%
 - Protections: Short circuit / Overload / Over voltage/Over temperature
 - 75W free air convection, 100W with 20CFM forced air
 - LED indicator for power on
 - No load power consumption<0.5W
 - Built-in 12V/0.3A auxiliary output
 - 3 years warranty



SPECIFICATION

MODEL	EPP-100-12	EPP-100-15	EPP-100-24	EPP-100-27	EPP-100-48	
OUTPUT	DC VOLTAGE	12V	15V	24V	27V	48V
	RATED CURRENT (convection)	6.3A	5A	3.2A	2.8A	1.6A
	RATED CURRENT (20CFM FAN)	8.5A	6.67A	4.2A	3.71A	2.1A
	CURRENT RANGE (convection)	0 ~ 6.3A	0 ~ 5A	0 ~ 3.2A	0 ~ 2.8A	0 ~ 1.6A
	CURRENT RANGE (20CFM FAN)	0 ~ 8.5A	0 ~ 6.67A	0 ~ 4.2A	0 ~ 3.71A	0 ~ 2.1A
	RATED POWER (convection)	75.6W	75W	76.8W	75.6W	76.8W
	RATED POWER (20CFM FAN)	102W	100.05W	100.8W	100.17W	100.8W
	RIPPLE & NOISE (max.) Note.2	120mVp-p	150mVp-p	240mVp-p	240mVp-p	300mVp-p
	VOLTAGE ADJ. RANGE	11.76 ~ 12.6V	14.7 ~ 15.75V	23.52 ~ 25.2V	26.46 ~ 28.35V	47.04 ~ 50.4V
	VOLTAGE TOLERANCE Note.3	±2.0%	±2.0%	±1.0%	±1.0%	±1.0%
LINE REGULATION	±0.5%	±0.5%	±0.5%	±0.5%	±0.5%	
LOAD REGULATION	±1.0%	±1.0%	±1.0%	±1.0%	±1.0%	
SETUP, RISE TIME	1000ms, 30ms/230VAC		2000ms, 30ms/115VAC at full load			
HOLD UP TIME (Typ.)	16ms/230VAC	16ms/115VAC at full load				
INPUT	VOLTAGE RANGE Note.5	90 ~ 264VAC	127 ~ 370VDC			
	FREQUENCY RANGE	47 ~ 63Hz				
	POWER FACTOR (Typ.)	PF>0.95/230VAC		PF>0.98/115VAC at full load		
	EFFICIENCY (Typ.)	91%	91%	92%	92.5%	92.5%
	AC CURRENT (Typ.)	1.4A/115VAC		0.7A/230VAC		
	INRUSH CURRENT (Typ.)	COLD START 70A/230VAC				
	LEAKAGE CURRENT	<2mA/240VAC				
PROTECTION	OVER LOAD	105 ~ 145% rated output power Protection type : Hiccup mode, recovers automatically after fault condition is removed				
	OVER VOLTAGE	13.2 ~ 15.6V	16.83 ~ 19.5V	27.7 ~ 31.5V	30.2 ~ 34.05V	51.3 ~ 62.7V
	OVER TEMPERATURE	110°C ± 10°C (RTH2), 110°C ± 5°C (TSW2) Protection type : Shut down o/p voltage, re-power on to recover				
FUNCTION	AUXILIARY POWER(AUX)	12V@0.3A for driving a fan, tolerance ± 10% at main output 100% load				
	WORKING TEMP.	-30 ~ +70°C (Refer to "Derating Curve")				
ENVIRONMENT	WORKING HUMIDITY	20 ~ 90% RH non-condensing				
	STORAGE TEMP., HUMIDITY	-40 ~ +85°C, 10 ~ 95% RH				
	TEMP. COEFFICIENT	±0.03%/°C (0 ~ 45°C)				
	VIBRATION	10 ~ 500Hz, 2G 10min./1cycle, period for 60min. each along X, Y, Z axes				
SAFETY & EMC (Note 4)	SAFETY STANDARDS	UL60950-1, TUV EN60950-1 approved				
	WITHSTAND VOLTAGE	I/P-O/P:3KVAC I/P-FG:2KVAC O/P-FG:0.5KVAC				
	ISOLATION RESISTANCE	I/P-O/P, I/P-FG, O/P-FG:100M Ohms / 500VDC / 500VDC / 25°C / 70% RH				
	EMC EMISSION	Compliance to EN55022 (CISPR22) Class B, EN61000-3-2,-3				
OTHERS	EMC IMMUNITY	Compliance to EN61000-4-2,3,4,5,6,8,11, heavy industry level, criteria A				
	MTBF	249.6Khrs min. MIL-HDBK-217F (25°C)				
NOTE	DIMENSION	101.6*50.8*29mm (L*W*H)				
	PACKING	0.2Kg; 72pcs/15.4Kg/0.82CUFT				

File Name:EPP-100-SPEC 2012-09-10



100W Single Output with PFC Function

EPP-100 series

■ Mechanical Specification

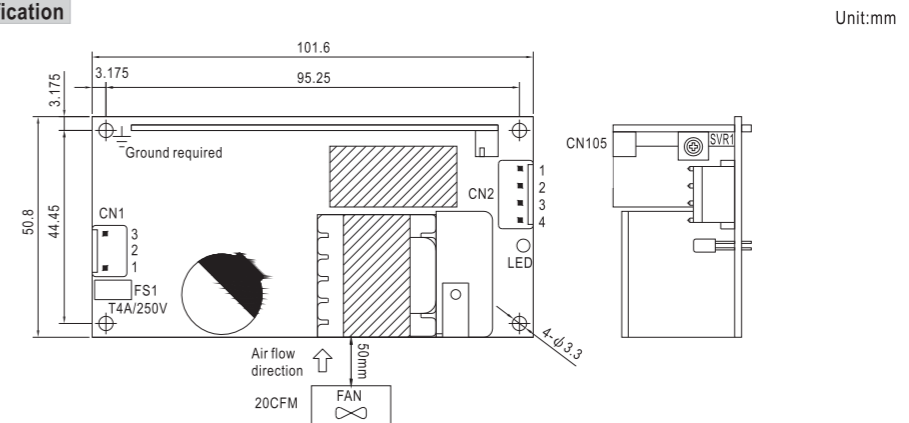

AC Input Connector (CN1) : JST B3P-VH or equivalent

Pin No.	Assignment	Mating Housing	Terminal
1	AC/L	JST VHR or equivalent	JST SVH-21T-P1.1 or equivalent
2	No Pin		
3	AC/N		

DC Output Connector (CN2) : JST B4P-VH or equivalent

Pin No.	Assignment	Mating Housing	Terminal
1,2	DC COM	JST VHR or equivalent	JST SVH-21T-P1.1 or equivalent
3,4	+V		

FAN Connector(CN105) : JST B2B-PH-K-S or equivalent

Pin No.	Assignment	Mating Housing	Terminal
1	+12V	JST PHR-2 or equivalent	JST SPH-002T-P0.5S or equivalent
2	DC COM		

⊕ : Grounding required

■ Block Diagram

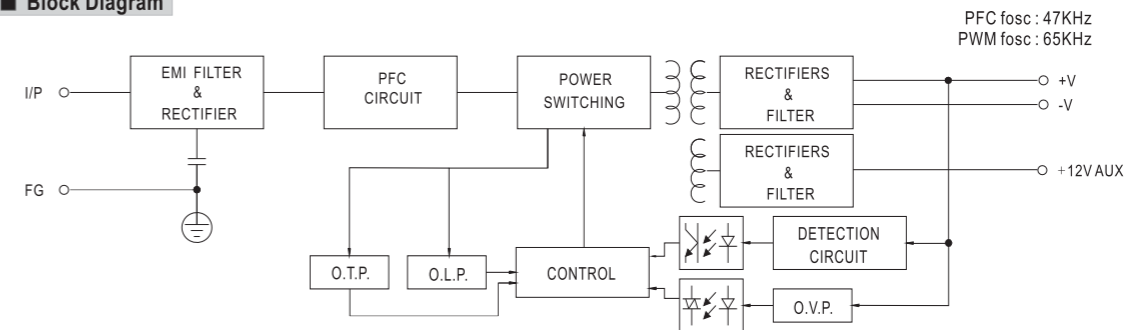

■ Output Derating

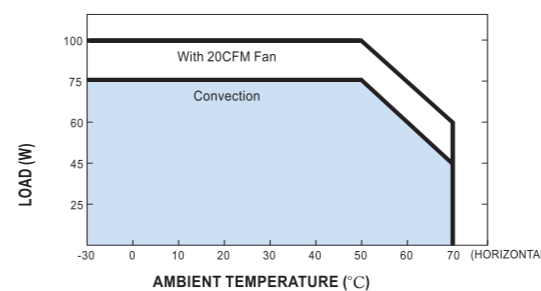

■ Output Derating VS Input Voltage

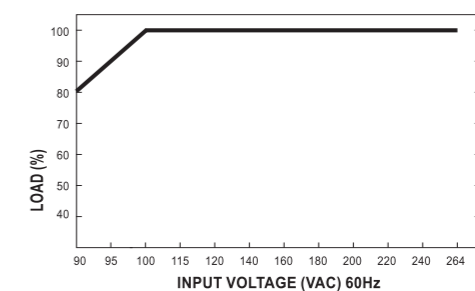

File Name:EPP-100-SPEC 2012-09-10

SLIN0411R02V01

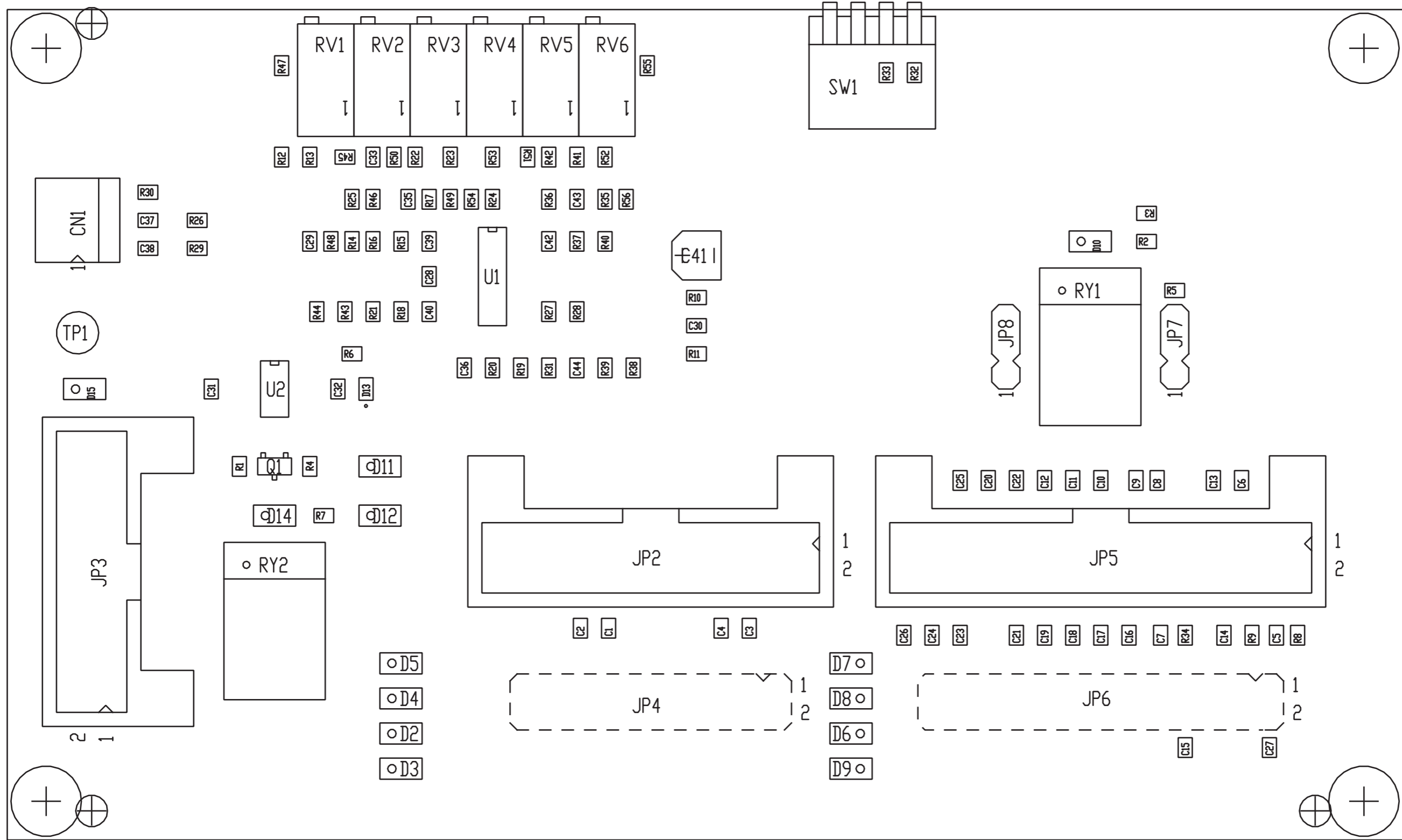

PRODUCT NAME : HC2-5GRL	PART NAME : INTERFACE PROT-F ADD-ON
DESIGNER : A. Tommasi	DATE : 23/03/15
ARCHIVING : 'RVRUT' SERVER, 'RILASCIATI' FOLDER	REVISION : 1.0
	SCALE : 2:1
	SIZE : A4
	PAGE : 1
	DI : 1
	DOCUMENT CODE : SLIN0411R02V01
	PROJECT CODE : 021

SLIN0411R02V01

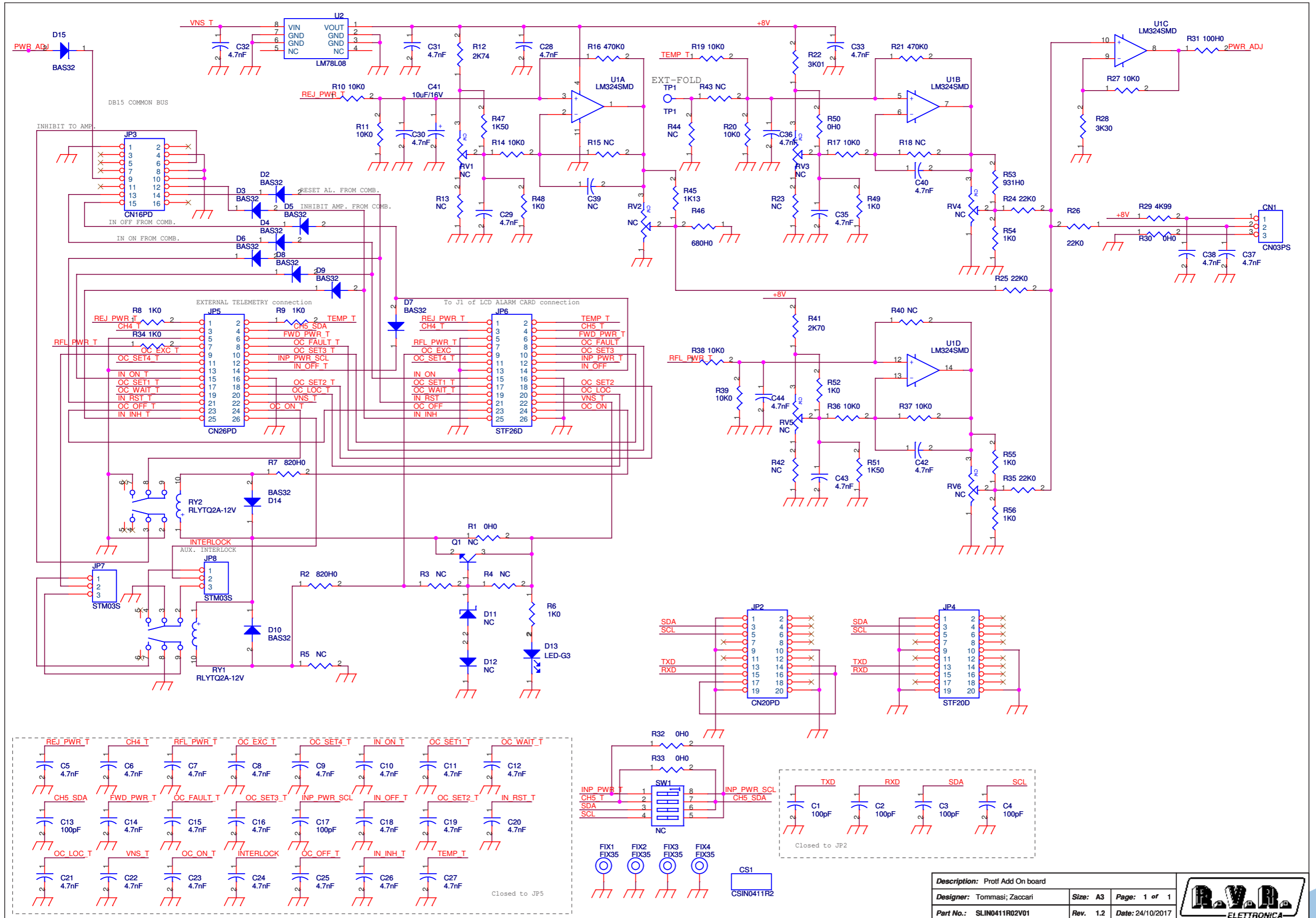

Description: Protif Add On board			
Designer: Tommasi, Zaccari	Size: A3	Page: 1 of 1	
Part No.: SLIN0411R02V01	Rev.: 1.2	Date: 24/10/2017	



SLIN0411R02V01

Protf Add On board Revised: 24/10/2017
 SLIN0411R02V01 Revision: 1.2
 Tommasi; Zaccari

Item	Quantity	Reference	Part	Description
1	1	CN1	CN03PS	3 poles Mascon connector
2	1	CS1	CSIN0411R2	Printed circuit board
3	6	C1, C2, C3, C4, C13, C17	100pF	SMD capacitor 0805
4	35	C5, C6, C7, C8, C9, C10, C11, C12, C14, C15, C16, C18, C19, C20, C21, C22, C23, C24, C25, C26, C27, C28, C29, C30, C31, C32, C33, C35, C36, C37, C38, C40, C42, C43, C44	4.7nF	SMD capacitor 0805
5	1	C39	NC	SMD capacitor 0805
6	1	C41	10uF/16V	SMD electrolytic capacitor d. 4mm
7	11	D2, D3, D4, D5, D6, D7, D8, D9, D10, D14, D15	BAS32	MINIMELF SMD Diode
8	1	D11	NC	MINIMELF SMD Zener Diode
9	1	D12	NC	MINIMELF SMD Diode
10	1	D13	LED-G3	LED SMD 0805
11	4	FIX1, FIX2, FIX3, FIX4	FIX35	fixing hole 3.5mm
12	1	JP2	CN20PD	20 poles connectors Flat pc
13	1	JP3	CN16PD	16 poles connectors Flat pc
14	1	JP4	STF20D	Female strip 10+10 pin
15	1	JP5	CN26PD	26 poles connector Flat pc
16	1	JP6	STF26D	Female strip 13+13 pin
17	2	JP7, JP8	STM03S	Male strip 3 pin
18	1	Q1	NC	Trans. NPN SOT23
19	6	RV1, RV2, RV3, RV4, RV5, RV6	NC	Trimmer Rg H 3296X
20	2	RY1, RY2	RLYTQ2A-12V	Relay TQ2
21	5	R1, R30, R32, R33, R50	0H0	SMD resistor 0805
22	2	R2, R7	820H0	SMD resistor 0805
23	11	R3, R4, R5, R13, R15, R18, R23, R40, R42, R43, R44	NC	SMD resistor 0805
24	10	R6, R8, R9, R34, R48, R49, R52, R54, R55, R56	1K0	SMD resistor 0805
25	11	R10, R11, R14, R17, R19, R20, R27, R36, R37, R38, R39	10K0	SMD resistor 0805
26	1	R12	2K74	SMD resistor 0805
27	2	R16, R21	470K0	SMD resistor 0805
28	1	R22	3K01	SMD resistor 0805
29	4	R24, R25, R26, R35	22K0	SMD resistor 0805
30	1	R28	3K30	SMD resistor 0805
31	1	R29	4K99	SMD resistor 0805
32	1	R31	100H0	SMD resistor 0805
33	1	R41	2K70	SMD resistor 0805
34	1	R45	1K13	SMD resistor 0805
35	1	R46	680H0	SMD resistor 0805
36	2	R47, R51	1K50	SMD resistor 0805
37	1	R53	931H0	SMD resistor 0805
38	1	SW1	NC	Dip switch 4 way
39	1	TP1	TP1	Test point
40	1	U1	LM324SMD	Quad Op. SMD SO14
41	1	U2	LM78L08	SMD stabilizer SO8

SL042MT1001

W1 LINK CONFIGURATION

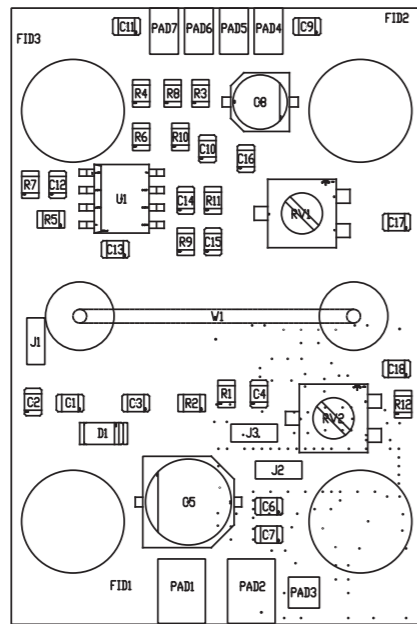
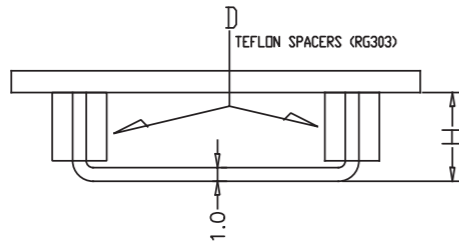

- J1: 88-108 MHz LINEARITY
- J2: LIGHT STABILIZER DELAY SYSTEM
- J3: HEAVY STABILIZER DELAY SYSTEM
- PAD1: GND (PASSIVE RF MEASUREMENT)
- PAD2: SIGNAL (PASSIVE RF MEASUREMENT)
- PAD3: SIGNAL GND (PASSIVE RF MEASUREMENT)
- PAD4: +12VCC (AMPLIF. RF MEASUREMENT)
- PAD5: SIGNAL GND (AMPLIF. RF MEASUREMENT)
- PAD6: GND (AMPLIF. RF MEASUREMENT)
- PAD7: SIGNAL (AMPLIF. RF MEASUREMENT)
- RV1: DIRECTIVITY ADJUSTMENT
- RV2: NORMALIZATION LEVEL

CONFIGURATIONS DETAIL

CARD CODE	H link W1 (mm)	W1 code AS400	D spacers W1	Jumper J1	Jumper J2	Jumper J3
SL042MT1001		none				
SL042MT1101	5.3	B0B10020001A		X		
SL042MT1201	4	B0B10020002A		X		
SL042MT1301	7.6	B0B10020003A		X		
SL042MT1401	8.5	B0B10020004A	X	X		X
SL042MT1501	4.5	B0B10020005A		X		
SL042MT1601	5.5	B0B10020006A	X	X		X

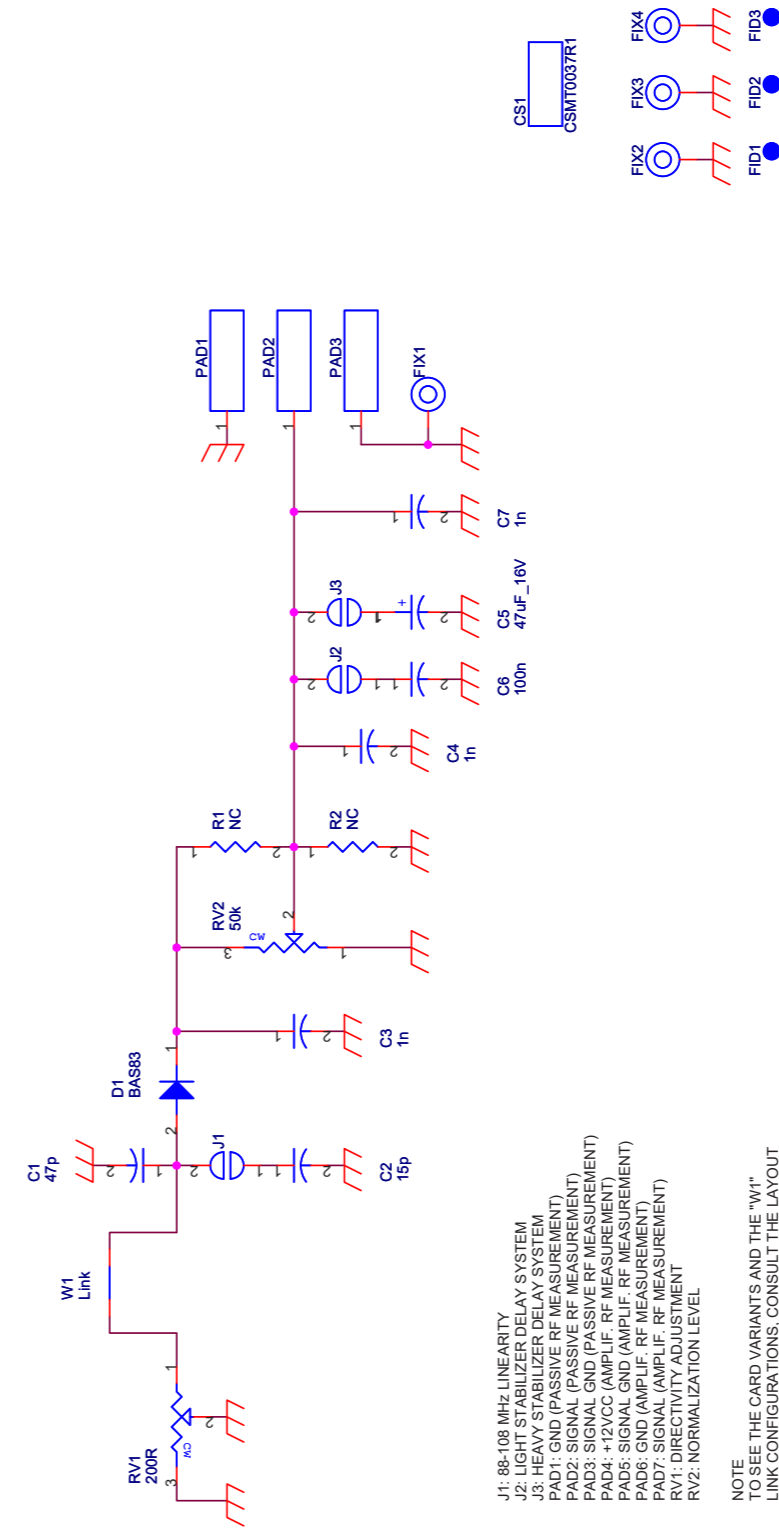

J1: 88-108 MHz LINEARITY
 J2: LIGHT STABILIZER DELAY SYSTEM
 J3: HEAVY STABILIZER DELAY SYSTEM
 PAD1: GND (PASSIVE RF MEASUREMENT)
 PAD2: SIGNAL (PASSIVE RF MEASUREMENT)
 PAD3: SIGNAL GND (PASSIVE RF MEASUREMENT)
 PAD4: +12VCC (AMPLIF. RF MEASUREMENT)
 PAD5: SIGNAL GND (AMPLIF. RF MEASUREMENT)
 PAD6: GND (AMPLIF. RF MEASUREMENT)
 PAD7: SIGNAL (AMPLIF. RF MEASUREMENT)
 RV1: DIRECTIVITY ADJUSTMENT
 RV2: NORMALIZATION LEVEL

NOTE
 TO SEE THE CARD VARIANTS AND THE "W1"
 LINK CONFIGURATIONS, CONSULT THE LAYOUT
 (SL042MT1001-DWG)



Description: Generic RF PWR Measurement
 Designer: Mauro Ucelli
 Part No.: SL042MT1001
 Page: 1 of 1
 Size: A4
 Rev: 1.1
 Date: 17/04/2006



PRODUCT NAME : HC2/2
 PART NAME : POWER METER
 DESIGNER : M. UCELLI
 DATE : 27/09/11
 REVISION : 1.0
 SCALE : 2:1
 SIZE : A4
 PAGE : 1 DI 1

ARCHIVING : 'RVRUT' SERVER, 'RILASCIATI' FOLDER
 PROJECT CODE : 042
 DOCUMENT CODE : SL042MT1001

SL042MT1001

RF Power measure board
 SL042MT1001
 Revision: 1.1
 Generic RF PWR Measurement
 042
 Mauro Ucelli
 17/04/2008

Item	Quantity	Reference	Part	Description
1	1	CS1	CSMT0037R1	Printed Circuit Board
2	1	C1	47p	SMD 0805 COG Capacitor
3	1	C2	15p	SMD 0805 COG Capacitor
4	3	C3,C4,C7	1n	SMD 0805 Capacitor
5	1	C5	47uF 16V	Elect. SMD d. 6.3mm Cap.
6	1	C6	100n	SMD 0805 Capacitor
7	1	D1	BAS83	MINIMELF SMD Diode
8	3	FID1,FID2,FID3	FID	
9	4	FIX1,FIX2,FIX3,FIX4	FIX35	Fixing Hole 3.5mm
10	3	J1,J2,J3	JSMD	SMD Pad to solder
11	3	PAD1,PAD2,PAD3	PAD	
12	1	RV1	200R	Trimmer SMD
13	1	RV2	50k	Trimmer SMD
14	2	R1,R2	NC	SMD 0805 Res.
15	1	W1	Link	Wire to solder