

HC HE

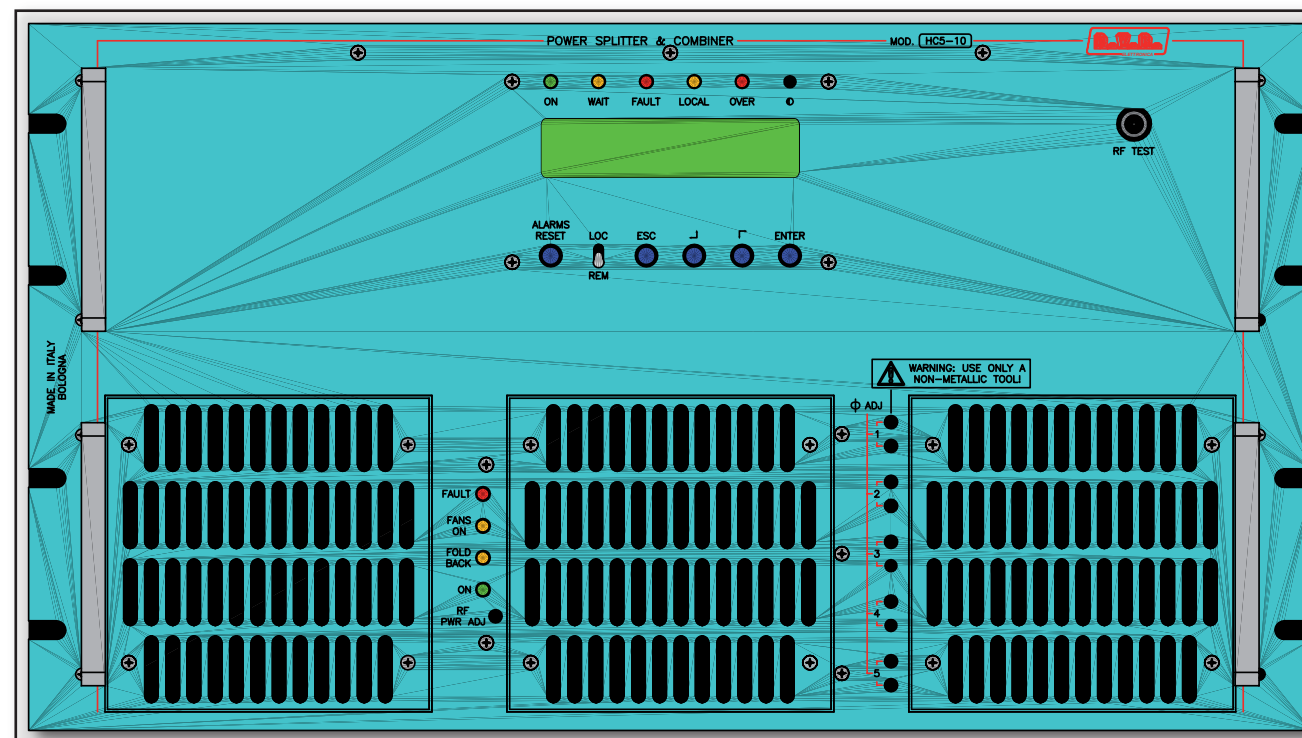

User Manual Volume 2: Technical Appendix

Appendix A Piani di montaggio, schemi elettrici, liste componenti / *Component layouts, schematics, bills of material*

Questa parte del manuale contiene i dettagli tecnici riguardanti la costruzione delle singole schede componenti il HC HE. L'appendice è composta dalle seguenti sezioni:

This part of the manual contains the technical details about the different boards of the HC HE. This appendix is composed of the following sections:

<i>Description</i>	HC2HE <i>RVR Code</i>	HC3HE <i>RVR Code</i>	HC4HE <i>RVR Code</i>	<i>Vers.</i>	<i>Page</i>
Wiring Diagram 2Way	Yes	/	/	1.0	1
Wiring Diagram 3Way	/	Yes	/	1.0	7
Wiring Diagram 4Way	/	/	Yes	1.0	13
Phase Shifter 2 Way	SLPHSHHC2-02	/	/	1.0	19
Phase Shifter 3 Way	/	SLPHSHHC3-02	/	1.0	21
Phase Shifter 4 Way	/	/	SLPHSHHC4-02	1.0	23
Power Splitter 2 Way	SLSPLTHC2-01	/	/	1.0	25
Power Splitter 3 Way	/	SLSPLTHC3-01	/	1.0	28
Power Splitter 4 Way	/	/	SLSPLTHC4-01	1.0	31
Power Combiner	SLCMB25VHC52	SLCMB25VHC52	SLCMB25VHC52	1.0	34
CPU Section	PROTPJ-HCL	PROTPJ-HCL	PROTPJ-HCL	3.0	35
Walk-through filter	SLFILPJ1KM	SLFILPJ1KM	SLFILPJ1KM	2.0	41
Dir. Coupler	SL042MT1301	SL042MT1301	SL042MT1301	1.1	43
Absorber & Measure circuit	SLPWRSENHHC52	SLPWRSENHHC52	SLPWRSENHHC52	1.0	45
General Main Interface Circuit	SLINHC5-10-2	SLINHC5-10-2	SLINHC5-10-2	1.1	47
CPU card	CPUPJ2KMC	CPUPJ2KMC	CPUPJ2KMC	1.0	53
LEds card	SLLEDREPJ2K1	SLLEDREPJ2K1	SLLEDREPJ2K1	1.0	58
Absorbers μ C Circuit	SLADKDIPJ5K2	SLADKDIPJ5K2	SLADKDIPJ5K2	1.0	60

Document History

Date	Version	Reason	Code	Editor
30/06/11	1.0	First Release in A3 Format	N.D.	J.H. Berti

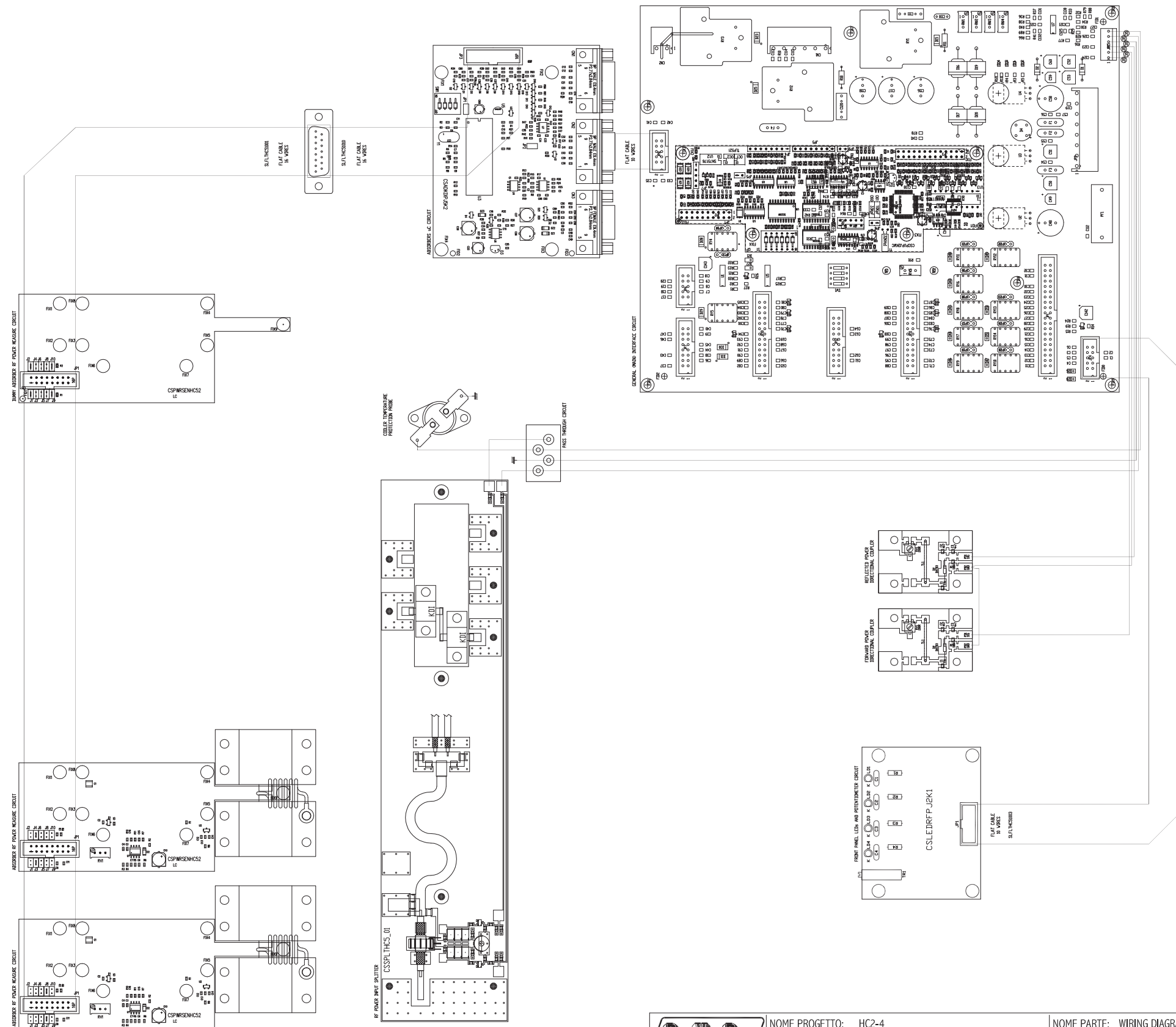

	NOME PROGETTO: HC2-4	NOME PARTE: WIRING DIAGRAM			
	AUTORE: M. UCCELLI	DATA: 19/04/2004	REVISIONE: 1.0	SCALA: 1:2	SIZE: A3
ARCHIVIAZIONE ELETTRONICA: "CARTELLA PROGETTI" SU "UT_SRV"		CODICE PROGETTO: 017	CODICE DISEGNO: WIRHC24-1		
MATERIALE: <>	TRATTAMENTO: <>	PROFILO: <>	STATO: ESECUTIVO		

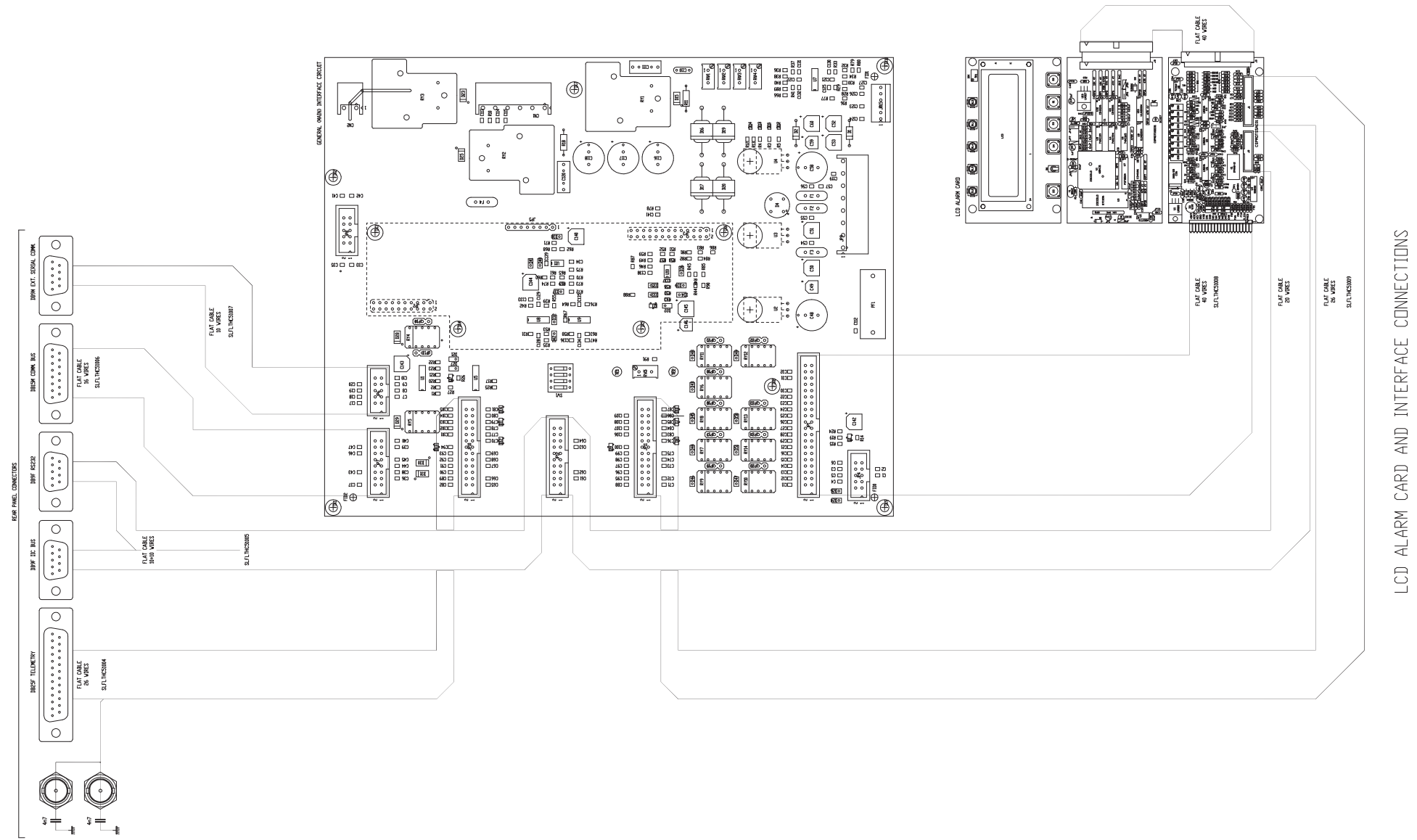

LCD ALARM CARD AND INTERFACE CONNECTIONS

	NOME PROGETTO: HC5/10	NOME PARTE: WIRING DIAGRAM			
	AUTORE: M. UCELLI	DATA: 11/02/2004	REVISIONE: 1.0	SCALA: 1:2	SIZE: A3
ARCHIVIAZIONE ELETTRONICA: "CARTELLA PROGETTI" SU "UT_SRV"		CODICE PROGETTO: 014	CODICE DISEGNO: WIRHC510-1		
MATERIALE: <>	TRATTAMENTO: <>	PROFILO: <>	STATO: ESECUTIVO		

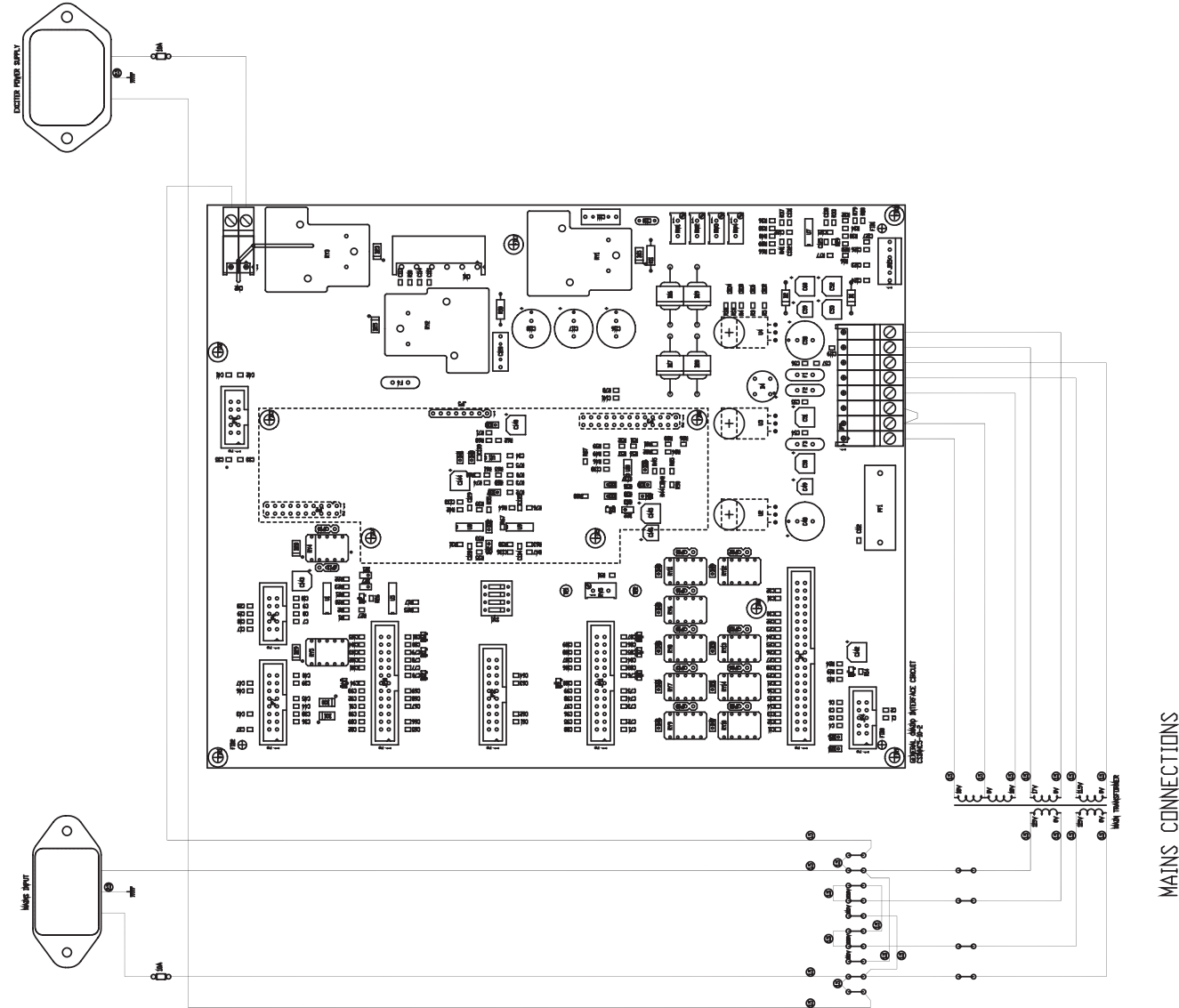

	NOME PROGETTO: HC5/10	NOME PARTE: WIRING DIAGRAM				
	AUTORE: M. UCCELLI	DATA: 11/02/2004	REVISIONE: 1.0	SCALA: 1:2	SIZE: A3	PAGINA: 3 DI 6
ARCHIVIAZIONE ELETTRONICA: "CARTELLA PROGETTI" SU "UT_SRV"		CODICE PROGETTO: 014	CODICE DISEGNO: WIRHC510-1			
MATERIALE: <>	TRATTAMENTO: <>	PROFILO: <>	STATO: ESECUTIVO			

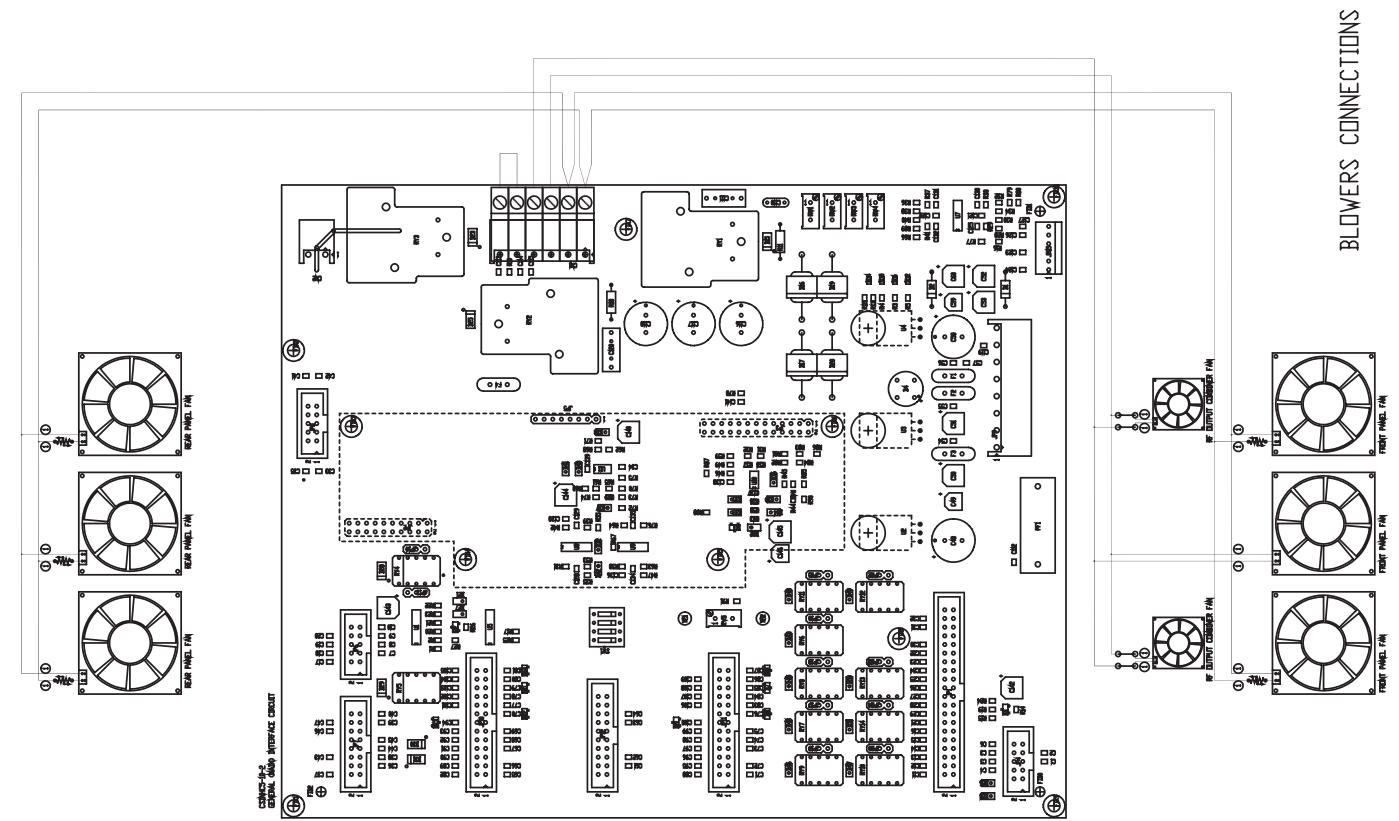

	NOME PROGETTO: HC5/10	NOME PARTE: WIRING DIAGRAM			
	AUTORE: M. UCELLI	DATA: 11/02/2004	REVISIONE: 1.0	SCALA: 1:2	SIZE: A3
ARCHIVIAZIONE ELETTRONICA: "CARTELLA PROGETTI" SU "UT_SRV"		CODICE PROGETTO: 014	CODICE DISEGNO: WIRHC510-1		
MATERIALE: <>	TRATTAMENTO: <>	PROFILO: <>	STATO: ESECUTIVO		

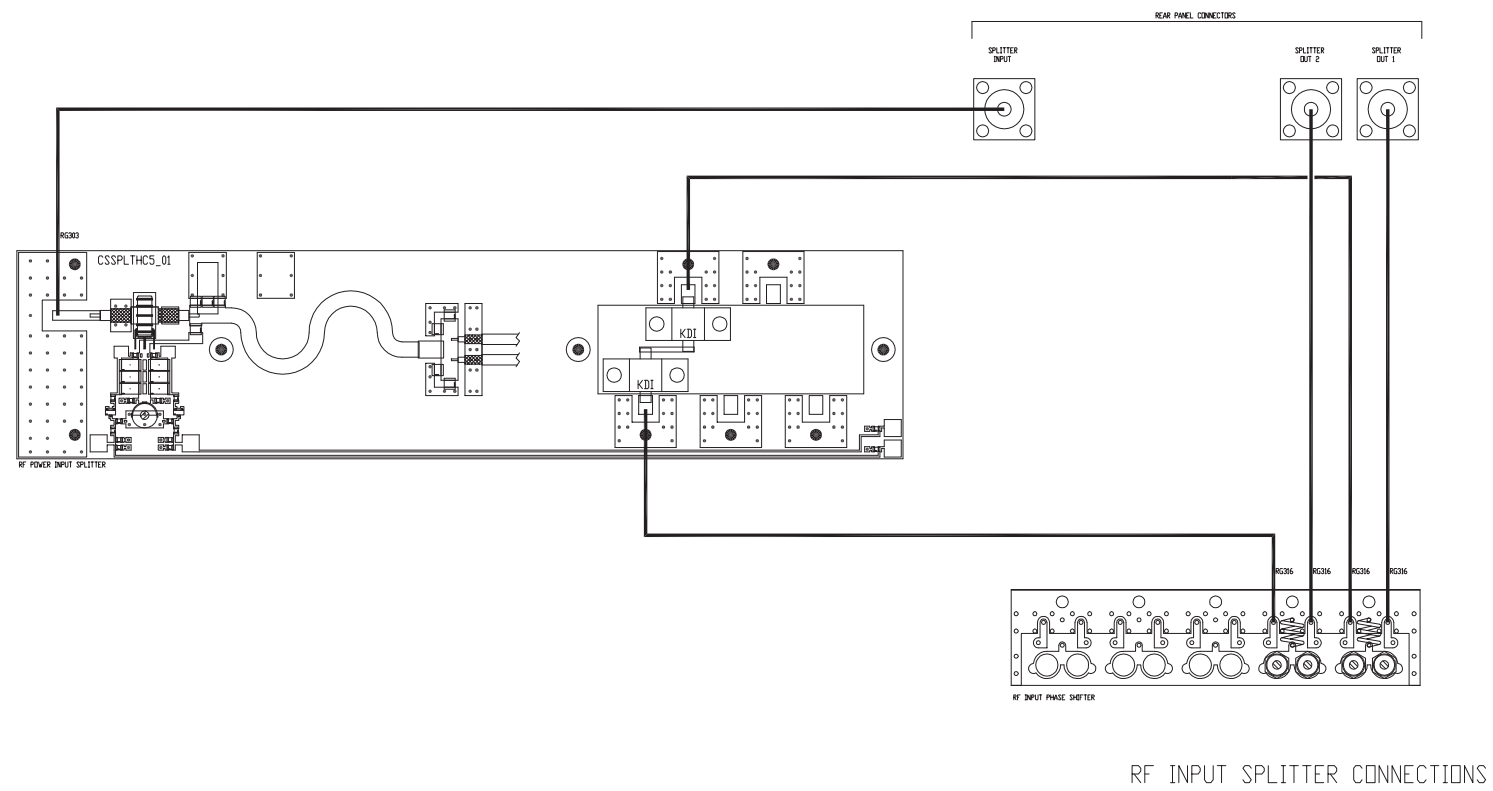

	NOME PROGETTO: HC2-4	NOME PARTE: WIRING DIAGRAM			
	AUTORE: M. UCELLI	DATA: 19/04/2004	REVISIONE: 1.0	SCALA: 1:2	SIZE: A3
ARCHIVIAZIONE ELETTRONICA: "CARTELLA PROGETTI" SU "UT_SRV"		CODICE PROGETTO: 017	CODICE DISEGNO: WIRHC24-1		
MATERIALE: <>	TRATTAMENTO: <>	PROFILO: <>	STATO: ESECUTIVO		

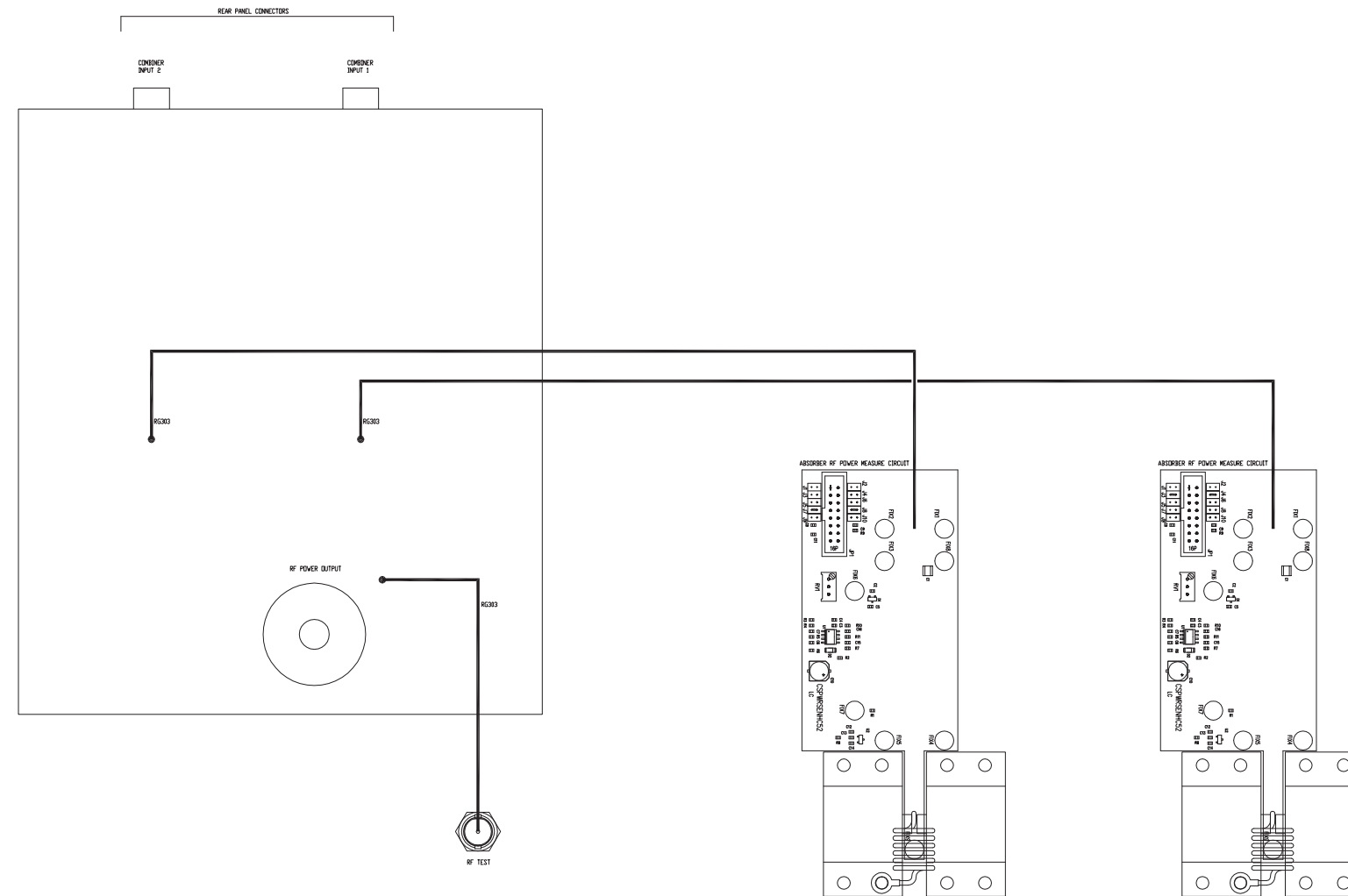

RF OUTPUT COMBINER CONNECTIONS

	NOME PROGETTO: HC2-4	NOME PARTE: WIRING DIAGRAM			
	AUTORE: M. UCCELLI	DATA: 19/04/2004	REVISIONE: 1.0	SCALA: 1:2	SIZE: A3
ARCHIVIAZIONE ELETTRONICA: "CARTELLA PROGETTI" SU "UT_SRV"		CODICE PROGETTO: 017	CODICE DISEGNO: WIRHC24-1		
MATERIALE: <>	TRATTAMENTO: <>	PROFILO: <>	STATO: ESECUTIVO		

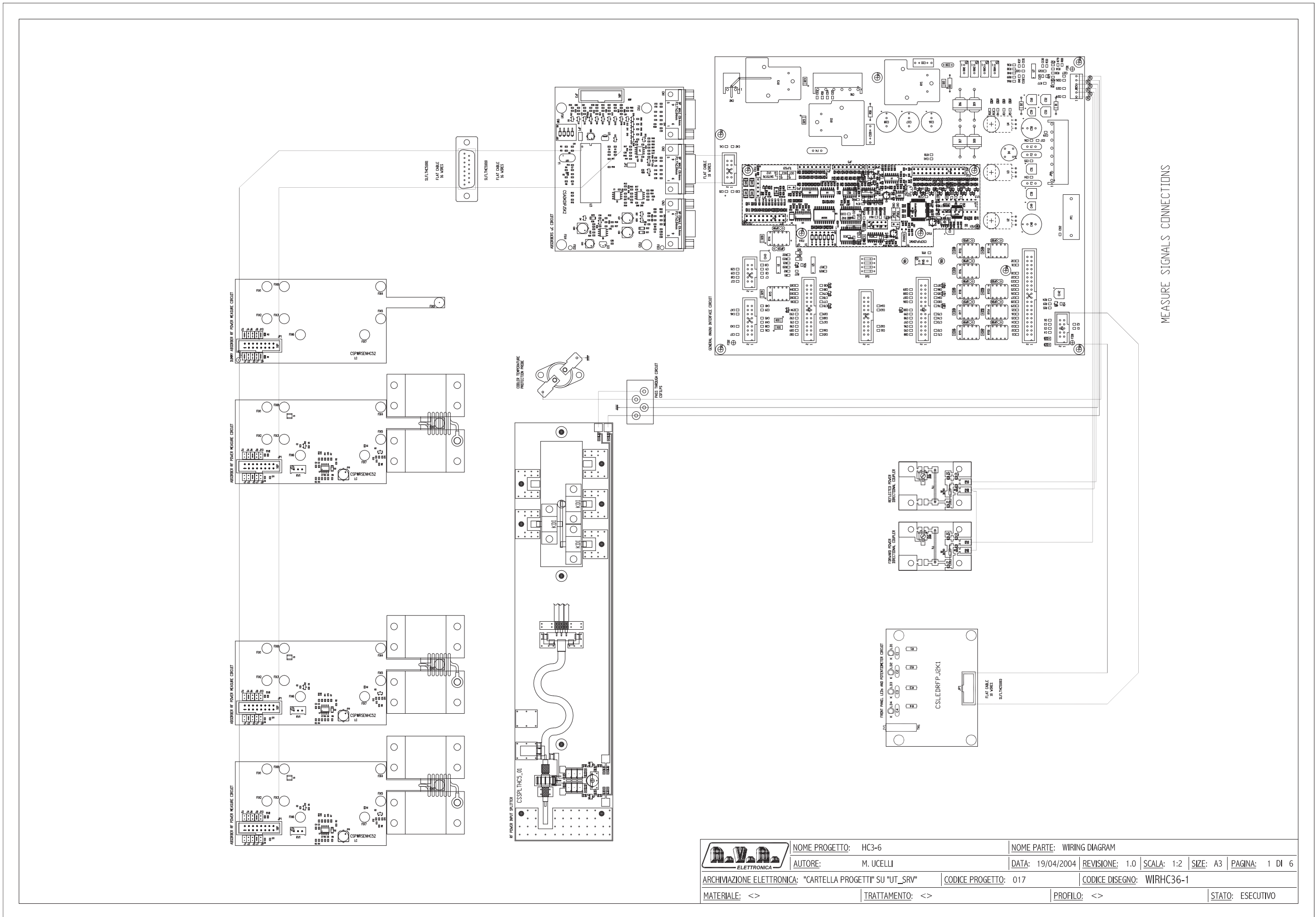

	NOME PROGETTO: HC3-6	NOME PARTE: WIRING DIAGRAM			
	AUTORE: M. UCCELLI	DATA: 19/04/2004	REVISIONE: 1.0	SCALA: 1:2	SIZE: A3
ARCHIVIAZIONE ELETTRONICA: "CARTELLA PROGETTI" SU "UT_SRV"		CODICE PROGETTO: 017	CODICE DISEGNO: WIRHC36-1		
MATERIALE: <>	TRATTAMENTO: <>	PROFILO: <>	STATO: ESECUTIVO		

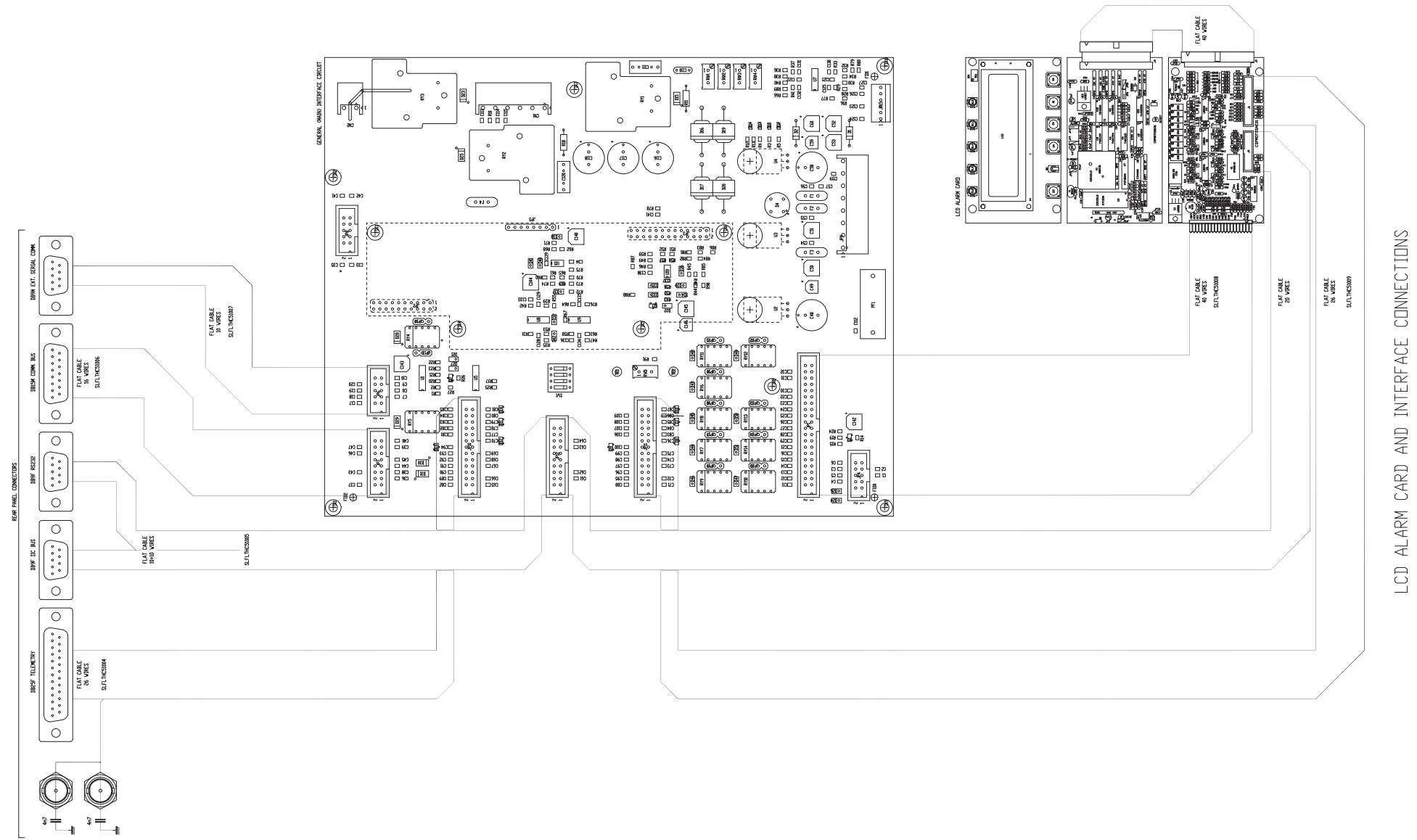

LCD ALARM CARD AND INTERFACE CONNECTIONS

	NOME PROGETTO: HC5/10	NOME PARTE: WIRING DIAGRAM			
	AUTORE: M. UCCELLI	DATA: 11/02/2004	REVISIONE: 1.0	SCALA: 1:2	SIZE: A3
ARCHIVIAZIONE ELETTRONICA: "CARTELLA PROGETTI" SU "UT_SRV"		CODICE PROGETTO: 014	CODICE DISEGNO: WIRHC510-1		
MATERIALE: <>	TRATTAMENTO: <>	PROFILO: <>	STATO: ESECUTIVO		

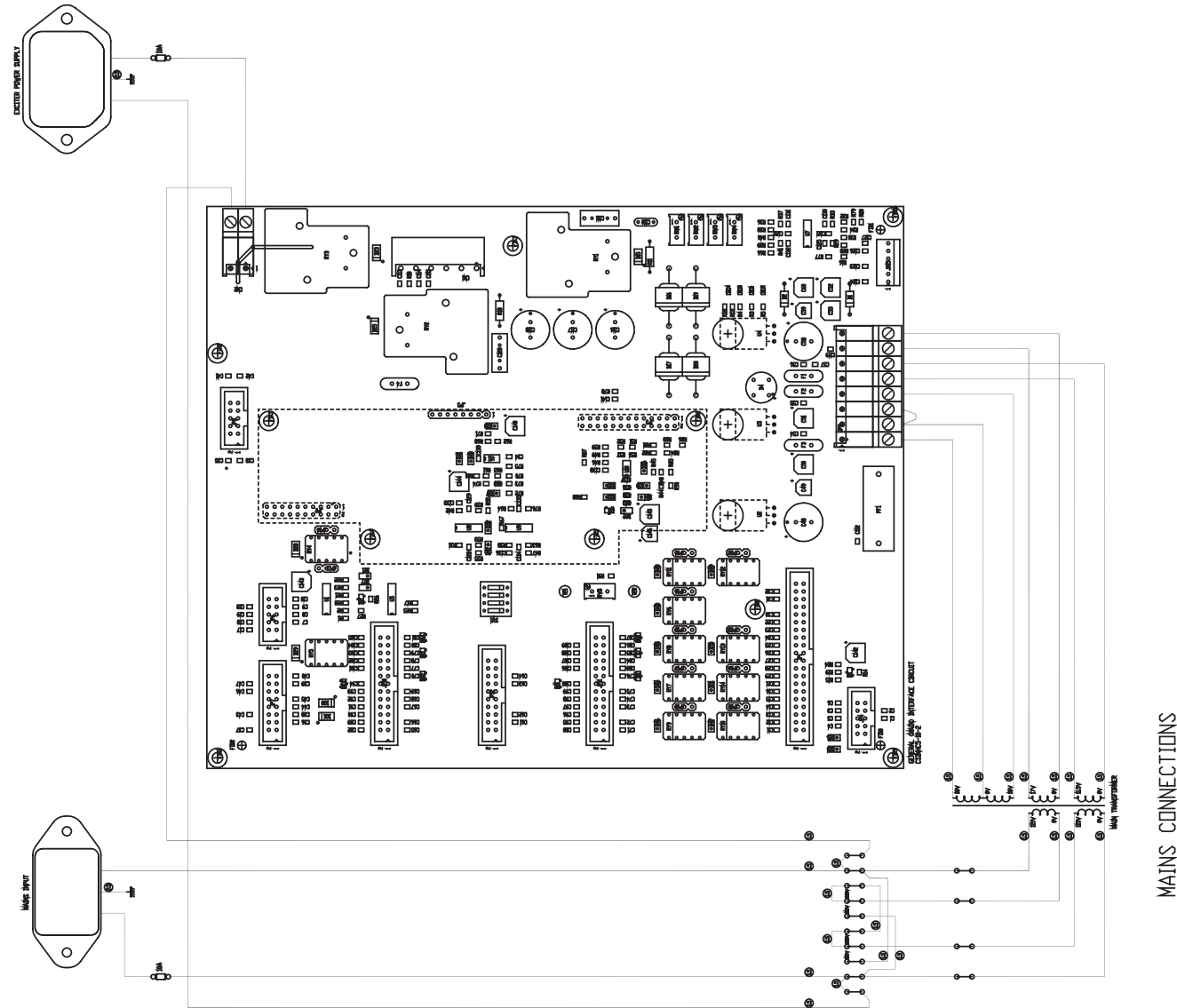

	NOME PROGETTO: HC5/10	NOME PARTE: WIRING DIAGRAM			
	AUTORE: M. UCELLI	DATA: 11/02/2004	REVISIONE: 1.0	SCALA: 1:2	SIZE: A3
ARCHIVIAZIONE ELETTRONICA: "CARTELLA PROGETTI" SU "UT_SRV"		CODICE PROGETTO: 014	CODICE DISEGNO: WIRHC510-1		
MATERIALE: <>	TRATTAMENTO: <>	PROFILO: <>	STATO: ESECUTIVO		

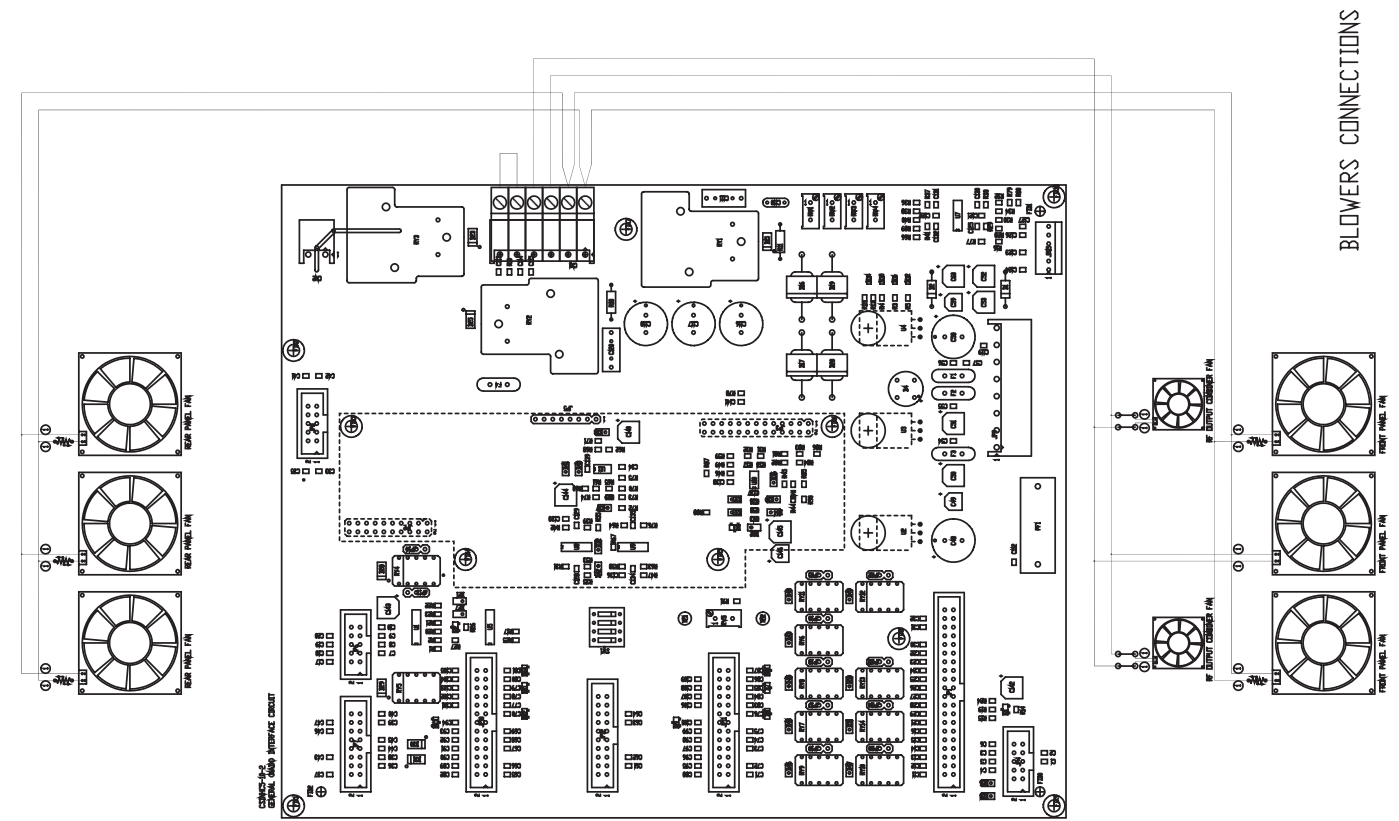

	NOME PROGETTO: HC5/10	NOME PARTE: WIRING DIAGRAM			
	AUTORE: M. UCELLI	DATA: 11/02/2004	REVISIONE: 1.0	SCALA: 1:2	SIZE: A3
ARCHIVIAZIONE ELETTRONICA: "CARTELLA PROGETTI" SU "UT_SRV"		CODICE PROGETTO: 014	CODICE DISEGNO: WIRHC510-1		
MATERIALE: <>	TRATTAMENTO: <>	PROFILO: <>	STATO: ESECUTIVO		

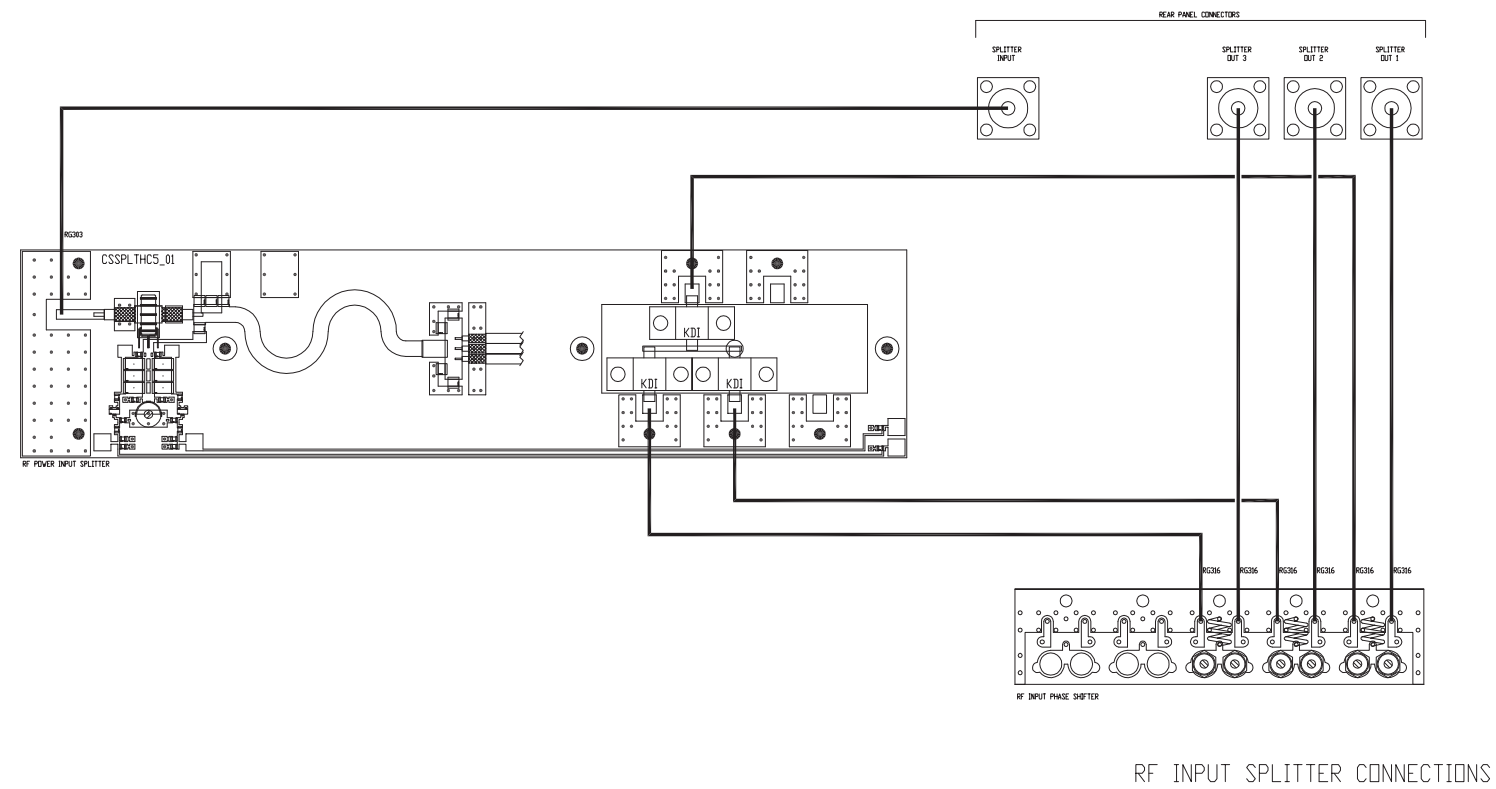

	NOME PROGETTO: HC3-6	NOME PARTE: WIRING DIAGRAM			
	AUTORE: M. UCELLI	DATA: 19/04/2004	REVISIONE: 1.0	SCALA: 1:2	SIZE: A3
ARCHIVIAZIONE ELETTRONICA: "CARTELLA PROGETTI" SU "UT_SRV"		CODICE PROGETTO: 017	CODICE DISEGNO: WIRHC36-1		
MATERIALE: <>	TRATTAMENTO: <>	PROFILO: <>	STATO: ESECUTIVO		

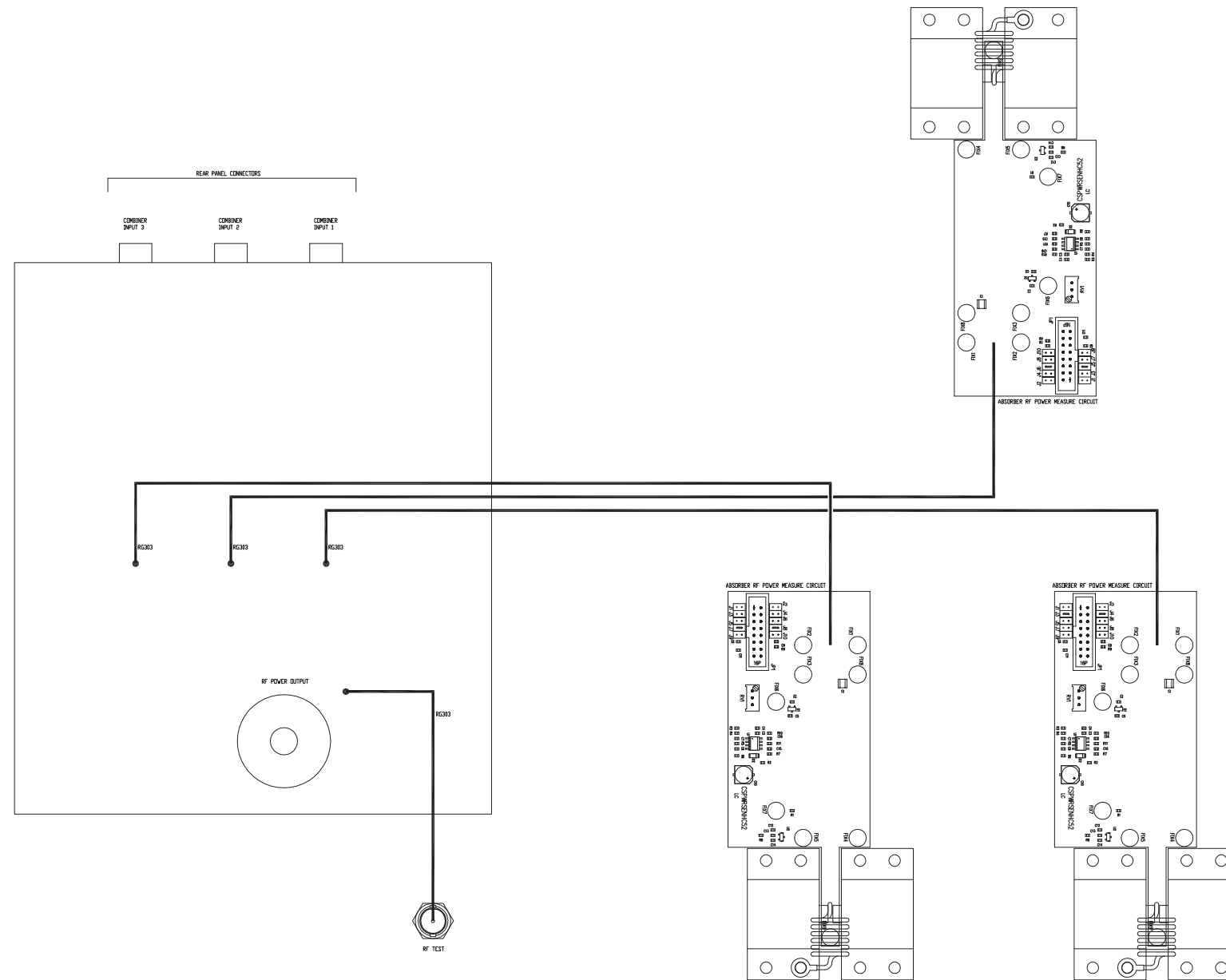

RF OUTPUT COMBINER CONNECTIONS

	NOME PROGETTO: HC3-6	NOME PARTE: WIRING DIAGRAM			
	AUTORE: M. UCCELLI	DATA: 19/04/2004	REVISIONE: 1.0	SCALA: 1:2	SIZE: A3
ARCHIVIAZIONE ELETTRONICA: "CARTELLA PROGETTI" SU "UT_SRV"		CODICE PROGETTO: 017	CODICE DISEGNO: WIRHC36-1		
MATERIALE: <>	TRATTAMENTO: <>	PROFILO: <>	STATO: ESECUTIVO		

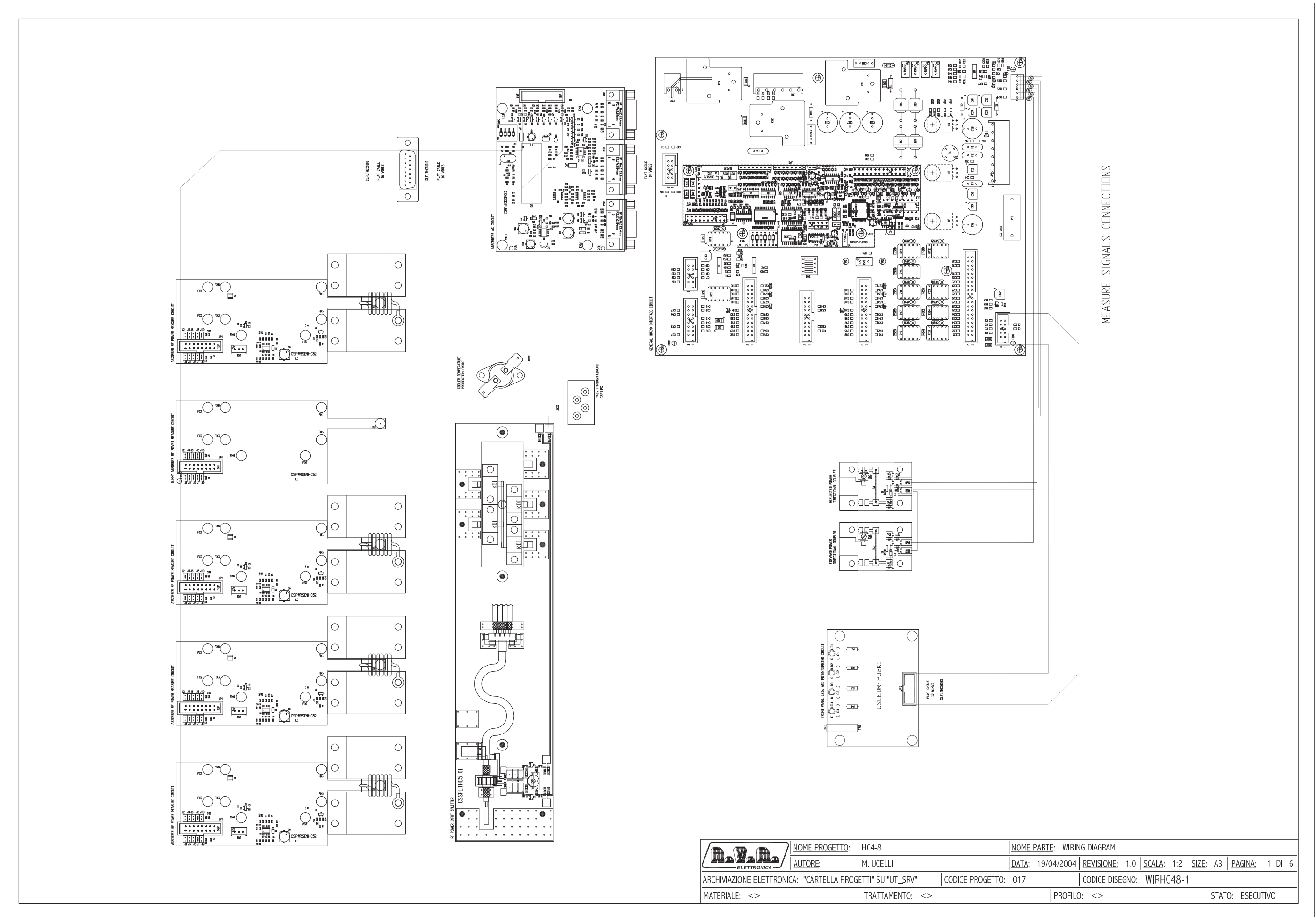

	NOME PROGETTO: HC4-8	NOME PARTE: WIRING DIAGRAM			
	AUTORE: M. UCCELLI	DATA: 19/04/2004	REVISIONE: 1.0	SCALA: 1:2	SIZE: A3
ARCHIVIAZIONE ELETTRONICA: "CARTELLA PROGETTI" SU "UT_SRV"		CODICE PROGETTO: 017	CODICE DISEGNO: WIRHC48-1		
MATERIALE: <>	TRATTAMENTO: <>	PROFILO: <>	STATO: ESECUTIVO		

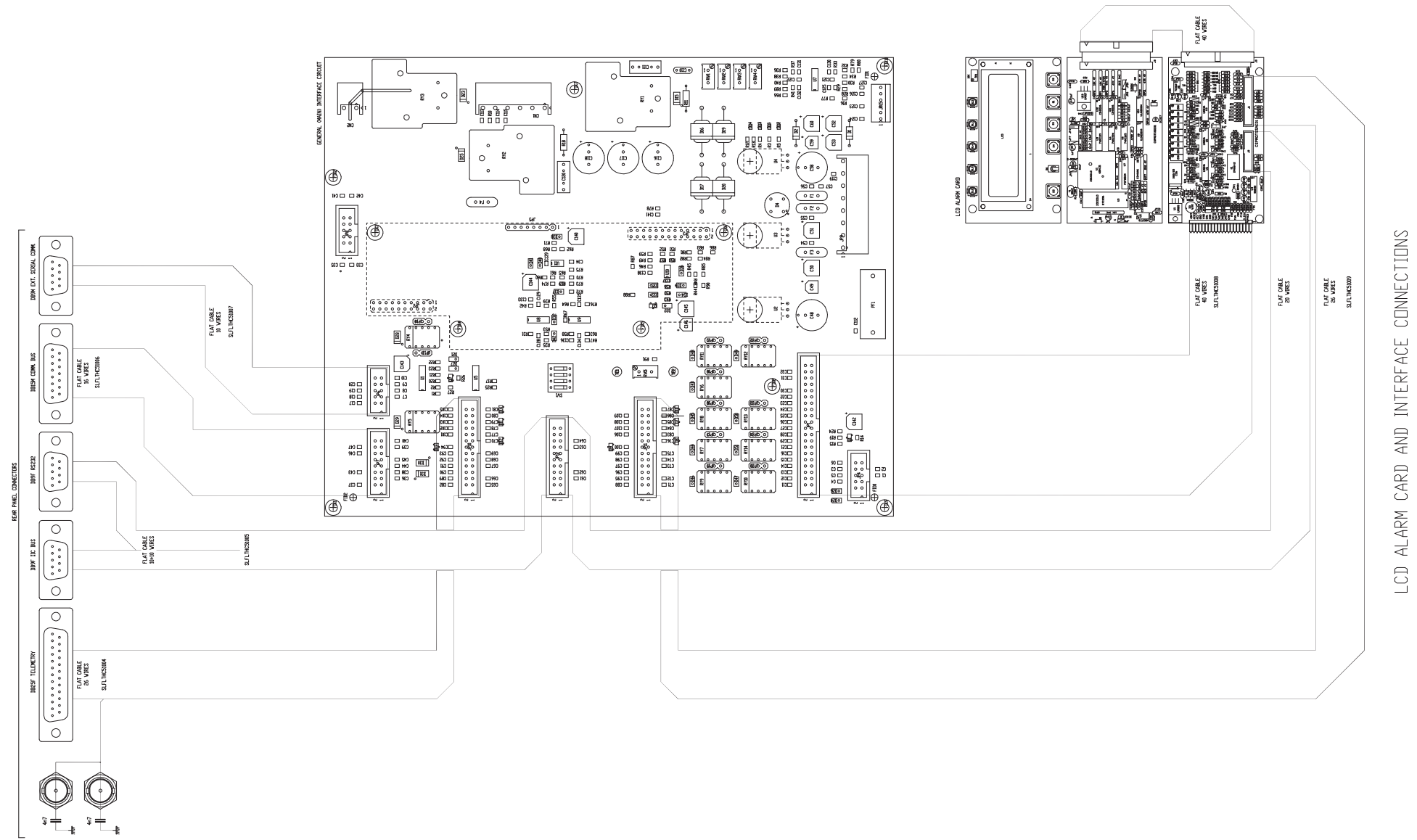

LCD ALARM CARD AND INTERFACE CONNECTIONS

	NOME PROGETTO: HC5/10	NOME PARTE: WIRING DIAGRAM			
	AUTORE: M. UCCELLI	DATA: 11/02/2004	REVISIONE: 1.0	SCALA: 1:2	SIZE: A3
ARCHIVIAZIONE ELETTRONICA: "CARTELLA PROGETTI" SU "UT_SRV"		CODICE PROGETTO: 014	CODICE DISEGNO: WIRHC510-1		
MATERIALE: <>	TRATTAMENTO: <>	PROFILO: <>	STATO: ESECUTIVO		

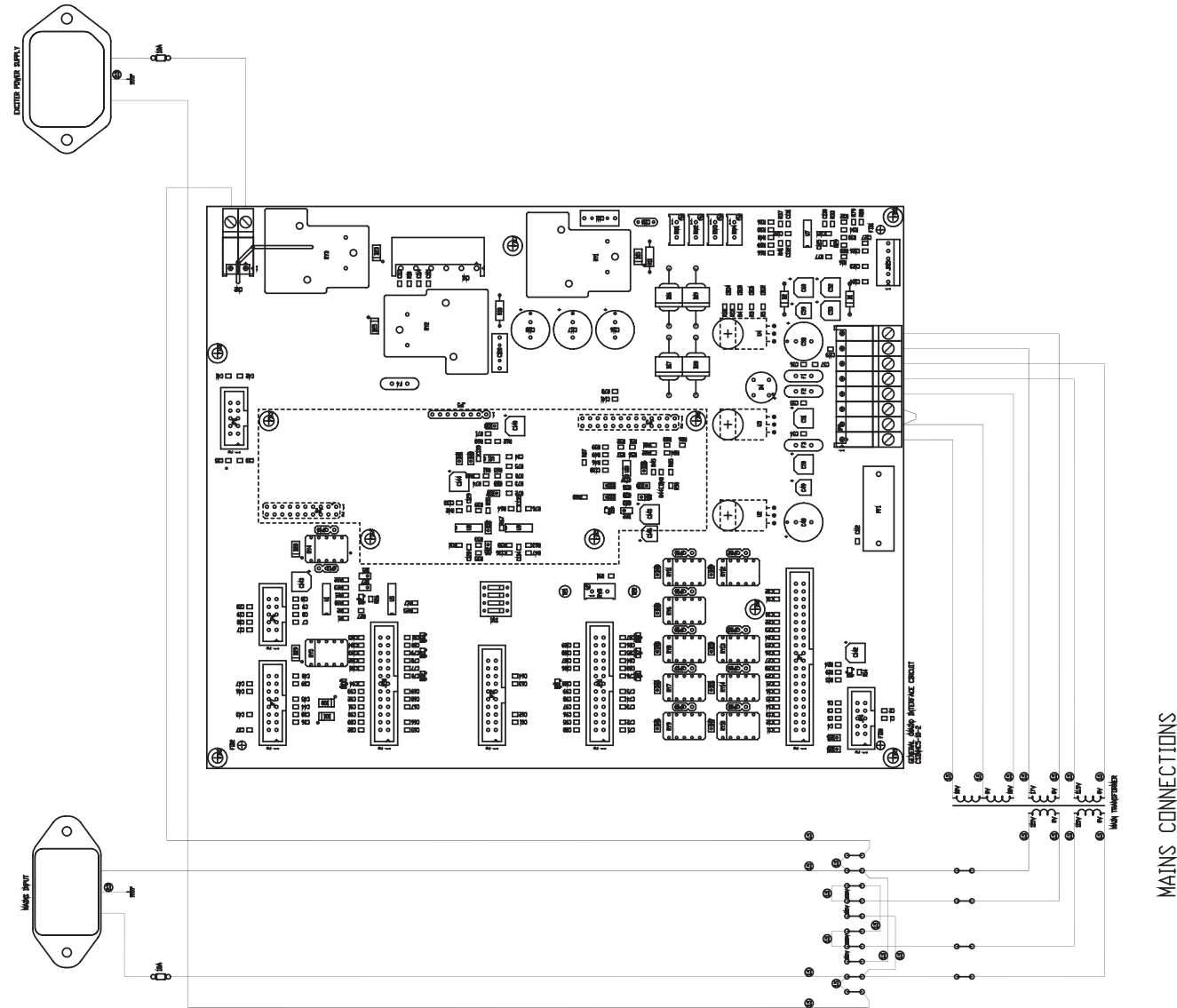

	NOME PROGETTO: HC5/10	NOME PARTE: WIRING DIAGRAM			
	AUTORE: M. UCELLI	DATA: 11/02/2004	REVISIONE: 1.0	SCALA: 1:2	SIZE: A3
ARCHIVIAZIONE ELETTRONICA: "CARTELLA PROGETTI" SU "UT_SRV"		CODICE PROGETTO: 014	CODICE DISEGNO: WIRHC510-1		
MATERIALE: <>	TRATTAMENTO: <>	PROFILO: <>	STATO: ESECUTIVO		

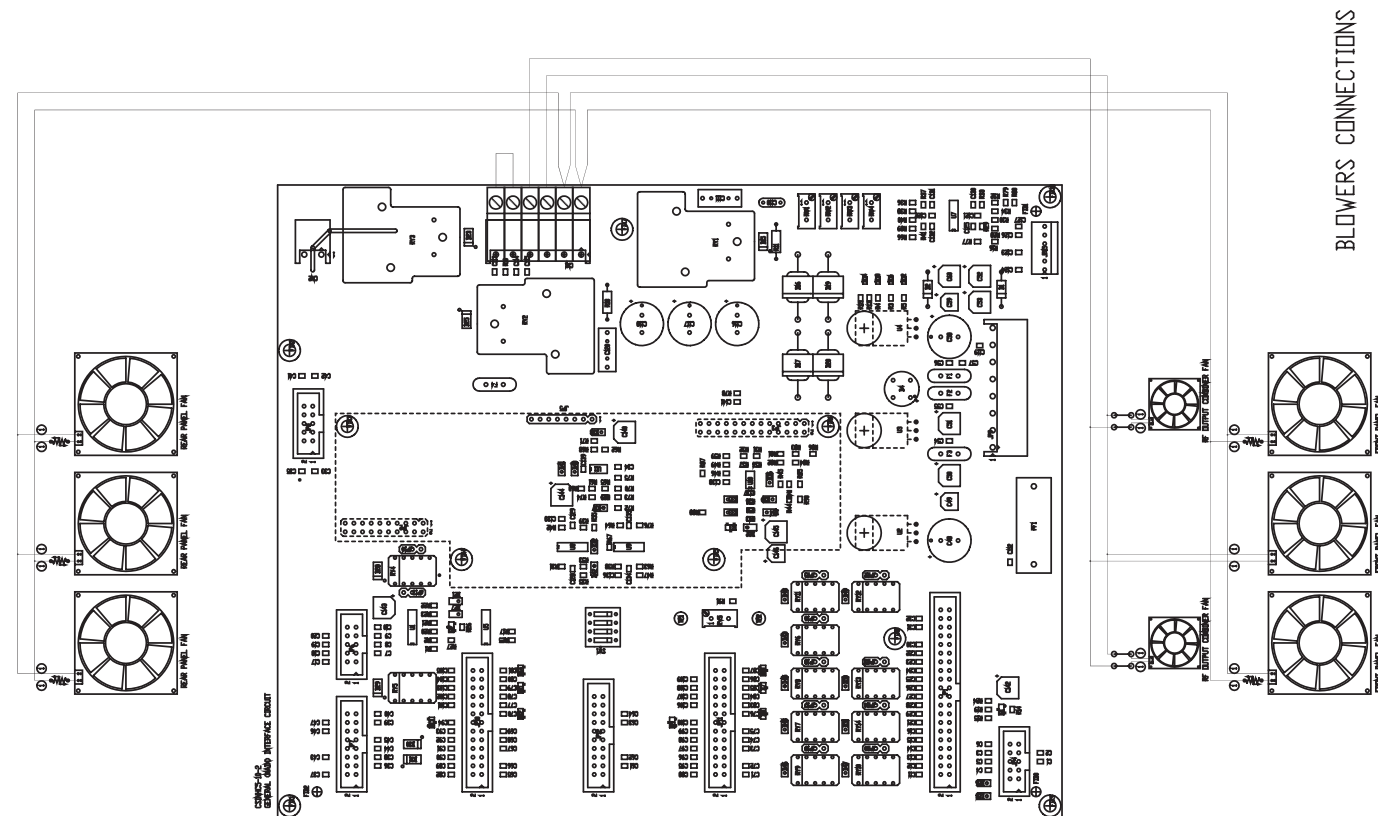

	NOME PROGETTO: HC5/10	NOME PARTE: WIRING DIAGRAM			
	AUTORE: M. UCELLI	DATA: 11/02/2004	REVISIONE: 1.0	SCALA: 1:2	SIZE: A3
ARCHIVIAZIONE ELETTRONICA: "CARTELLA PROGETTI" SU "UT_SRV"		CODICE PROGETTO: 014	CODICE DISEGNO: WIRHC510-1		
MATERIALE: <>	TRATTAMENTO: <>	PROFILO: <>	STATO: ESECUTIVO		

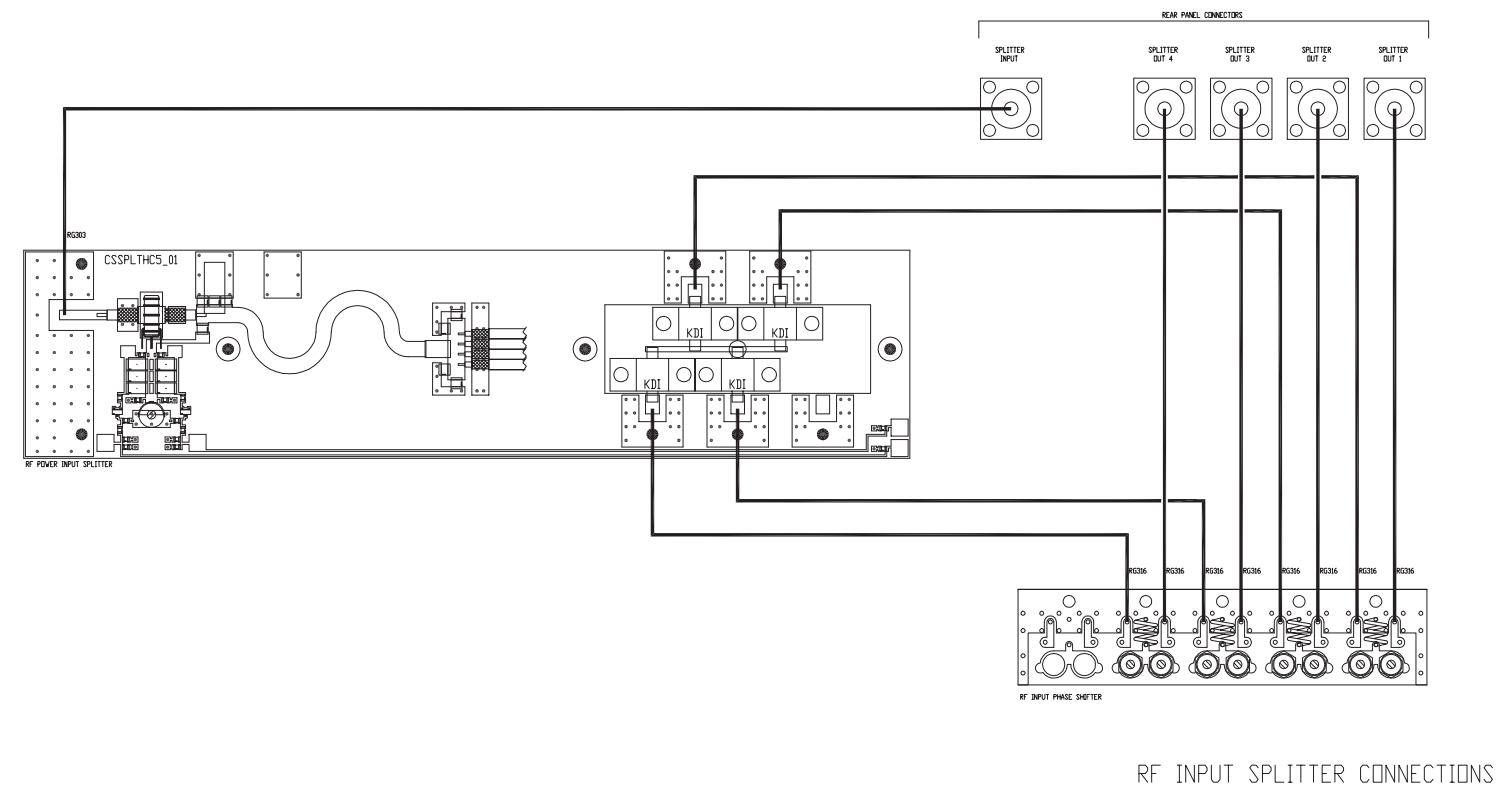

	NOME PROGETTO: HC4-8	NOME PARTE: WIRING DIAGRAM			
	AUTORE: M. UCELLI	DATA: 19/04/2004	REVISIONE: 1.0	SCALA: 1:2	SIZE: A3
ARCHIVIAZIONE ELETTRONICA: "CARTELLA PROGETTI" SU "UT_SRV"		CODICE PROGETTO: 017	CODICE DISEGNO: WIRHC510-1		
MATERIALE: <>	TRATTAMENTO: <>	PROFILO: <>	STATO: ESECUTIVO		

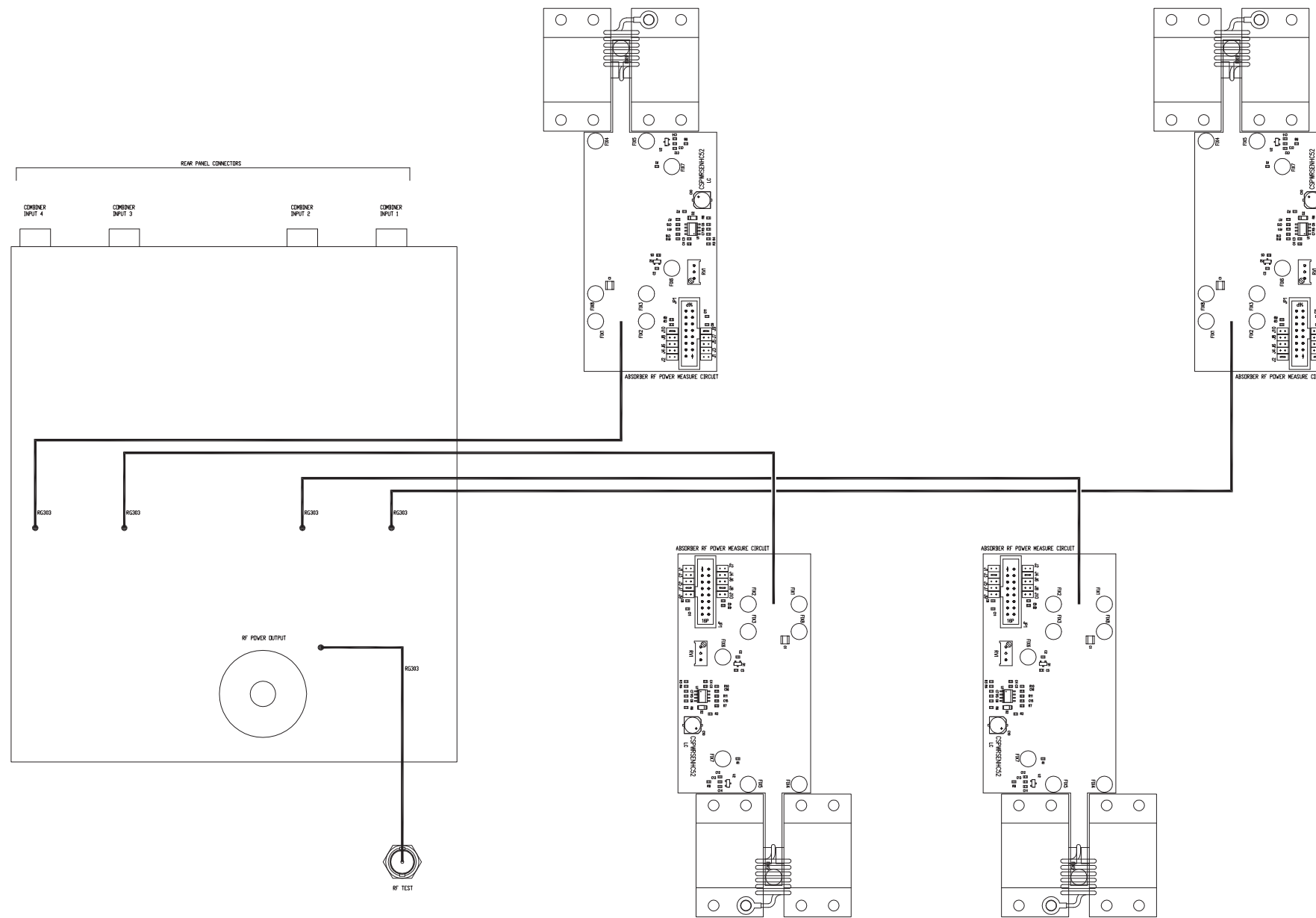

RF OUTPUT COMBINER CONNECTIONS

	NOME PROGETTO: HC4-8	NOME PARTE: WIRING DIAGRAM			
	AUTORE: M. UCCELLI	DATA: 19/04/2004	REVISIONE: 1.0	SCALA: 1:2	SIZE: A3
ARCHIVIAZIONE ELETTRONICA: "CARTELLA PROGETTI" SU "UT_SRV"	CODICE PROGETTO: 017	CODICE DISEGNO: WIRHC510-1			
MATERIALE: <>	TRATTAMENTO: <>	PROFILO: <>	STATO: ESECUTIVO		

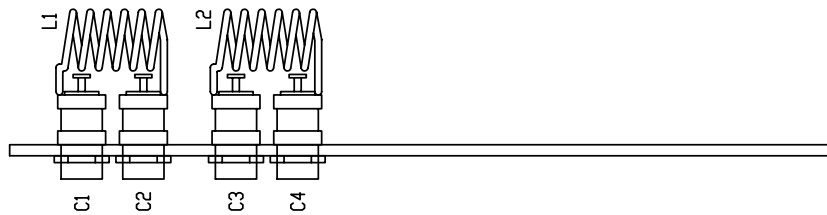
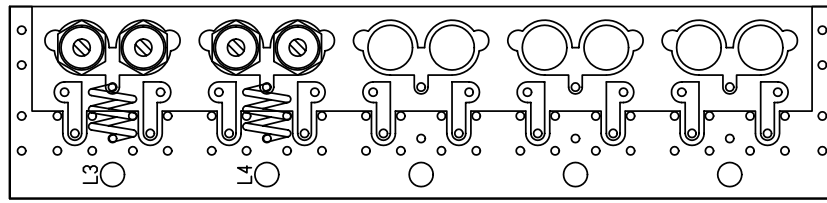
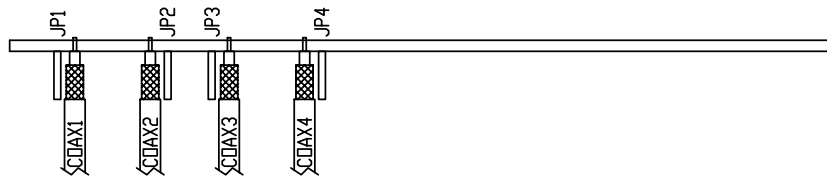
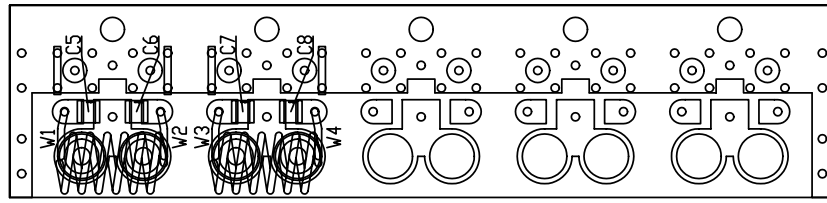
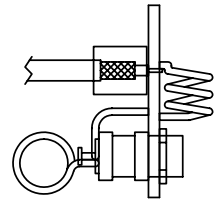

45 SPIRE FILLO DAME ANG 41 ANVOLUTE SU R5 LUNGHEZZA 6

46 SPIRE FILLO DAME ANG 41 ANVOLUTE SU R7 LUNGHEZZA 15

R.V.R. ELETTRONICA	NOME PROGETTO: HC2-4	NOME PARTE: Scheda phase shifter
AUTORE: M. UCCELLI	DATA: 19/04/2004	REVISIONE: 1.0 SCALA: 1:1 SIZE: A4 PAGINA: 1 DI 1
ARCHIVIAZIONE ELETTRONICA: "CARTELLA PROGETTI" SU "UT_SRV"	CODICE PROGETTO: 017	CODICE DISEGNO: SLPHSHHC2-02
MATERIALE: /	TRATTAMENTO: /	PROFILO: / STATO: ESECUTIVO

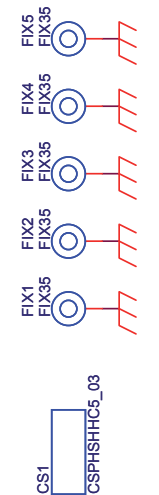
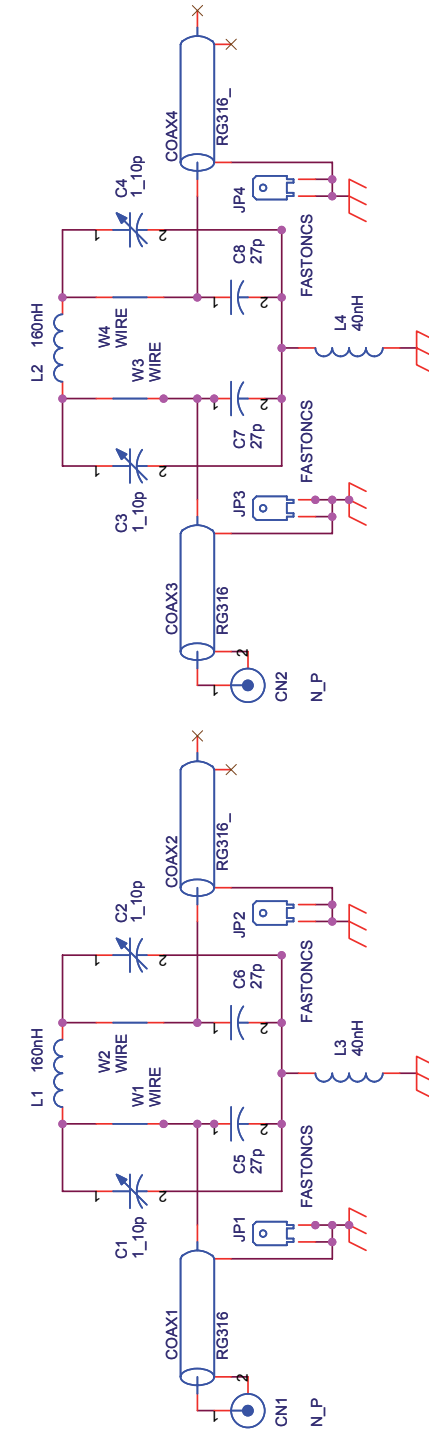

Nome Progetto: HC2-4		Pagina: 1 di 1		Size: A4	
Autore: Mauro Ucelli		Data: 19/04/04		Codice Progetto: 017	
Nome PC in Rete: \UT_SRV\Progetti		Revisione: 1.0		Nome Parte: Phase Shifter for HC2-4	
File/Caratteri: HC2-4\Esecutivi\Scemi Elettrici\SLPHSHHC2-02\Autorizzazione: SLPHSHHC2-02					

Phase Shifter for HC2-4
SLPHSHHC2-02
Revision: 1.0
HC2-4
Mauro Ucelli
#####

Item	Quantity	Reference	Part
1	2	CN1,CN2	N_P
2	2	COAX1,COAX3	RG316
3	2	COAX2,COAX4	RG316_
4	1	CS1	CSPHSHHC5_03
5	4	C1,C2,C3,C4	1_10p
6	4	C5,C6,C7,C8	27p
7	5	FIX1,FIX2,FIX3,FIX4,FIX5	FIX35
8	4	JP1,JP2,JP3,JP4	FASTONCS
9	2	L1,L2	160nH
10	2	L3,L4	40nH
11	4	W1,W2,W3,W4	WIRE

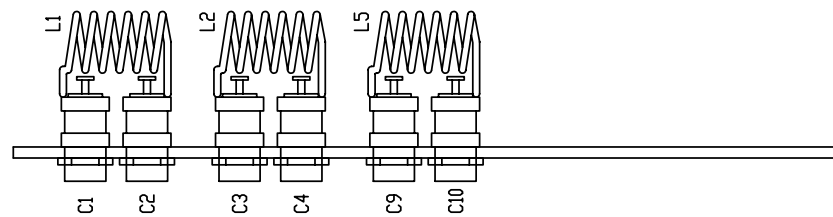
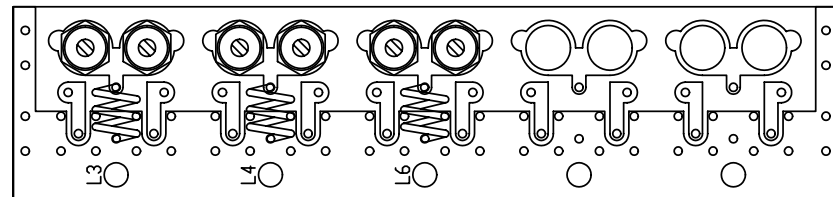
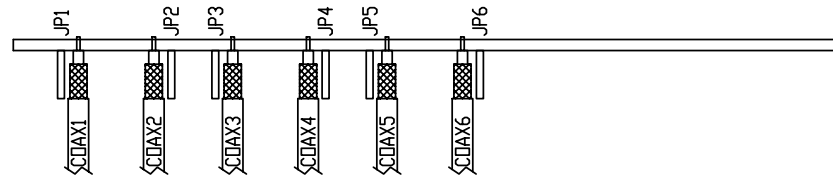
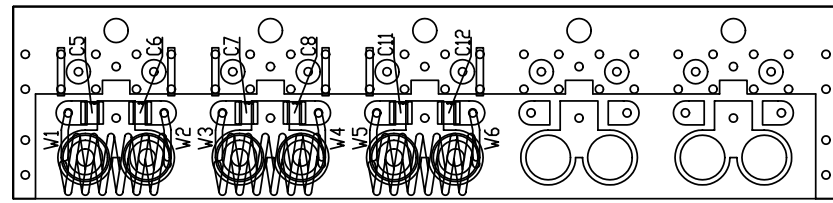
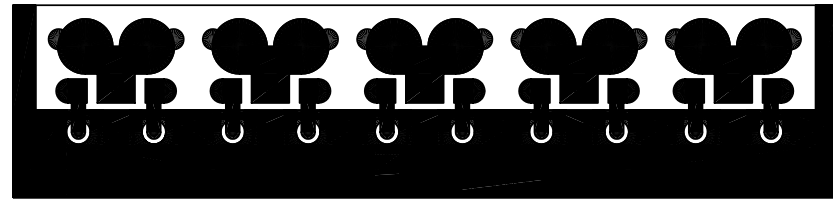
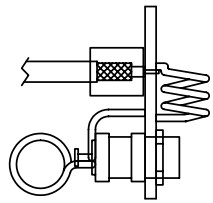

43 SPIRE FILLO BIANCO ARG #4 AVVOLTE SU #5 LUNGHEZZA 6

46 SPIRE FILLO BIANCO ARG #4 AVVOLTE SU #7 LUNGHEZZA 15

	NOME PROGETTO: HC3-6	NOME PARTE: Scheda phase shifter			
	AUTORE: M. UCCELLI	DATA: 19/04/2004	REVISIONE: 1.0	SCALA: 1:1	SIZE: A4
ARCHIVIAZIONE ELETTRONICA: "CARTELLA PROGETTI" SU "UT_SRV"	CODICE PROGETTO: 017	CODICE DISEGNO: SLPHSHHC3-02			
MATERIALE: /	TRATTAMENTO: /	PROFILO: /	STATO: ESECUTIVO		

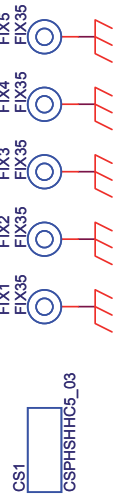
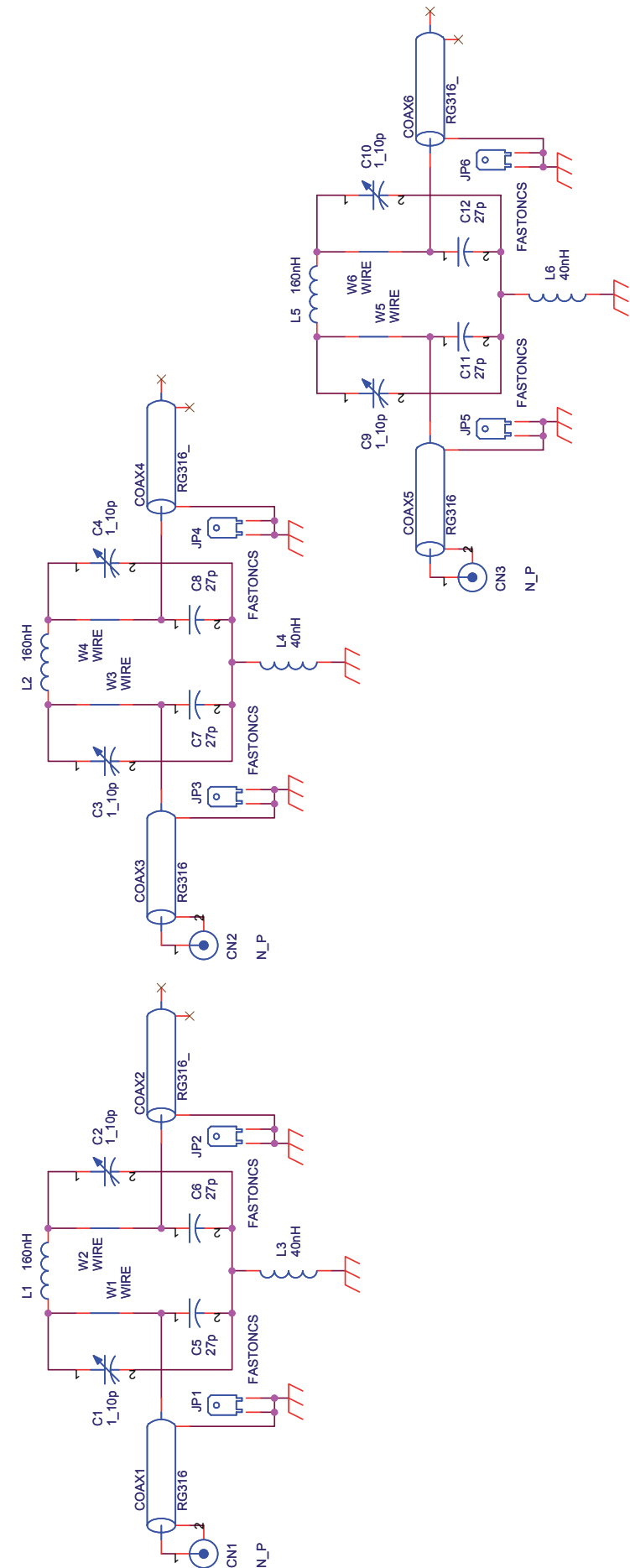

NOME PROGETTO: HC3-6	Pagina: 1 di 1	Size: A4
AUTORE: Mauro Ucelli	DATA: 19/04/04	Codice Progetto: 017
NOME PC in Rete: WUT_SRV\Progetti	REVISIONE: 1.0	NOME PARTE: Phase Shifter for HC3-6
File/Carrella: Esecutio\Schemi Elettrici\SLPHSHHC3-02	Autorizzazione:	Codice: SLPHSHHC3-02

Phase Shifter for HC3-6 Revised: Tuesday, March 23, 2004
SLPHSHHC3-02 Revision: 1.0

HC3-6
HC3-6

Mauro Ucelli

Item	Quantity	Reference	Part	Description
1	3	CN1, CN2, CN3	N_P	Conn. N da pannello per cavo RG316
2	3	COAX1, COAX3, COAX5	RG316	Cavo coax 50H RG316
3	3	COAX2, COAX4, COAX6	RG316	Cavo coax 50H RG316 (595mm)
4	1	CS1	CSPHSHHC5_03	Circuito stampato
5	6	C1, C2, C3, C4, C9, C10	1_10p	Comp. var. ad aria Tekelek 6mm
6	6	C5, C6, C7, C8, C11, C12	27p	Cond. SMD 1212 HQ
7	5	FIX1, FIX2, FIX3, FIX4, FIX5	FIX35	Foro fissaggio 3.5mm
8	6	JP1, JP2, JP3, JP4, JP5, JP6	FASTONCS	Faston da CS p. 5.08
9	3	L1, L2, L5	160nH	Induttanza cilindrica
10	3	L3, L4, L6	40nH	Induttanza cilindrica
11	6	W1, W2, W3, W4, W5, W6	WIRE	Filo a saldare

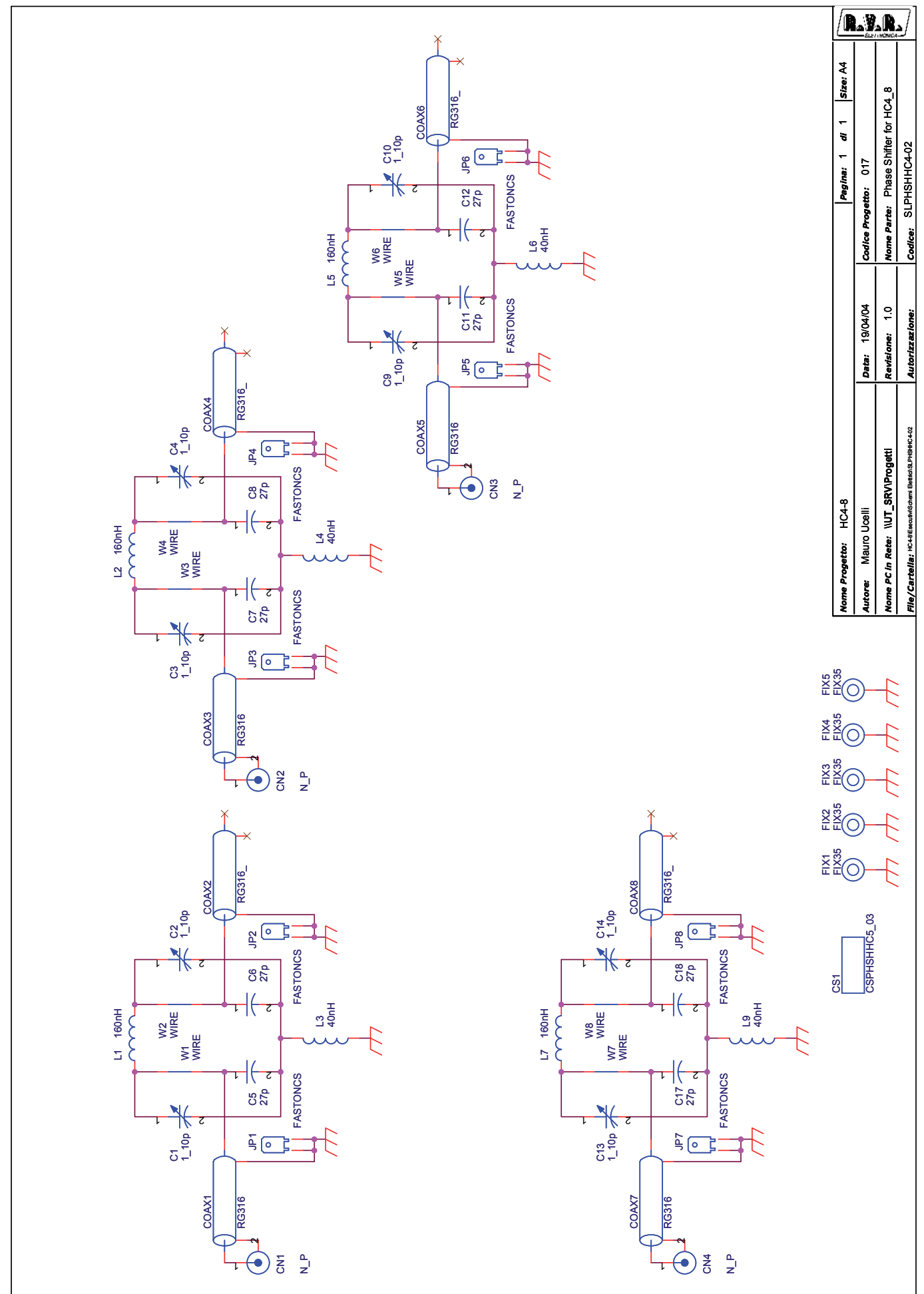
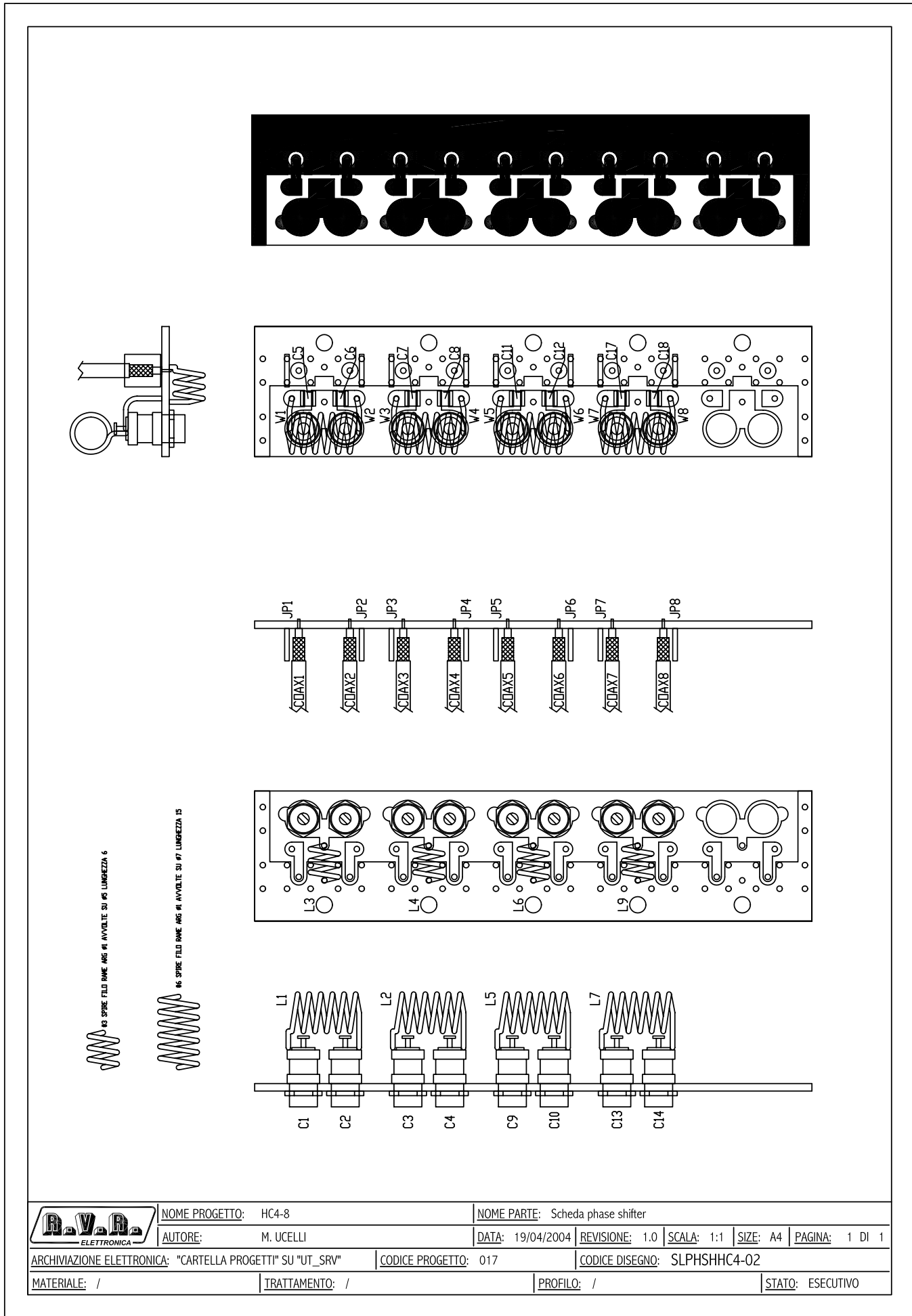

Phase Shifter for HC4_8 Revised: Tuesday, April 27, 2004

SLPHSHHC4-02 Revision: 1.0

HC4-8

017

Mauro Ucelli

Item	Quantity	Reference	Part	Description
1	4	CN1, CN2, CN3, CN4	N_P	Conn. N da pannello per cavo RG316
2	4	COAX1, COAX3, COAX5, COAX7	RG316	Cavo coax
3	4	COAX2, COAX4, COAX6, COAX8	RG316_	Cavo coax
4	1	CS1	CSPHSHHC5_03	Circuito stampato
5	8	C1, C2, C3, C4, C9, C10, C13, C14	1_10p	Comp. var. ad aria Tekelek 6mm
6	8	C5, C6, C7, C8, C11, C12, C17, C18	27p	Cond. SMD 1212 HQ
7	5	FIX1, FIX2, FIX3, FIX4, FIX5	FIX35	Foro fissaggio 3.5mm
8	8	JP1, JP2, JP3, JP4, JP5, JP6, JP7, JP8	FASTONCS	Faston da CS p. 5.08
9	4	L1, L2, L5, L7	160nH	Induttanza cilindrica
10	4	L3, L4, L6, L9	40nH	Induttanza cilindrica
11	8	W1, W2, W3, W4, W5, W6, W7, W8	WIRE	Filo a saldare

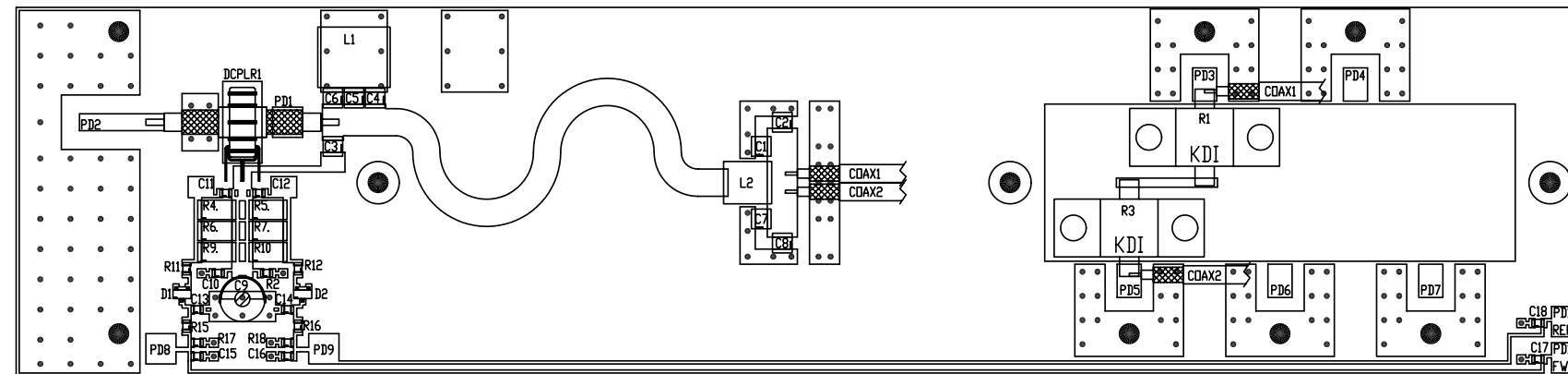

	NOME PROGETTO: HC2-4	NOME PARTE: SCHEDA SPLITTER			
	AUTORE: M. UCELLI	DATA: 19/04/2004	REVISIONE: 1.0	SCALA: 1:1	SIZE: A3
ARCHIVIAZIONE ELETTRONICA: "CARTELLA PROGETTI" SU "UT_SRV"	CODICE PROGETTO: 017	CODICE DISEGNO: SLSPLTHC2-01			
MATERIALE: /	TRATTAMENTO: /	PROFILO: /	STATO: ESECUTIVO		

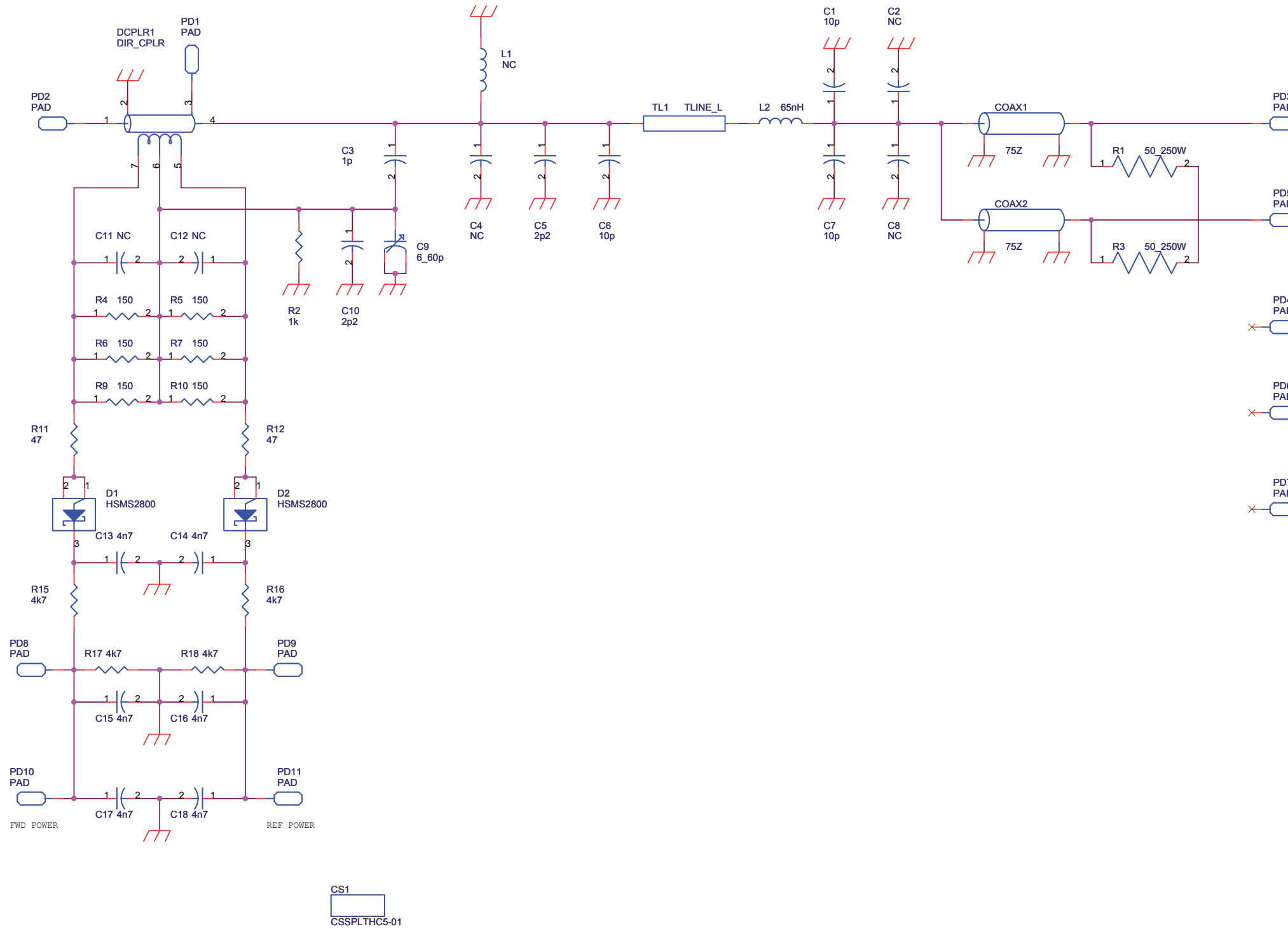

Nome Progetto: HC2-4		Pagina: 1 di 1	Size: A3
Autore: Mauro Ucelli	Data: 19/04/04	Codice Progetto: 017	
Nome PC in Rete: \WJT_SRV\Progetti	Revisione: 1.0	Nome Parte: 2 Ways Input Splitter	
File/Cartella:	Autorizzazione:	Codice: SLSPLTHC2-01	

2 Ways Input Splitter
SLSPLTHC2-01
Revision: 1.0
HC2-4
Mauro Ucelli
15/03/2004

Item	Quantity	Reference	Part	Description
1	2	COAX1,COAX2	75Z	Cavo coax 75 Ohm RG179 lung 530mm da un fine calza all'altro.
2	1	CS1	CSSPLTHC5-01	Circuito stampato
3	3	C1,C6,C7	10p	Cond. SMD 1212 HQ
4	3	C2,C4,C8	NC	Cond. SMD 1212 HQ
5	1	C3	1p	Cond. SMD 1212 HQ
6	1	C5	2p2	Cond. SMD 1212 HQ
7	1	C9	6_60p	Comp. ceramico dia. 7mm
8	1	C10	2p2	Cond. SMD 0805
9	2	C11,C12	NC	Cond. SMD 0805
10	6	C13,C14,C15,C16,C17,C18	4n7	Cond. SMD 0805
11	1	DCPLR1	DIR_CPLR	Accopp. direz.
12	2	D1,D2	HSMS2800	Diodo Shottky SOT23
13	1	L1	NC	Induttanza cilindrica
14	1	L2	65nH	4 Spire filo rame Arg. D.1 avvolte su D.6 lung.10 (BOB01020005A)
15	11	PD1,PD2,PD3,PD4,PD5,PD6, PD7,PD8,PD9,PD10,PD11	PAD	
16	2	R1,R3	50_250W	Resistenza KDI 2 fix 50 Ohm 250W
17	1	R2	1k	Res. SMD 0805
18	6	R4,R5,R6,R7,R9,R10	150	Res. SMD 2512
19	2	R11,R12	47	Res. SMD 0805
20	4	R15,R16,R17,R18	4k7	Res. SMD 0805
21	1	TL1	TLINE_L	Linea strip CS

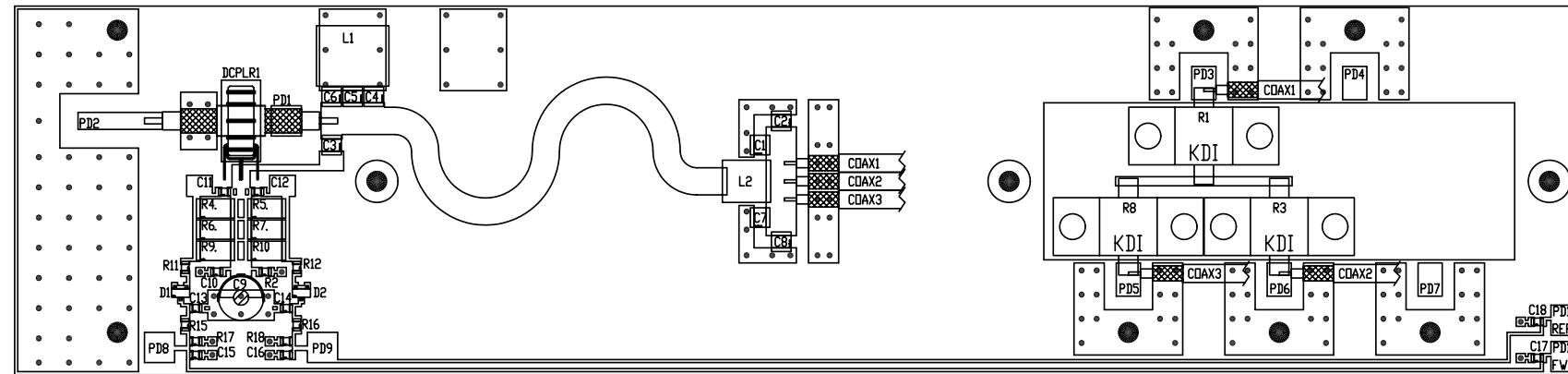

	NOME PROGETTO: HC3-6	NOME PARTE: SCHEDA SPLITTER PER HC3-6			
	AUTORE: M. UCELLI	DATA: 19/04/2004	REVISIONE: 1.0	SCALA: 1:1	SIZE: A3
ARCHIVIAZIONE ELETTRONICA: "CARTELLA PROGETTI" SU "UT_SRV"		CODICE PROGETTO: 017	CODICE DISEGNO: SLSPLTHC3-01		
MATERIALE: /	TRATTAMENTO: /	PROFILO: /	STATO: ESECUTIVO		

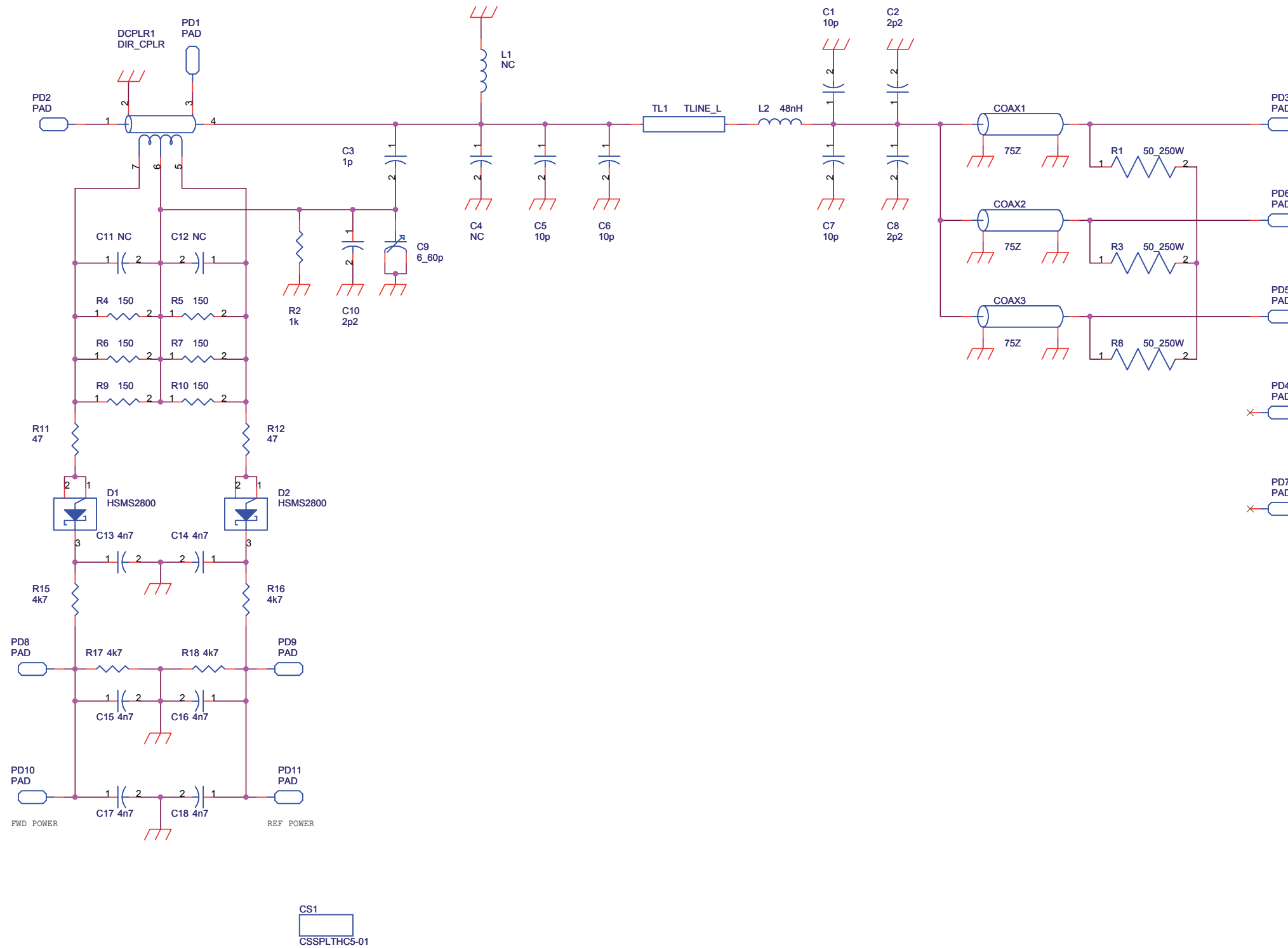

Nome Progetto: HC3-6		Pagina: 1 di 1		Size: A3
Autore: Mauro Ucelli	Data: 19/04/04	Codice Progetto: HC3-6		
Nome PC in Rete: IUT_SRV\Progetti	Revisione: 1.0	Nome Parte: 3 Ways Input Splitter		
File/Cartella:	Autorizzazione:	Codice: SLSPLTHC3-01		

3 Ways Input Splitter Revised: Monday, March 15, 2004
SLSPLTHC3-01 Revision: 1.0
HC3-6
HC3-6

Mauro Ucelli

Item	Quantity	Reference	Part	Description
1	3	COAX1, COAX2, COAX3	75Z	Cavo coax
2	1	CS1	CSSPLTHC5-01	Circuito stampato
3	4	C1, C5, C6, C7	10p	Cond. SMD 1212 HQ
4	2	C8, C2	2p2	Cond. SMD 1212 HQ
5	1	C3	1p	Cond. SMD 1212 HQ
6	1	C4	NC	Cond. SMD 1212 HQ
7	1	C9	6_60p	Comp. ceramico dia. 7mm
8	1	C10	2p2	Cond. SMD 0805
9	2	C12, C11	NC	Cond. SMD 0805
10	6	C13, C14, C15, C16, C17, C18	4n7	Cond. SMD 0805
11	1	DCPLR1	DIR_CPLR	Accopp. direz.
12	2	D1, D2	HSMS2800	Diode Shottky SOT23
13	1	L1	NC	Induttanza cilindrica
14	1	L2	48nH	Induttanza cilindrica
15	11	PD1, PD2, PD3, PD4, PD5, PD6, PD7, PD8, PD9, PD10, PD11	PAD	
16	3	R1, R3, R8	50_250W	Resistenza KDI 2 fix
17	1	R2	1k	Res. SMD 0805
18	6	R4, R5, R6, R7, R9, R10	150	Res. SMD 2512
19	2	R12, R11	47	Res. SMD 0805
20	4	R15, R16, R17, R18	4k7	Res. SMD 0805
21	1	TL1	TLINE_L	Linea strip CS

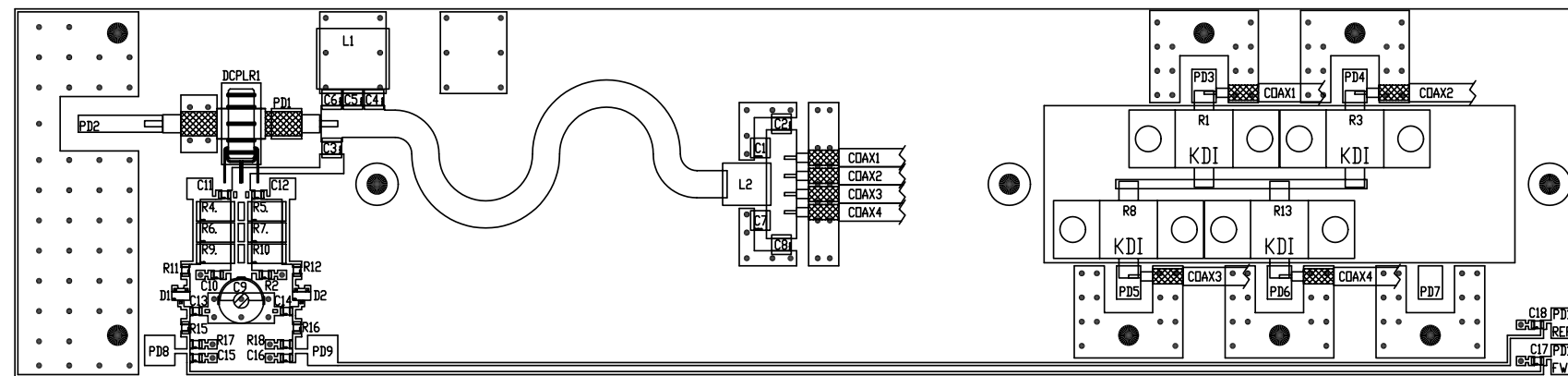

	NOME PROGETTO: HC4-8	NOME PARTE: SCHEDA SPLITTER			
	AUTORE: M. UCELLI	DATA: 19/04/2004	REVISIONE: 1.0	SCALA: 1:1	SIZE: A3
ARCHIVIAZIONE ELETTRONICA: "CARTELLA PROGETTI" SU "UT_SRV"	CODICE PROGETTO: 017	CODICE DISEGNO: SLSPLTHC4-01			
MATERIALE: /	TRATTAMENTO: /	PROFILO: /	STATO: ESECUTIVO		

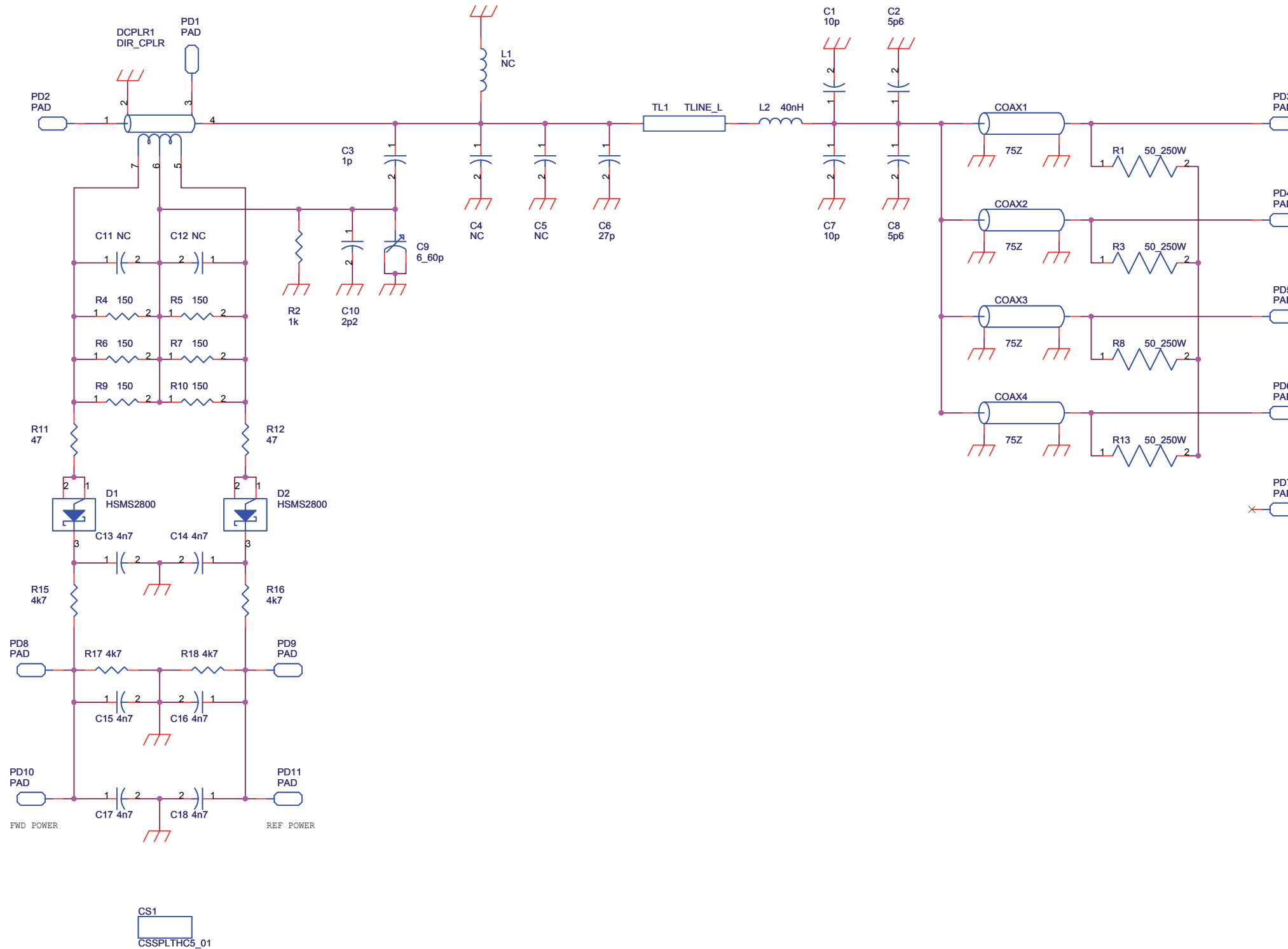

Nome Progetto: HC4-8		Pagina: 1 di 1	Size: A3
Autore: Mauro Ucelli	Data: 19/04/04	Codice Progetto: 017	
Nome PC in Rete: \WUT_SRVVProgetti	Revisione: 1.0	Nome Parte: 4 Ways Input Splitter	
File/ Cartella:	Autorizzazione:	Codice: SLSPLTHC4-01	

4 Ways Input Splitter Revised: Monday, March 15, 2004

SLSPLTHC4-01 Revision: 1.0

HC4-8

HC4-8

Mauro Ucelli

Item	Quantity	Reference	Part	Description
1	4	COAX1, COAX2, COAX3, COAX4	75Z	Cavo coax
2	1	CS1	CSSPLTHC5_01	Circuito stampato
3	2	C7, C1	10p	Cond. SMD 1212 HQ
4	2	C8, C2	5p6	Cond. SMD 1212 HQ
5	1	C3	1p	Cond. SMD 1212 HQ
6	2	C4, C5	NC	Cond. SMD 1212 HQ
7	1	C6	27p	Cond. SMD 1212 HQ
8	1	C9	6_60p	Comp. ceramico dia. 7mm
9	1	C10	2p2	Cond. SMD 0805
10	2	C11, C12	NC	Cond. SMD 0805
11	6	C13, C14, C15, C16, C17, C18	4n7	Cond. SMD 0805
12	1	DCPLR1	DIR_CPLR	Accopp. direz.
13	2	D1, D2	HSMS2800	Diodo Shottky SOT23
14	1	L1	NC	Induttanza cilindrica
15	1	L2	40nH	Induttanza cilindrica
16	11	PD1, PD2, PD3, PD4, PD5, PD6, PD7, PD8, PD9, PD10, PD11	PAD	
17	4	R1, R3, R8, R13	50_250W	Resistenza KDI 2 fix
18	1	R2	1k	Res. SMD 0805
19	6	R4, R5, R6, R7, R9, R10	150	Res. SMD 2512
20	2	R11, R12	47	Res. SMD 0805
21	4	R15, R16, R17, R18	4k7	Res. SMD 0805
22	1	TL1	TLINE_L	Linea strip CS

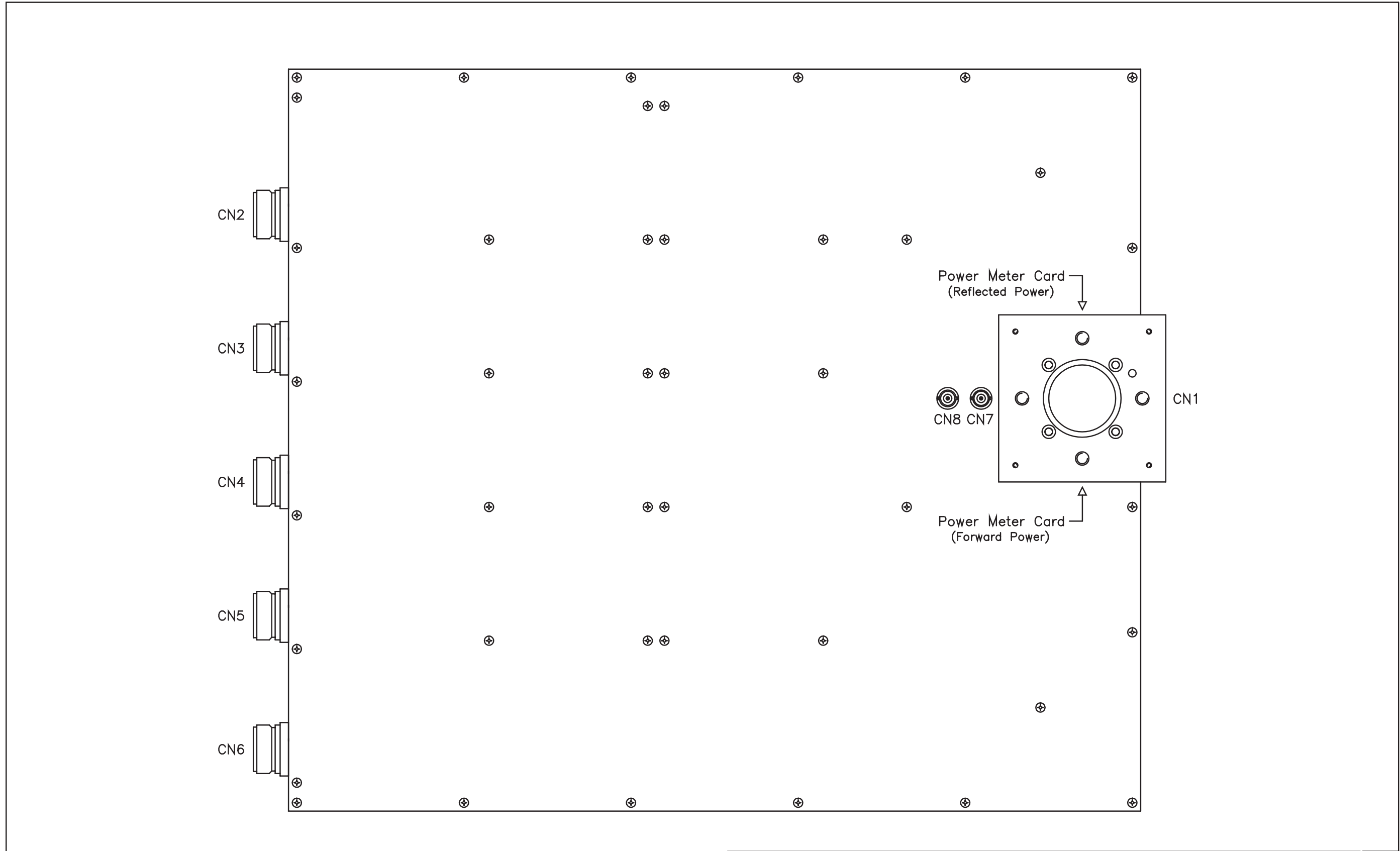

Nome Progetto: HC5 LCD		Pagina: 1 di 1		Size: A3
Autore: Ufficio Tecnico		Data: 17/06/03	Codice Progetto: PFHC5/5LCD	
Nome PC in Rete: \\UT_SRV\PROGETTI		Revisione: 2.0	Nome Parte: POWER COMBINER LAYOUT	
File/Cartella: MANUALI\HC5LCD\SLCMB1HC5LCD\LAYCPL.DWG		Autorizzazione:	Codice: SLCMB1HC5LCD	
Scala: 1:1,5	Materiale: /	Trattamento: /	Profilo: /	



ARCHIVIAZIONE ELETTRONICA: "CARTELLA PROGETTI" SU "UT_SRV"		NOME PROGETTO: HC5-10	
MATERIALE: FR4-74 1.6mm Cu 35um		AUTORE: GP - Rev.: J. Berti	
TRATTAMENTO: STANDARD COSTRUTTORE		GP - Rev.: J. Berti	
CODICE PROGETTO: 014		NOME PARTE: Analogic Section Component Layout	
DATA: 14/03/2007		REVISIONE: 3.1	
CODICE DISEGNO: PROTPJ-HCLCD		SCALA: 1:1	
STATO: ESECUTIVO		SIZE: A4	
		PAGINA: 1 DI 1	

PIANO DI MONTAGGIO CSPROTSSAE02 R3

DARE UN PUNTO CON LA COLLA A CALDO

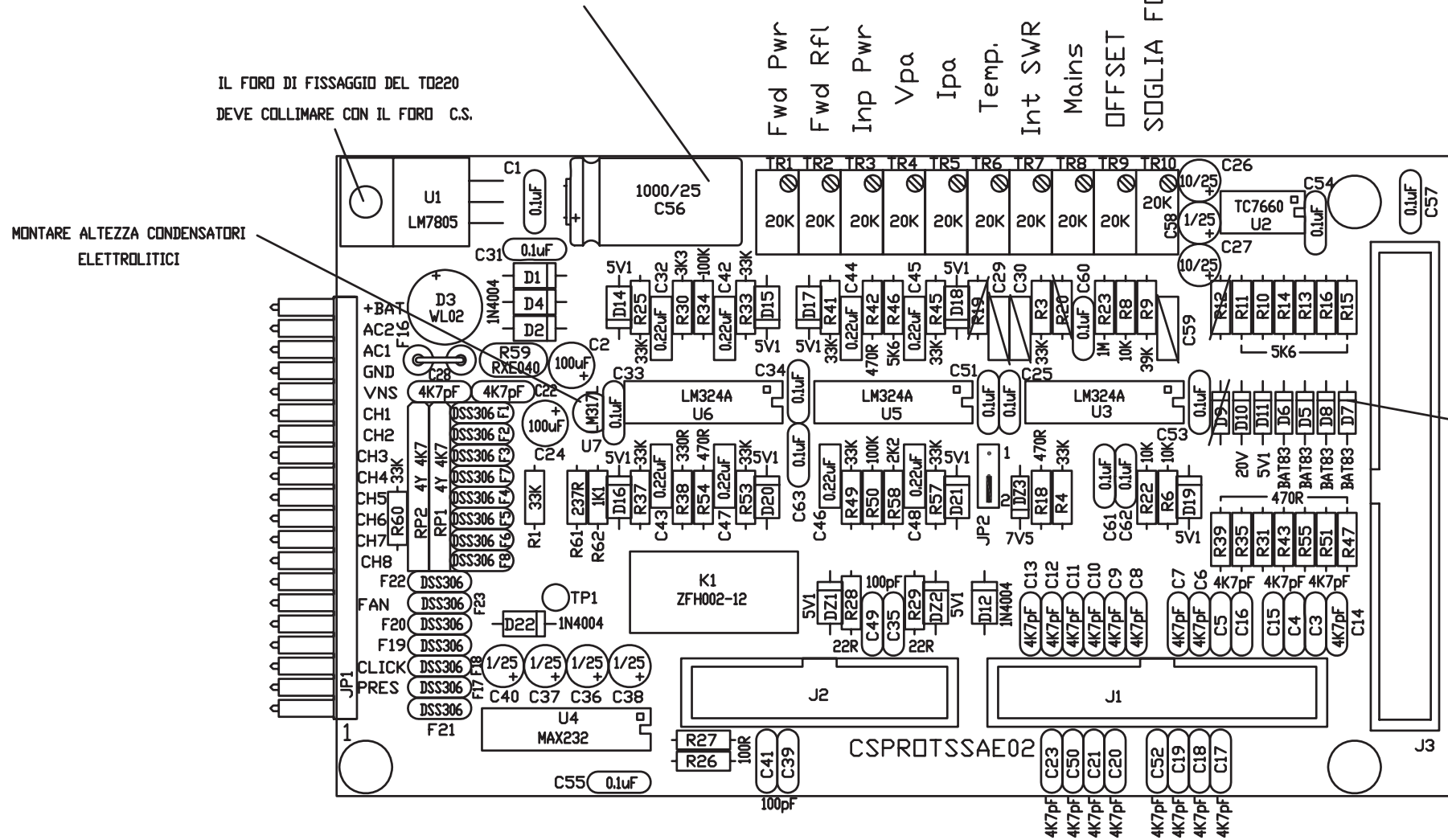

NOTE: REL 3

AGGIUNGERE UN RESISTENZA DA 10K SUL LS IN PD3

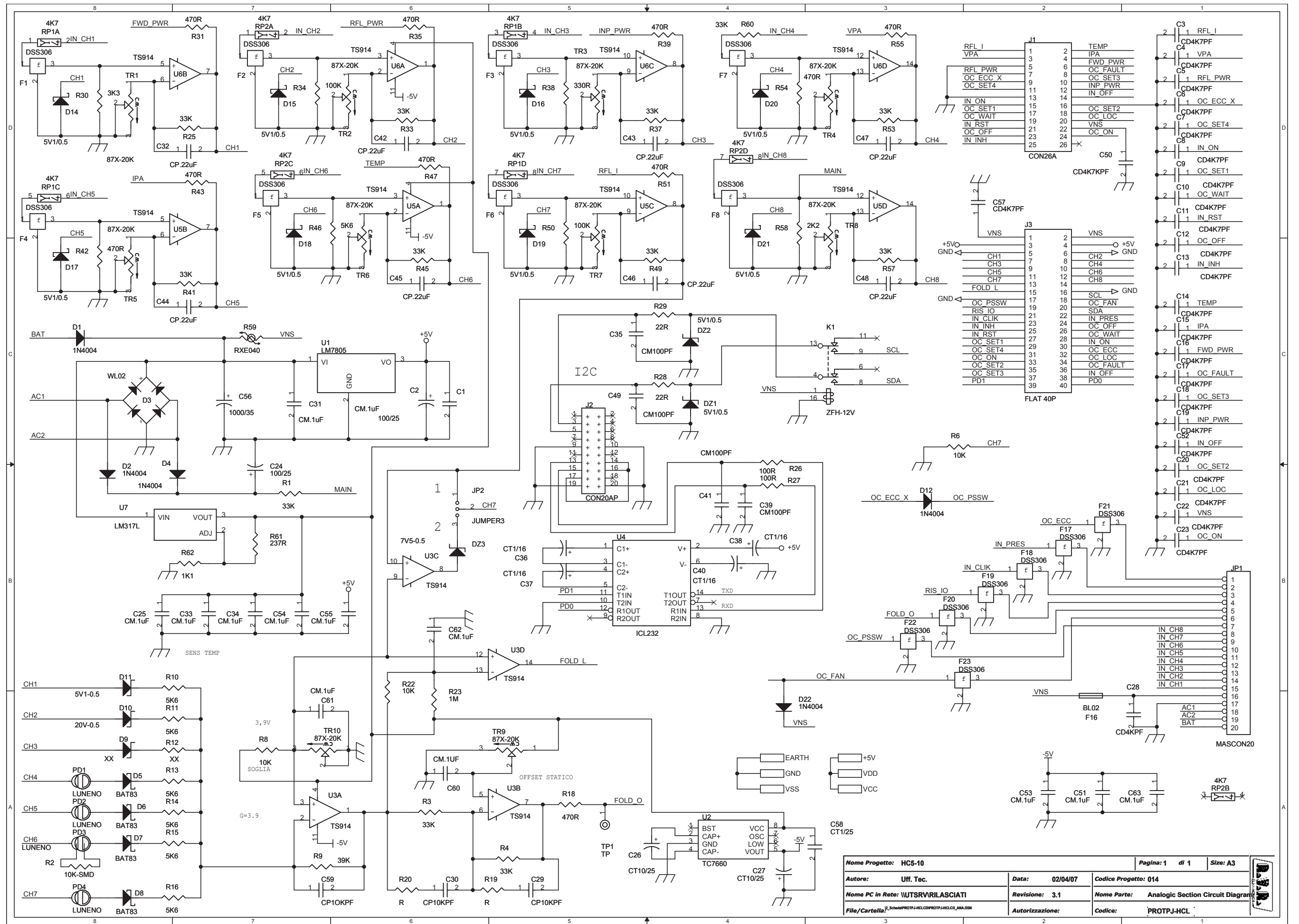

Nome Progetto: HC5-10		Pagina: 1 di 1		Size: A3
Autore: Uff. Tec.		Data: 02/04/07		Codice Progetto: 014
Nome PC in Rete: \UTSRV\ILASCIATI		Revisione: 3.1		Nome Parte: Analogic Section Circuit Diagram
File/Cartella: \\3046\PROTPJ\HCL\PROTPJ\HCL_CD_ANALOG		Autorizzazione:		Codice: PROTPJ-HCL

PROTPJ-HCL

Revised: Thursday, January 08, 2009
Revision:

Item	Quantity	Reference	Part
1	13	C1, C25, C31, C33, C34, C51, C53, C54, C55, C60, C61, C62, C63	CM.1uF
2	2	C2, C24	100/25
3	23	C3, C4, C5, C6, C7, C8, C9, C10, C11, C12, C13, C14, C15, C16, C17, C18, C19, C20, C21, C22, C23, C52, C57	CD4K7PF
4	2	C26, C27	CT10/25
5	1	C28	CD4KPF
6	2	C29, C30	CP10KPF
7	8	C32, C42, C43, C44, C45, C46, C47, C48	CP.22uF
8	4	C35, C39, C41, C49	CM100PF
9	4	C36, C37, C38, C40	CT1/16
10	1	C50	CD4K7KPF
11	1	C56	1000/35
12	1	C58	CT1/25
13	1	C59	CP10KPF
14	10	DZ1, DZ2, D14, D15, D16, D17, D18, D19, D20, D21	5V1/0.5
15	1	DZ3	7V5-0.5
16	5	D1, D2, D4, D12, D22	1N4004
17	1	D3	WL02
18	4	D5, D6, D7, D8	BAT83
19	2	D9, R12	XX
20	1	D10	20V-0.5
21	1	D11	5V1-0.5
22	15	F1, F2, F3, F4, F5, F6, F7, F8, F17, F18, F19, F20, F21, F22, F23	DSS306
23	1	F16	BL02
24	1	JP1	MASCON20
25	1	JP2	JUMPER3
26	1	J1	CON26A
27	1	J2	CON20AP
28	1	J3	FLAT 40P
29	1	K1	ZFH-12V
30	4	PD1, PD2, PD3, PD4	LUNENO
31	2	RP1, RP2	4K7
32	12	R1, R3, R4, R25, R33, R37, R41, R45, R49, R53, R57, R60	33K
33	1	R2	10K-SMD
34	3	R6, R8, R22	10K
35	1	R9	39K
36	7	R10, R11, R13, R14, R15, R16, R46	5K6
37	10	R18, R31, R35, R39, R42, R43, R47, R51, R54, R55	470R
38	2	R19, R20	R
39	1	R23	1M
40	2	R26, R27	100R
41	2	R28, R29	22R
42	1	R30	3K3
43	2	R34, R50	100K
44	1	R38	330R
45	1	R58	2K2
46	1	R59	RXE040
47	1	R61	237R
48	1	R62	1K1
49	1	TP1	TP
50	10	TR1, TR2, TR3, TR4, TR5, TR6, TR7, TR8, TR9, TR10	87X-20K
51	1	U1	LM7805
52	1	U2	TC7660
53	3	U3, U5, U6	TS914
54	1	U4	ICL232
55	1	U7	LM317L

Revised: Thursday, January 08, 2009
Revision:

Item	Quantity	Reference	Part
1	13	C1, C25, C31, C33, C34, C51, C53, C54, C55, C60, C61, C62, C63	CM.1uF
2	2	C2, C24	100/25
3	23	C3, C4, C5, C6, C7, C8, C9, C10, C11, C12, C13, C14, C15, C16, C17, C18, C19, C20, C21, C22, C23, C52, C57	CD4K7PF
4	2	C26, C27	CT10/25
5	1	C28	CD4KPF
6	2	C29, C30	CP10KPF
7	8	C32, C42, C43, C44, C45, C46, C47, C48	CP.22uF
8	4	C35, C39, C41, C49	CM100PF
9	4	C36, C37, C38, C40	CT1/16
10	1	C50	CD4K7KPF
11	1	C56	1000/35
12	1	C58	CT1/25
13	1	C59	CP10KPF
14	10	DZ1, DZ2, D14, D15, D16, D17, D18, D19, D20, D21	5V1/0.5
15	1	DZ3	7V5-0.5
16	5	D1, D2, D4, D12, D22	1N4004
17	1	D3	WL02
18	4	D5, D6, D7, D8	BAT83
19	2	D9, R12	XX
20	1	D10	20V-0.5
21	1	D11	5V1-0.5
22	15	F1, F2, F3, F4, F5, F6, F7, F8, F17, F18, F19, F20, F21, F22, F23	DSS306
23	1	F16	BL02
24	1	JP1	MASCON20
25	1	JP2	JUMPER3
26	1	J1	CON26A
27	1	J2	CON20AP
28	1	J3	FLAT 40P
29	1	K1	ZFH-12V
30	4	PD1, PD2, PD3, PD4	LUNENO
31	2	RP1, RP2	4K7
32	12	R1, R3, R4, R25, R33, R37, R41, R45, R49, R53, R57, R60	33K
33	1	R2	10K-SMD
34	3	R6, R8, R22	10K
35	1	R9	39K
36	7	R10, R11, R13, R14, R15, R16, R46	5K6
37	10	R18, R31, R35, R39, R42, R43, R47, R51, R54, R55	470R
38	2	R19, R20	R
39	1	R23	1M
40	2	R26, R27	100R
41	2	R28, R29	22R
42	1	R30	3K3
43	2	R34, R50	100K
44	1	R38	330R
45	1	R58	2K2
46	1	R59	RXE040
47	1	R61	237R
48	1	R62	1K1
49	1	TP1	TP
50	10	TR1, TR2, TR3, TR4, TR5, TR6, TR7, TR8, TR9, TR10	87X-20K
51	1	U1	LM7805
52	1	U2	TC7660
53	3	U3, U5, U6	TS914
54	1	U4	ICL232
55	1	U7	LM317L

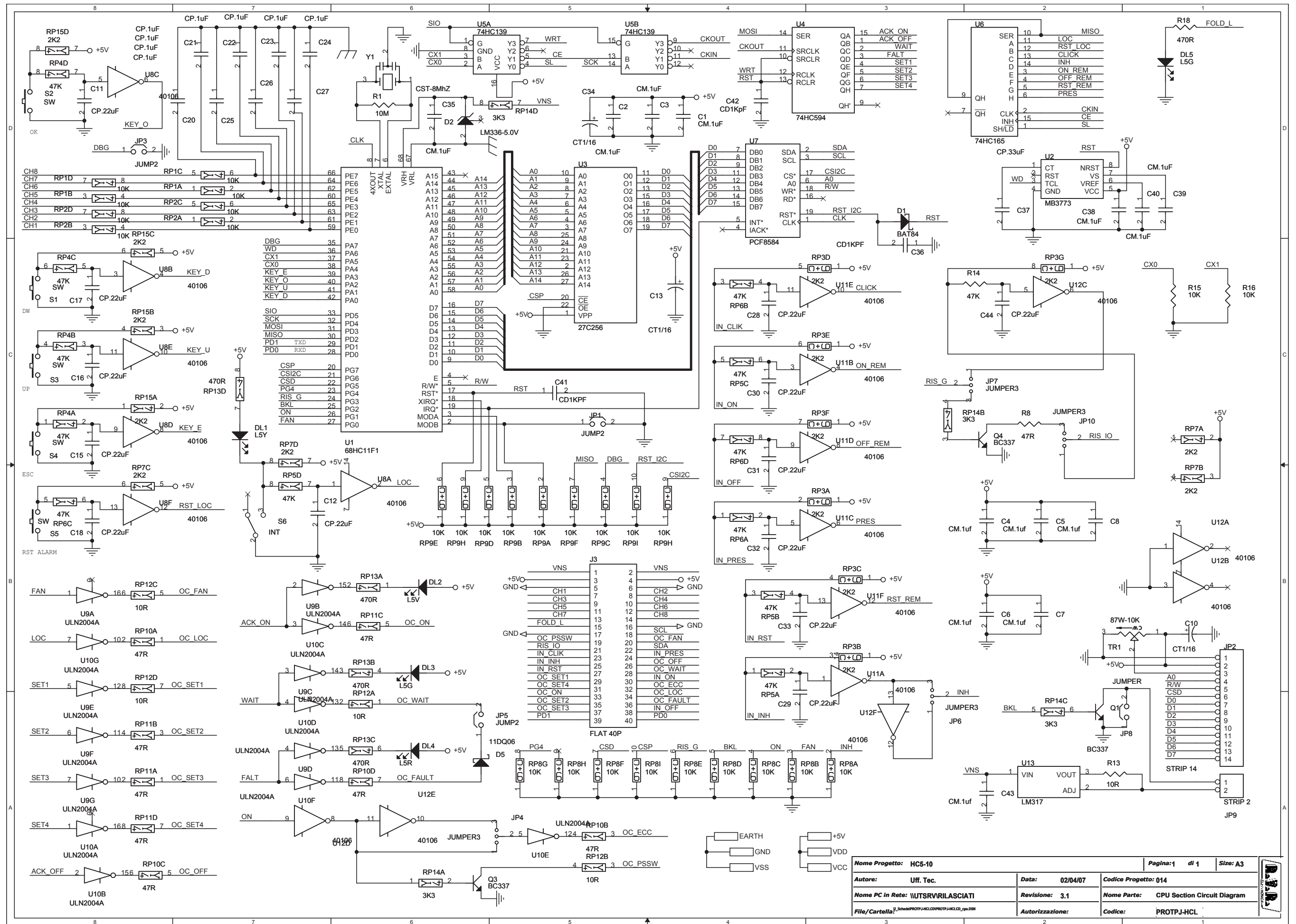

PIANO DI MONTAGGIO LATO SALDATURE

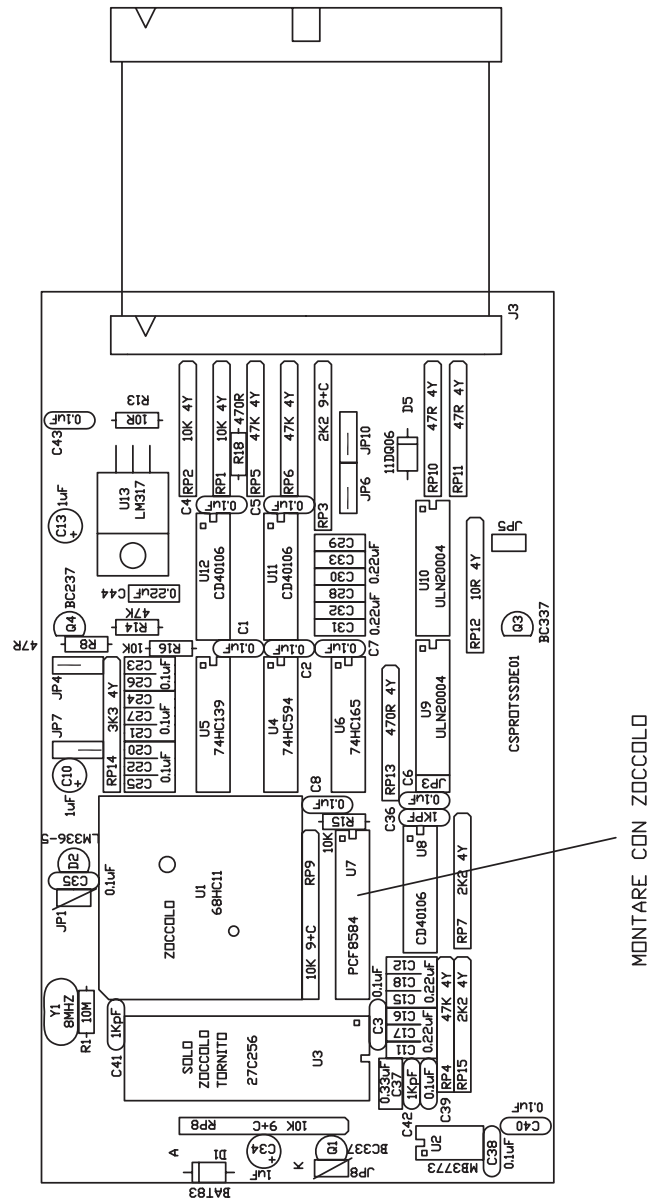

Revised: Thursday, January 08, 2009
Revision:

Item	Quantity	Reference	Part
1	13	C1, C2, C3, C4, C5, C6, C7, C8, C35, C38, C39, C40, C43	CM.1uf
2	3	C10, C13, C34	CT1/16
3	13	C11, C12, C15, C16, C17, C18, C28, C29, C30, C31, C32, C33, C44	CP.22uF
4	8	C20, C21, C22, C23, C24, C25, C26, C27	CP.1uF
5	3	C36, C41, C42	CD1KpF
6	1	C37	CP.33uF
7	1	DL1	L5Y
8	1	DL2	L5V
9	2	DL3, DL5	L5G
10	1	DL4	L5R
11	1	D1	BAT84
12	1	D2	LM336-5.0V
13	1	D5	11DQ06
14	3	JP1, JP3, JP5	JUMP2
15	1	JP2	STRIP 14
16	4	JP4, JP6, JP7, JP10	JUMPER3
17	1	JP8	JUMPER
18	1	JP9	STRIP 2
19	1	J3	FLAT 40P
20	3	Q1, Q3, Q4	BC337
21	6	RP1, RP2, RP8, RP9, R15, R16	10K
22	3	RP3, RP7, RP15	2K2
23	4	RP4, RP5, RP6, R14	47K
24	3	R8, RP10, RP11	47R
25	2	RP12, R13	10R
26	2	RP13, R18	470R
27	1	RP14	3K3
28	1	R1	10M
29	5	S1, S2, S3, S4, S5	SW
30	1	S6	INT
31	1	TR1	87W-10K
32	1	U1	68HC11F1
33	1	U2	MB3773
34	1	U3	27C256
35	1	U4	74HC594
36	1	U5	74HC139
37	1	U6	74HC165
38	1	U7	PCF8584
39	3	U8, U11, U12	40106
40	2	U9, U10	ULN2004A
41	1	U13	LM317
42	1	Y1	CST-8MHz

R.V.R. ELETTRONICA	NOME PROGETTO: HC5-10	NOME PARTE: LCD Alarms Card Layout
	AUTORE: GP - Rev.: J. Berti	DATA: 30/10/2008 REVISIONE: 1.1 SCALA: 1:1 SIZE: A4 PAGINA: 1 DI 1
ARCHIVIAZIONE ELETTRONICA: "CARTELLA PROGETTI" SU "UT_SRV"	CODICE PROGETTO: 014	CODICE DISEGNO: PROTPJ-HCLCD
MATERIALE: FR4-74 1.6mm Cu 35um	TRATTAMENTO: STANDARD COSTRUTTORE	PROFILO: Positivo STATO: ESECUTIVO

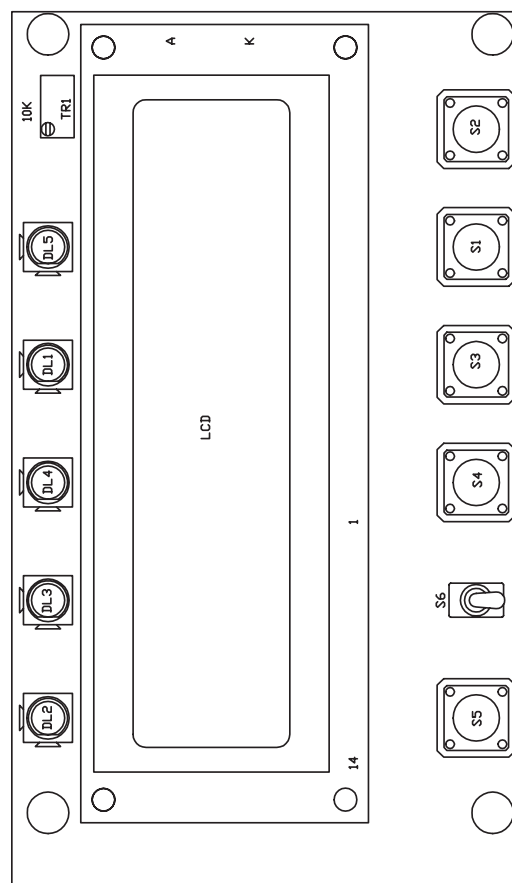

	NOME PROGETTO: HC5-10	NOME PARTE: CPU Display Section Component Layout			
	AUTORE: GP - Rev.: J. Berti	DATA: 11/02/2004	REVISIONE: 2.0	SCALA: 1:1	SIZE: A4
ARCHIVIAZIONE ELETTRONICA: "CARTELLA PROGETTI" SU "UT_SRV"		CODICE PROGETTO: 014	CODICE DISEGNO: PROTPJ-HCLCD		
MATERIALE: FR4-74 1.6mm Cu 35um	TRATTAMENTO: STANDARD COSTRUTTORE	PROFILO: Positivo	STATO: ESECUTIVO		

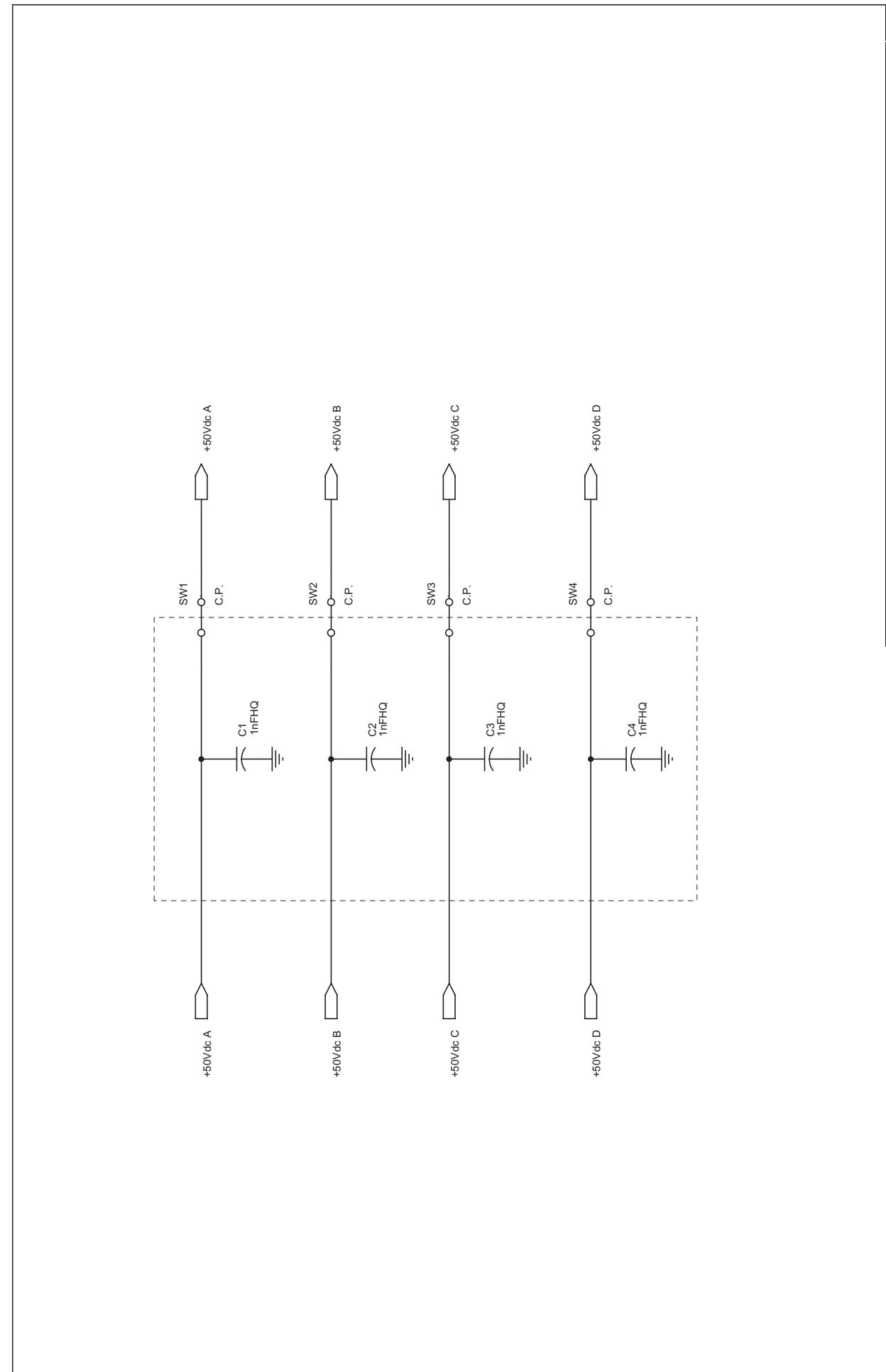
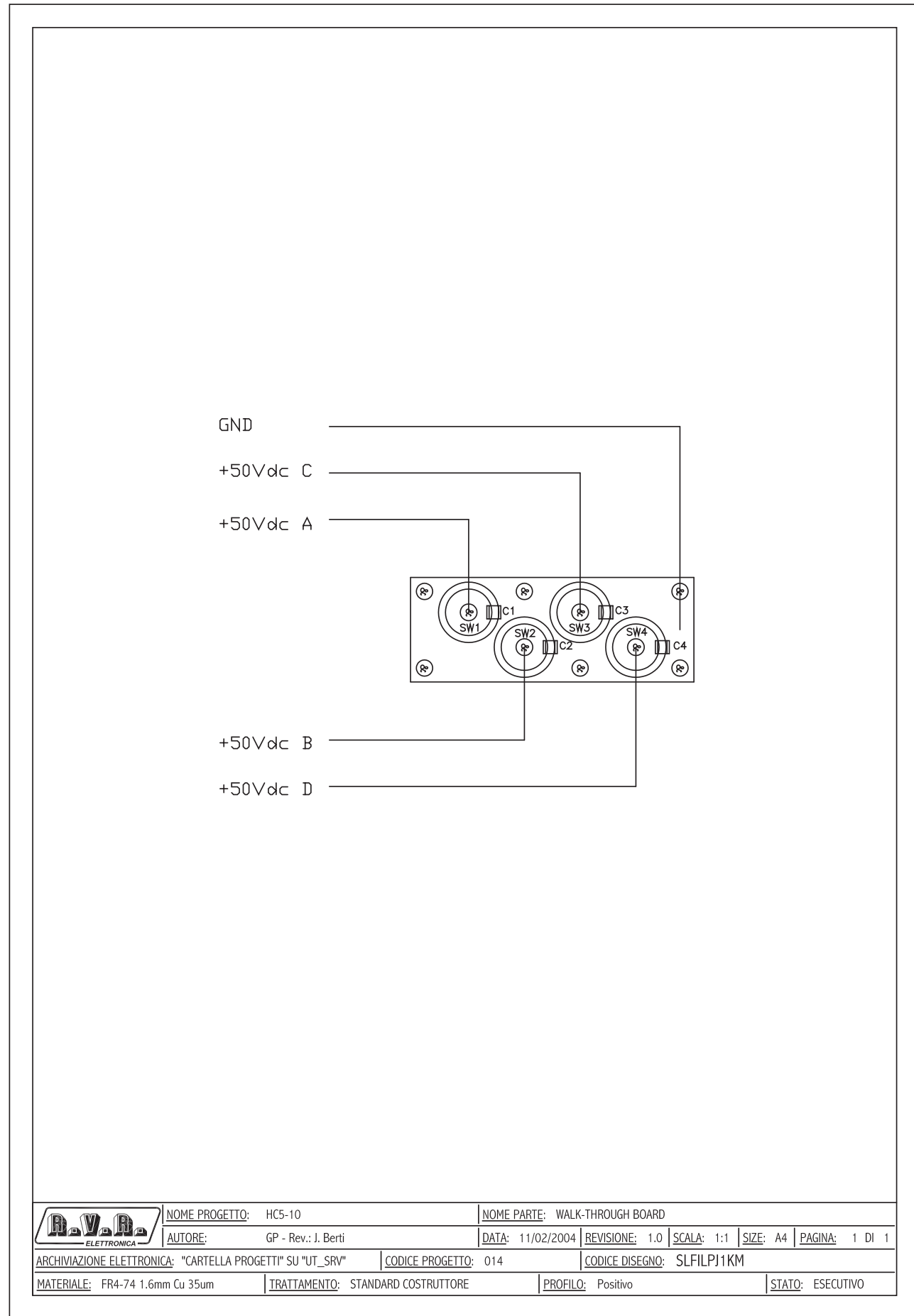

Nome Progetto: HC5-10	Pagina: 1 di 1	Size: A4
Autore: Ufficio Tecnico	Data: 29/10/03	Codice Progetto: 014
Nome PC in Rete: \IUT_SRV\PROGETTI	Revisione: 2.0	Nome Parte: SCHEDA PASSA PARETE
File/Carrella\HC5-10\SLFILPJ1KM\CSFILPJ1KM.dwg	Autore: GP	Codice: SLFILPJ1KM

ARCHIVIAZIONE ELETTRONICA: "CARTELLA PROGETTI" SU "UT_SRV"	NOME PROGETTO: HC5-10	NOME PARTE: WALK-THROUGH BOARD
MATERIALE: FR4-74 1.6mm Cu 35um	AUTORE: GP - Rev.: I. Berti	DATA: 11/02/2004
TRATTAMENTO: STANDARD COSTRUTTORE	REVISIONE: 1.0	SCALA: 1:1
PROFILO: Positivo	SIZE: A4	PAGINA: 1 DI 1
STATO: ESECUTIVO	CODICE PROGETTO: 014	CODICE DISEGNO: SLFILPJ1KM

SCHEDA PASSA PARETE Revised: Oct 30, 2003
SLFILPJ1KM Revision: 2.0
HC5-10

Item	Quantity	Reference	Part
1	4	C1, C2, C3, C4	1nFHQ
2	4	SW1, SW2, SW3, SW4	C.P.

W1 LINK CONFIGURATION

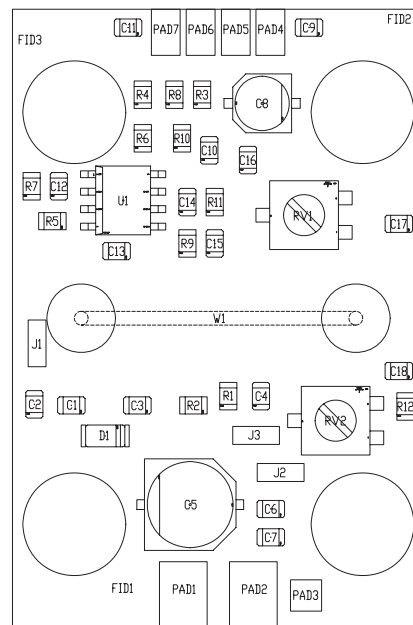
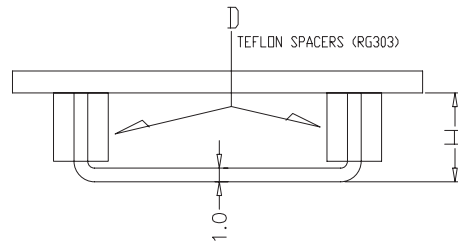

- J1: 88-108 MHz LINEARITY
- J2: LIGHT STABILIZER DELAY SYSTEM
- J3: HEAVY STABILIZER DELAY SYSTEM
- PAD1: GND (PASSIVE RF MEASUREMENT)
- PAD2: SIGNAL (PASSIVE RF MEASUREMENT)
- PAD3: SIGNAL GND (PASSIVE RF MEASUREMENT)
- PAD4: +12VCC (AMPLIF. RF MEASUREMENT)
- PAD5: SIGNAL GND (AMPLIF. RF MEASUREMENT)
- PAD6: GND (AMPLIF. RF MEASUREMENT)
- PAD7: SIGNAL (AMPLIF. RF MEASUREMENT)
- RV1: DIRECTIVITY ADJUSTMENT
- RV2: NORMALIZATION LEVEL

CONFIGURATIONS DETAIL

CARD CODE	H link W1 (mm)	D spacers W1	Jumper J1	Jumper J2	Jumper J3
SL042MT1001					
SL042MT1101	5.3		X		
SL042MT1201	4		X		
SL042MT1301	7.6		X		
SL042MT1401	8.5	X	X		X
SL042MT1501	4.5		X		

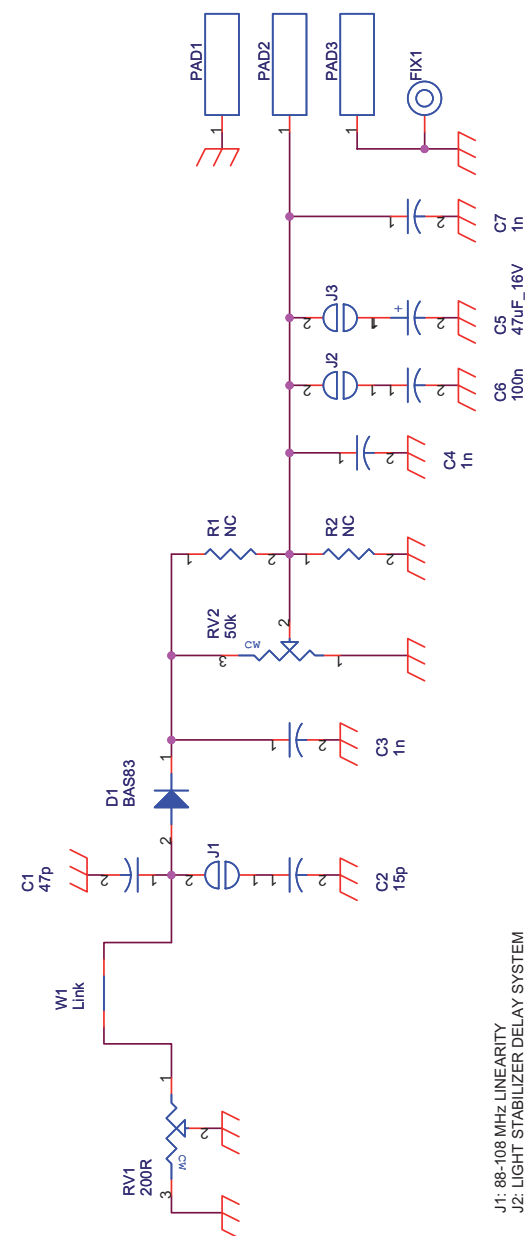
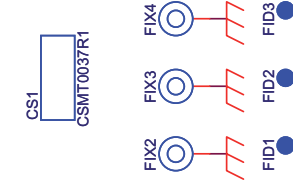

- J1: 88-108 MHz LINEARITY
- J2: LIGHT STABILIZER DELAY SYSTEM
- J3: HEAVY STABILIZER DELAY SYSTEM
- PAD1: GND (PASSIVE RF MEASUREMENT)
- PAD2: SIGNAL (PASSIVE RF MEASUREMENT)
- PAD3: SIGNAL GND (PASSIVE RF MEASUREMENT)
- PAD4: +12VCC (AMPLIF. RF MEASUREMENT)
- PAD5: SIGNAL GND (AMPLIF. RF MEASUREMENT)
- PAD6: GND (AMPLIF. RF MEASUREMENT)
- PAD7: SIGNAL (AMPLIF. RF MEASUREMENT)
- RV1: DIRECTIVITY ADJUSTMENT
- RV2: NORMALIZATION LEVEL

NOTE
TO SEE THE CARD VARIANTS AND THE "W1"
LINK CONFIGURATIONS, CONSULT THE LAYOUT
(SL042MT1001-DWG)

	PROJECT NAME:	POWER METER	PART No.:	POWER METER
	DESIGNER:	M. UCELLI	DATE:	12/07/2006
FILE LOCATION:	\\Utsrv\Rilasciati\2_Schede\SL042MT1001		REVISION:	1.0
MATERIAL:	<>	TREATMENT:	<>	PROFILE:
			SCALE:	2:1
			SIZE:	A4
			PAGE:	1 OF 1
		PROJECT CODE:	042	CODE:
				SL042MT1001
			STATE:	EXECUTIVE

Project Name:	Generic RF PWR Measurement	Page:	1 of 1	Size:	A4
Designer:	Mauro Ucelli	Project Code:	042	Date:	Thursday, April 11, 2008
File Location:	\\UTSRV\RILASCIATI	Revision:	1.1	Description:	RF Power measure board
Folder/File:	/	Approval:		Part No.:	SL042MT1001

RF Power measure board
SL042MT1001
Revision: 1.1
Generic RF PWR Measurement
042
Mauro Ucelli
17/04/2008

Item	Quantity	Reference	Part	Description	Code1
1	1	CS1	CSMT0037R1	Printed Circuit Board	CSMT0037R1
2	1	C1	47p	SMD 0805 COG Capacitor	CCC085470JCC
3	1	C2	15p	SMD 0805 COG Capacitor	CCC085150JCC
4	3	C3,C4,C7	1n	SMD 0805 Capacitor	CCC085102JNC
5	1	C5	47uF_16V	Elect. SMD d. 6.3mm Cap.	CES476C160
6	1	C6	100n	SMD 0805 Capacitor	CCC085104KXC
7	1	D1	BAS83	MINIMELF SMD Diode	DHCBAS83
8	3	FID1,FID2,FID3	FID		
9	4	FIX1,FIX2,FIX3,FIX4	FIX35	Fixing Hole 3.5mm	
10	3	J1,J2,J3	JSMD	SMD Pad to solder	
11	3	PAD1,PAD2,PAD3	PAD		
12	1	RV1	200R	Trimmer SMD	RVT4X4H0200V
13	1	RV2	50k	Trimmer SMD	RVT4X4K0050V
14	2	R1,R2	NC	SMD 0805 Res.	
15	1	W1	Link	Wire to solder	See the Layout

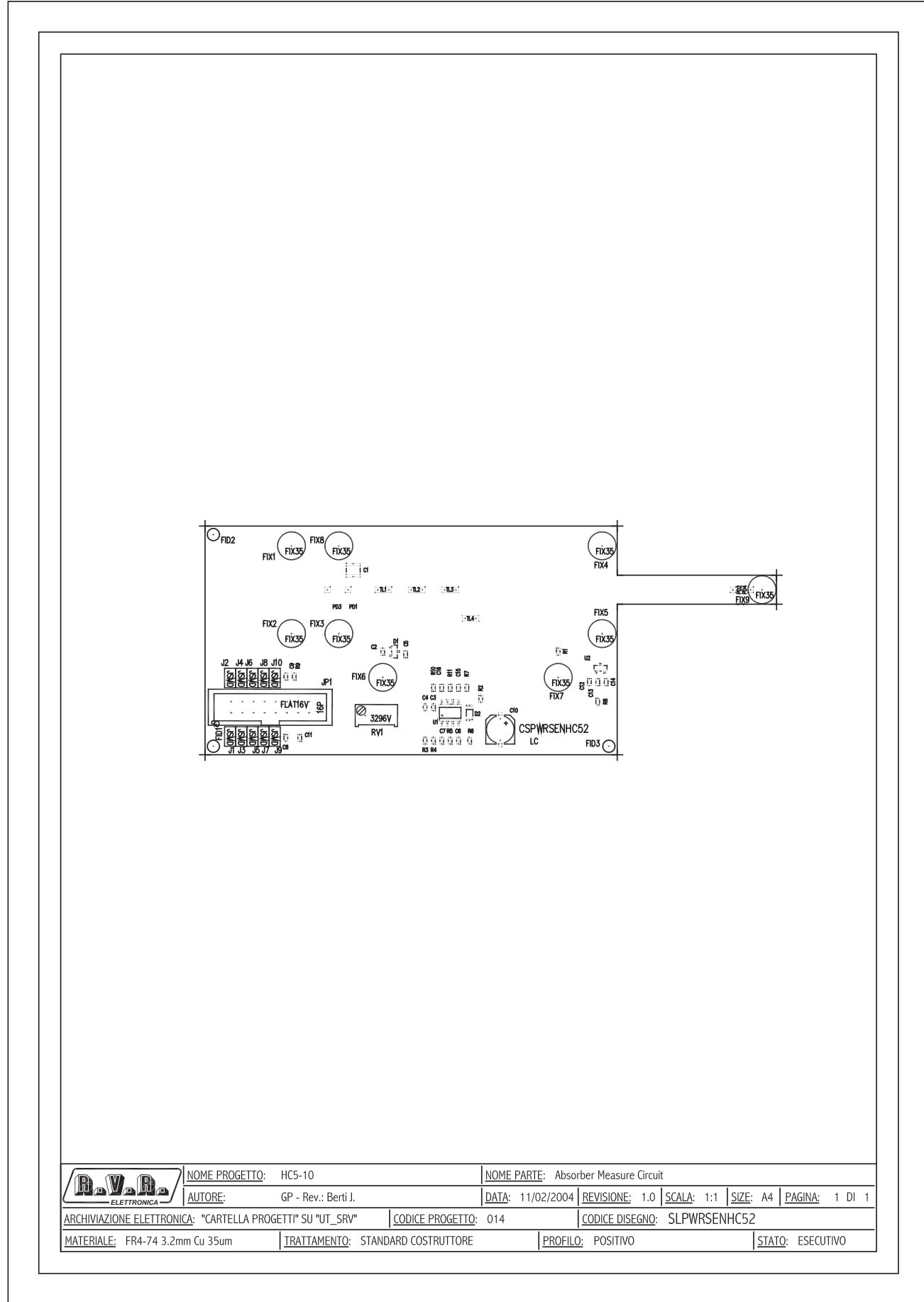

R.V.R. ELETTRONICA	NOME PROGETTO: HC5-10	NOME PARTE: Absorber Measure Circuit
AUTORE: GP - Rev.: Berti J.	DATA: 11/02/2004	REVISIONE: 1.0
ARCHIVIAZIONE ELETTRONICA: "CARTELLA PROGETTI" SU "UT_SRV"	CODICE PROGETTO: 014	CODICE DISEGNO: SLPWRSEHC52
MATERIALE: FR4-74 3.2mm Cu 35um	TRATTAMENTO: STANDARD COSTRUTTORE	PROFILO: POSITIVO
		STATO: ESECUTIVO

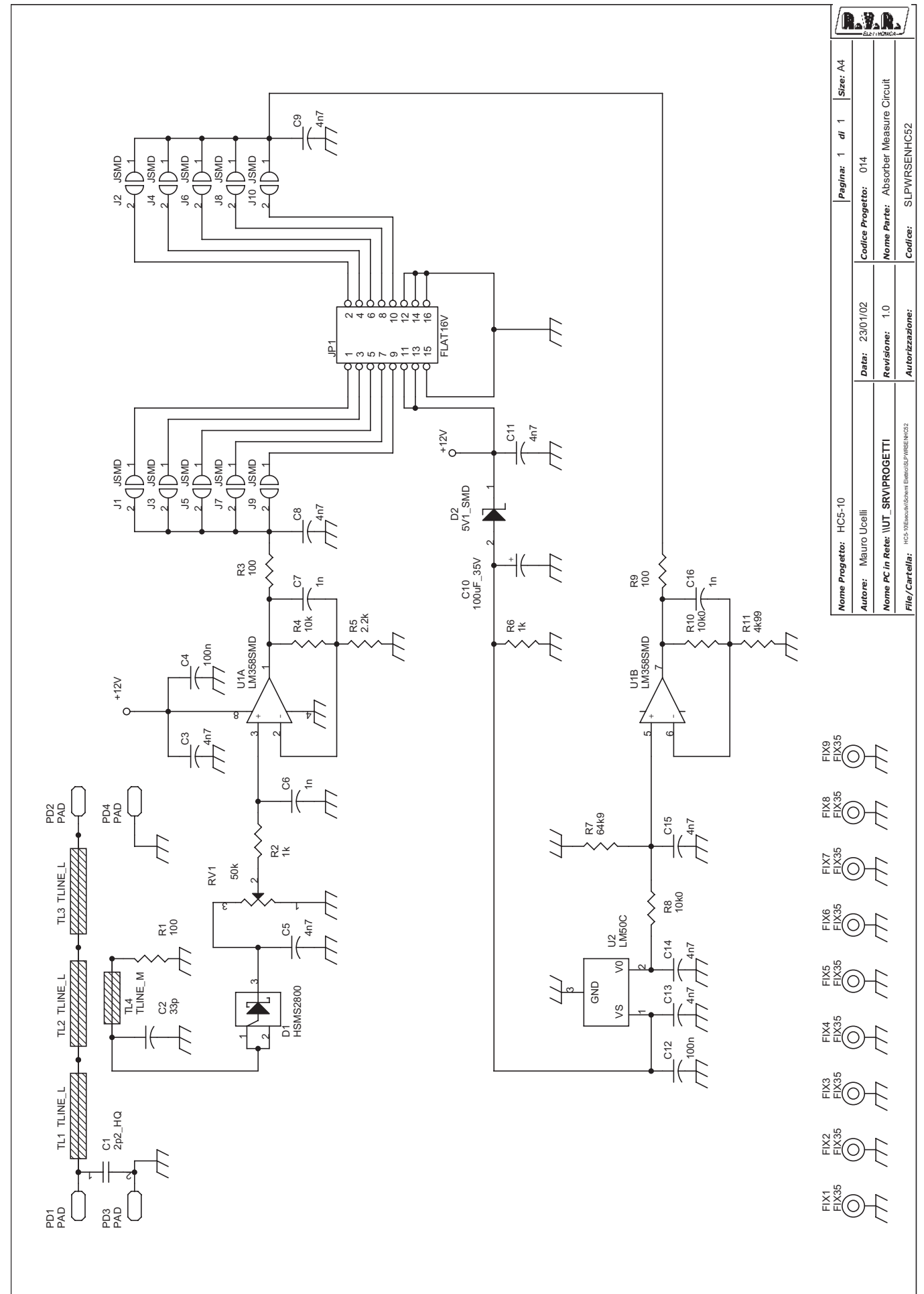

R.V.R. ELETTRONICA	NOME PROGETTO: HC5-10	Pagina: 1 di 1	Size: A4
AUTORE: Mauro Ucelli	DATA: 23/01/02	Codice Progetto: 014	
NOME PC In Rete: \UT_SRV\PROGETTI	REVISIONE: 1.0	NOME PARTE: Absorber Measure Circuit	
FILE/CARTELLA: HC5-10\Archivio\Berti\SLPWRSEHC52	AUTORIZZAZIONE:	CODICE:	SLPWRSEHC52

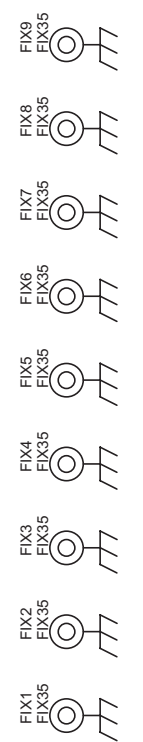

Absorber Measure Circuit Revised: Thursday, February 26, 2004

SLPWRSEHC52 Revision: 1.0

HC5-10

14

Mauro Ucelli

Item	Quantity	Reference
1	1	C1
2	1	C2
3	8	C3, C5, C8, C9, C11, C13, C14, C15
4	2	C12, C4
5	3	C6, C7, C16
6	1	C10
7	1	D1
8	1	D2
9	9	FIX1, FIX2, FIX3, FIX4, FIX5, FIX6, FIX7, FIX8, FIX9
10	1	JP1
11	10	J1, J2, J3, J4, J5, J6, J7, J8, J9, J10
12	4	PD1, PD2, PD3, PD4
13	1	RV1
14	3	R1, R3, R9
15	2	R6, R2
16	1	R4
17	1	R5
18	1	R7
19	2	R8, R10
20	1	R11
21	3	TL1, TL2, TL3
22	1	TL4
23	1	U1
24	1	U2

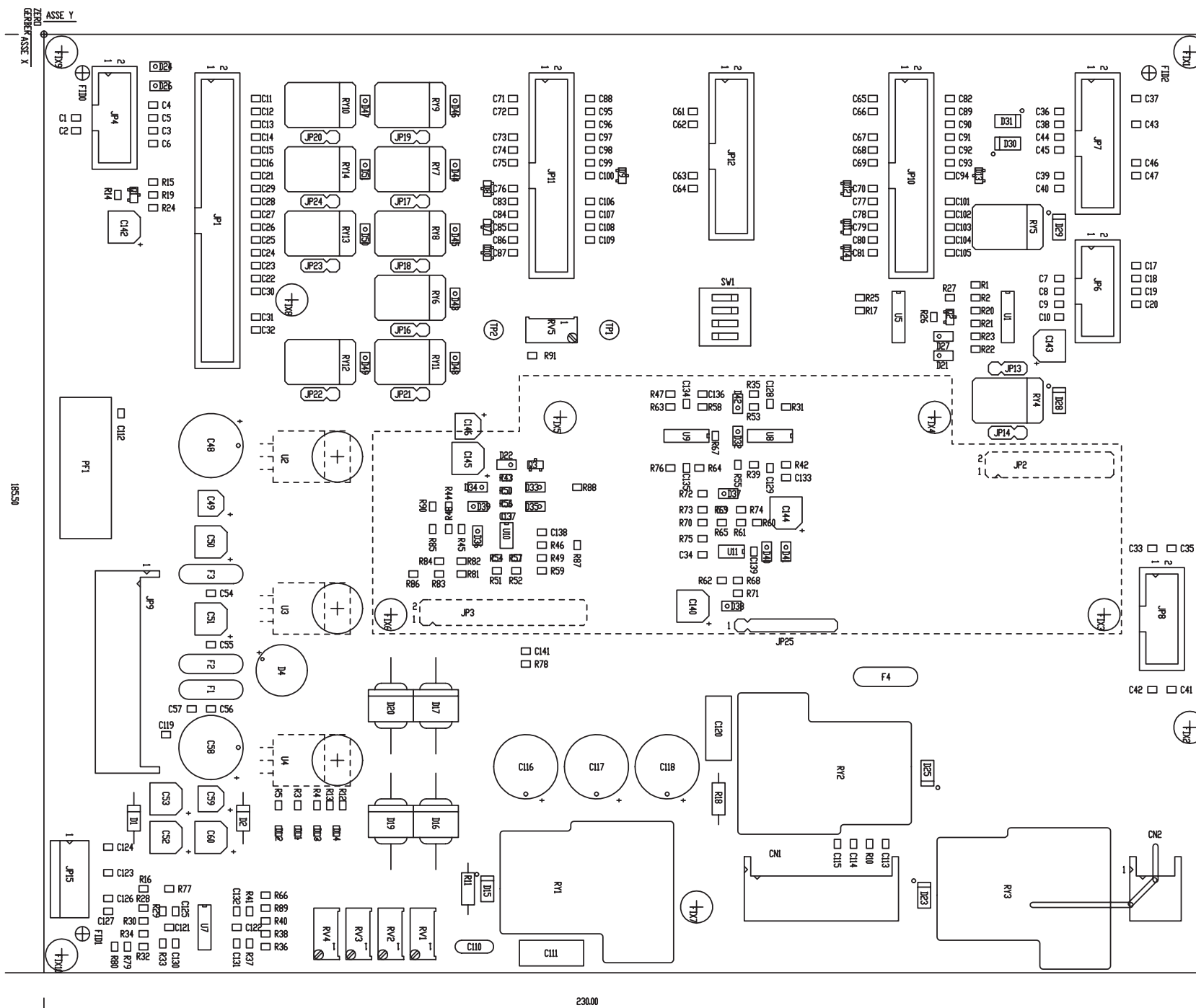

	NOME PROGETTO: HC5-10	NOME PARTE: Interfaccia di controllo
	AUTORE: S. Poluzzi - Rev.: Berti J.	DATA: 11/02/2004 REVISIONE: 1.0 SCALA: 1:1 SIZE: A3 PAGINA: 1 DI 1
ARCHIVIAZIONE ELETTRONICA: "CARTELLA PROGETTI" SU "UT_SRV"	CODICE PROGETTO: 014	CODICE DISEGNO: SLINHC5-10-2
MATERIALE: FR4-74 1.6mm Cu 35um	TRATTAMENTO: STANDARD COSTRUTTORE	PROFILO: POSITIVO STATO: ESECUTIVO

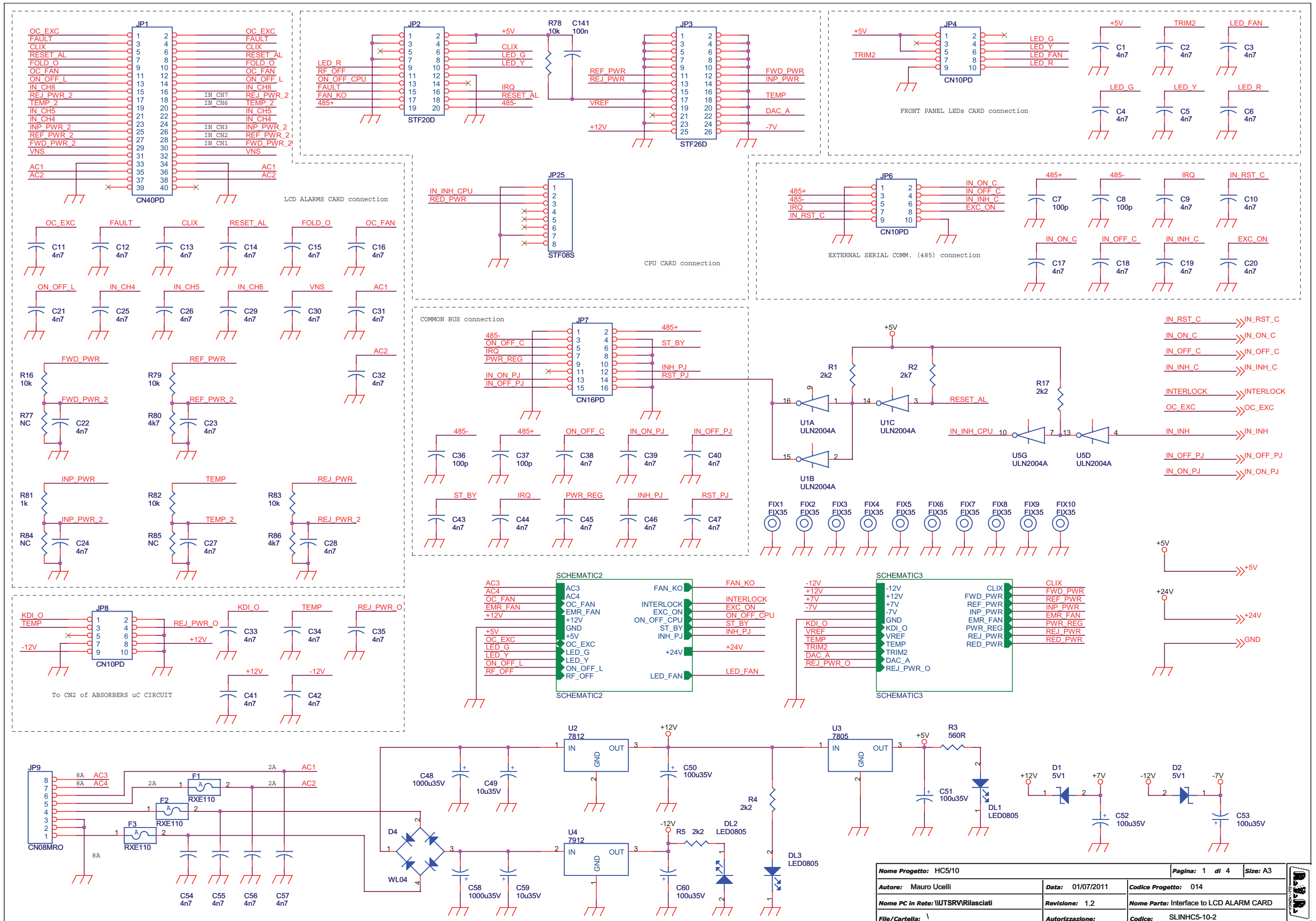

Nome Progetto: HC5/10		Pagina: 1 di 4		Size: A3
Autore: Mauro Ucelli		Data: 01/07/2011	Codice Progetto: 014	
Nome PC in Rete: WUTSRV/Rilasciati		Revisione: 1.2	Nome Parte: Interface to LCD ALARM CARD	
File/Cartella: \		Autorizzazione:	Codice: SLINHC5-10-2	

SLINH5-10-2

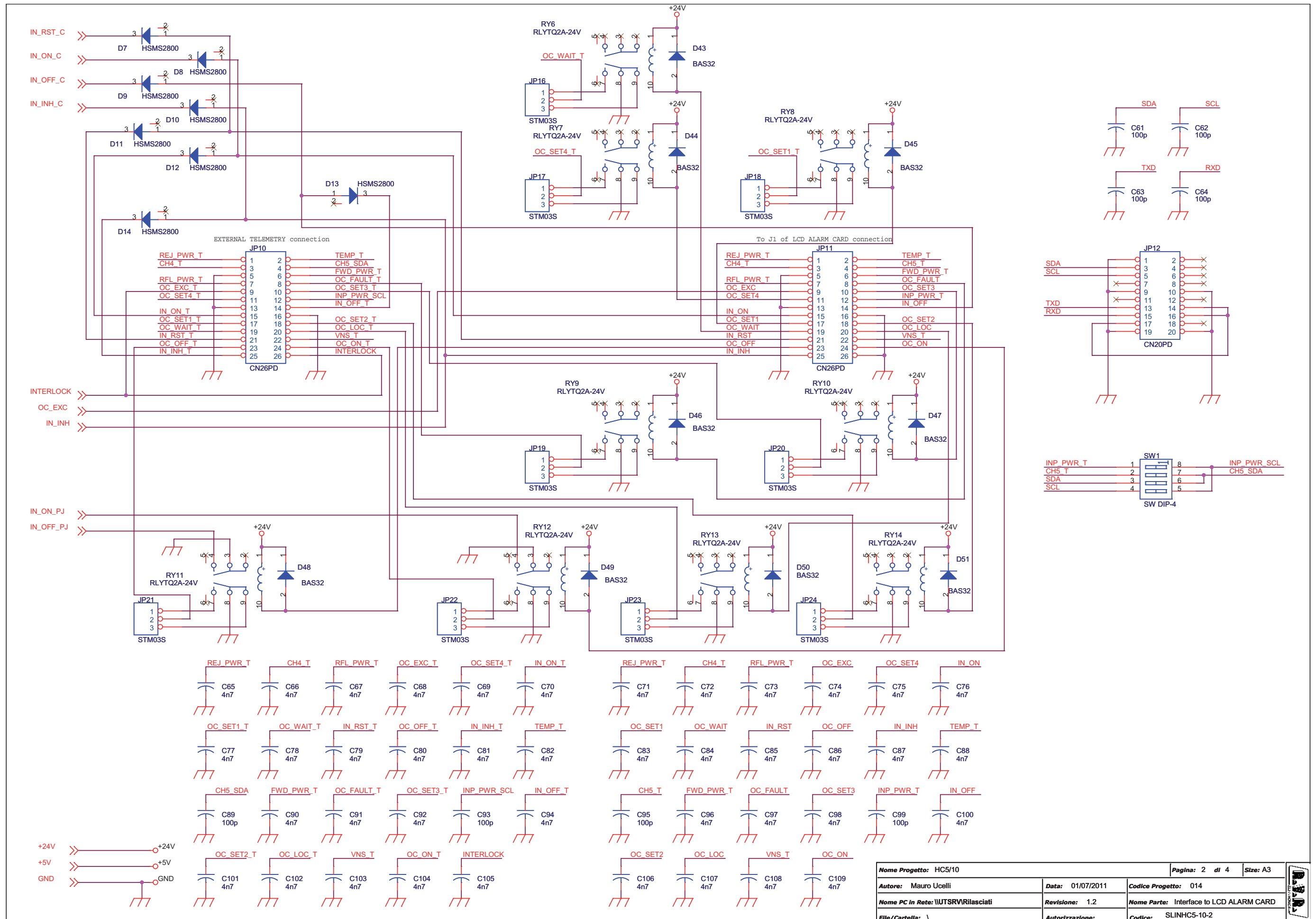

Nome Progetto: HC5/10		Pagina: 2 di 4		Size: A3
Autore: Mauro Ucelli	Data: 01/07/2011	Codice Progetto: 014		
Nome PC in Rete: \UTSRV\Rilasciati	Revisione: 1.2	Nome Parte: Interface to LCD ALARM CARD		
File/Cartella: \	Autorizzazione:	Codice: SLINH5-10-2		

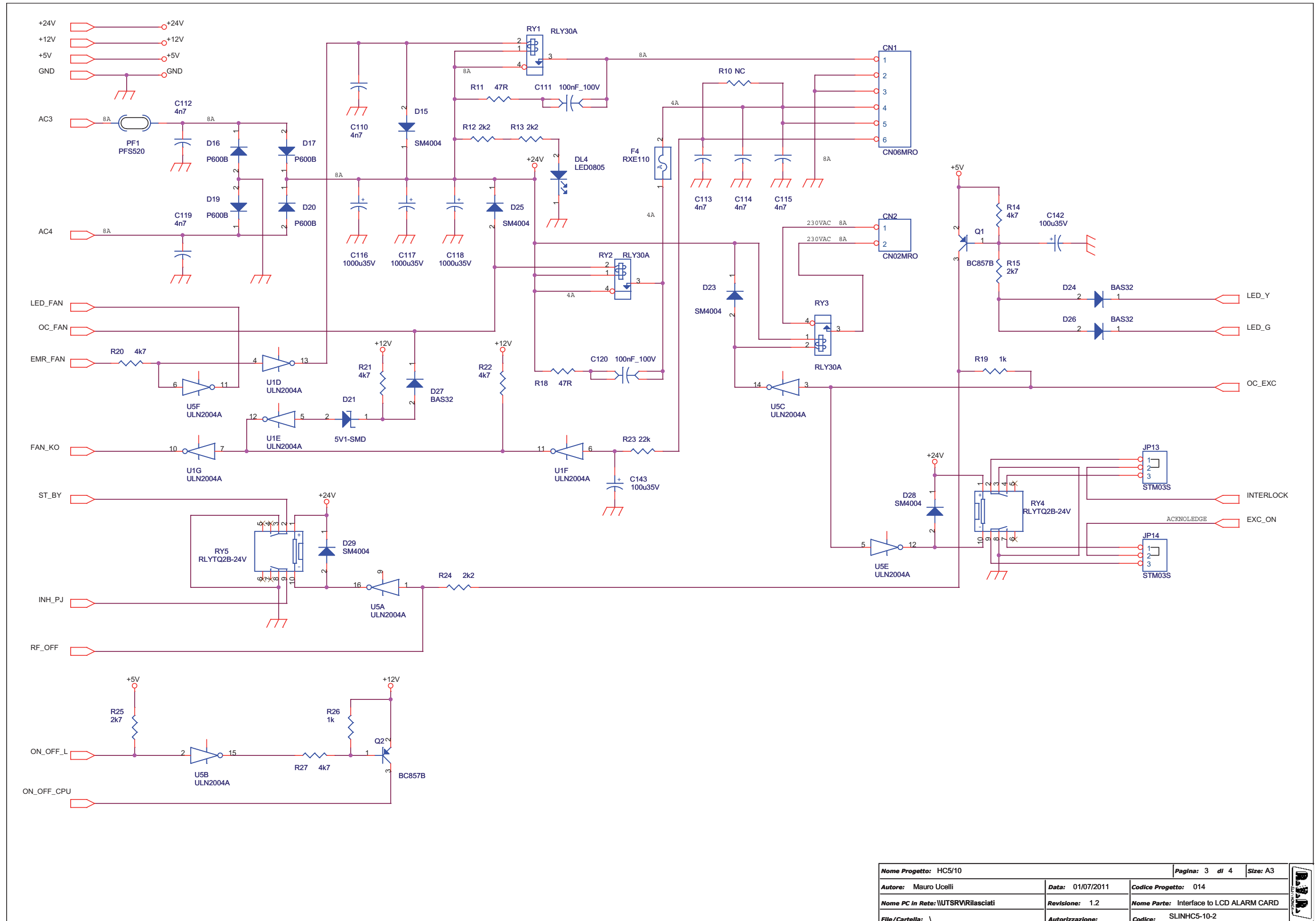

Nome Progetto: HC5/10		Pagina: 3 di 4	Size: A3
Autore: Mauro Ucelli	Data: 01/07/2011	Codice Progetto: 014	
Nome PC in Rete: \UTSRV\Rilasciati	Revisione: 1.2	Nome Parte: Interface to LCD ALARM CARD	
File/Cartella: \	Autorizzazione:	Codice: SLINHC5-10-2	

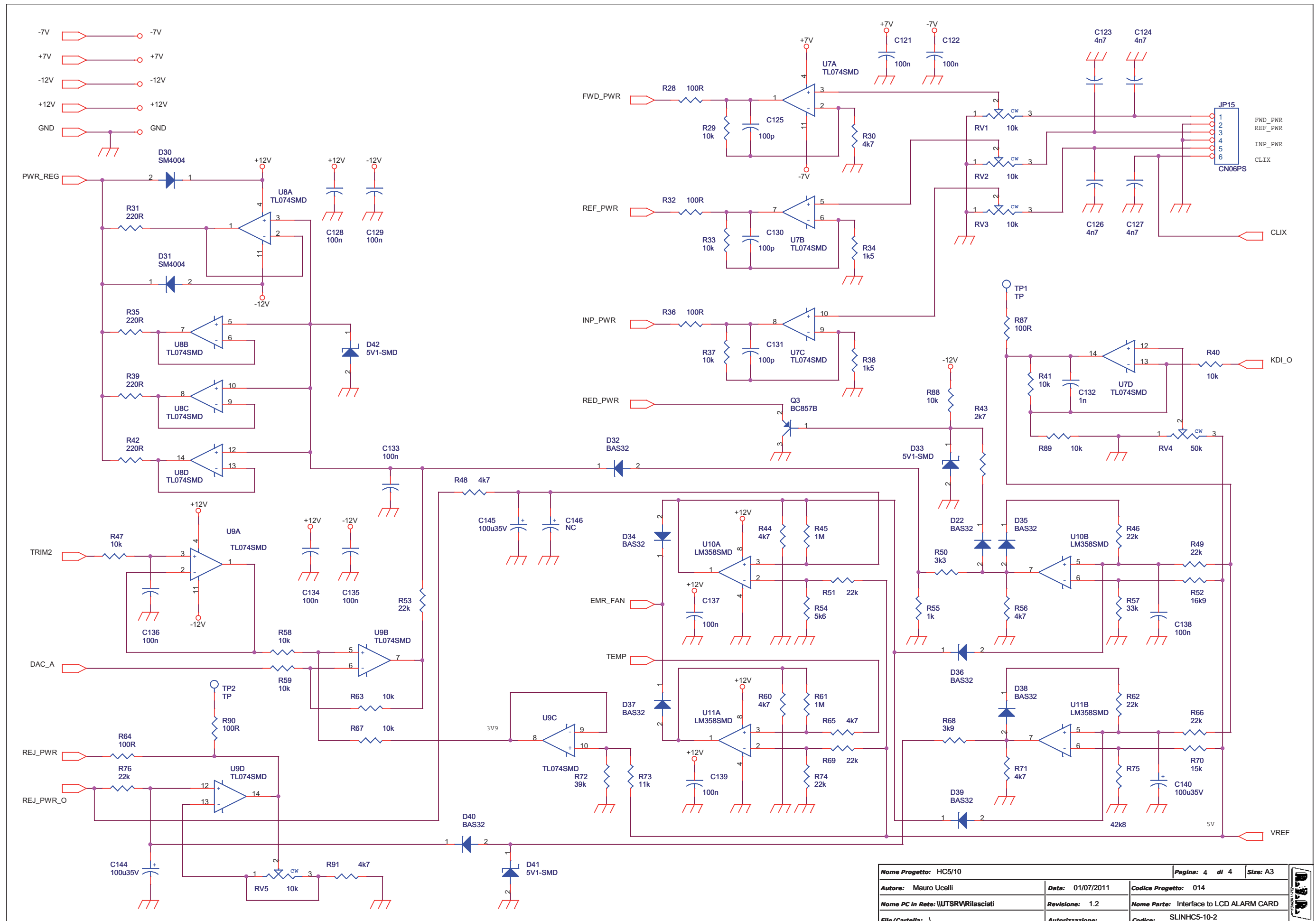

Nome Progetto: HC5/10		Pagina: 4 di 4		Size: A3
Autore: Mauro Ucelli	Data: 01/07/2011	Codice Progetto: 014		
Nome PC in Rete: \UTSRV\Rilasciati		Revisione: 1.2	Nome Parte: Interface to LCD ALARM CARD	
File/Cartella: \	Autorizzazione:	Codice: SLINHC5-10-2		

SLINHC5-10-2

Interface to LCD ALARM CARD
 SLINHC5-10-2
 HC5/10 -014-
 Rev.1.1 06/07/2010

Item	Q.ty	Reference	Part	Description
1	1	CN1	CN06MRO	Cnt KB 90° p. 5mm 6 pin
2	1	CN2	CN02MRO	Cnt KB 90° p. 5mm 6 pin
3	97	C1, C2, C3, C4, C5, C6, C9, C10, C11, C12, C13, C14, C15, C16, C17, C18, C19, C20, C21, C22, C23, C24, C25, C26, C27, C28, C29, C30, C31, C32, C33, C34, C35, C38, C39, C40, C41, C42, C43, C44, C45, C46, C47, C54, C55, C56, C57, C65, C66, C67, C68, C69, C70, C71, C72, C73, C74, C75, C76, C77, C78, C79, C80, C81, C82, C83, C84, C85, C86, C87, C88, C90, C91, C92, C94, C96, C97, C98, C100, C101, C102, C103, C104, C105, C106, C107, C108, C109, C112, C113, C114, C115, C119, C123, C124, C126, C127	4n7	Cond. SMD 0805
4	15	C7, C8, C36, C37, C61, C62, C63, C64, C89, C93, C95, C99, C125, C130, C131	100p	Cond. SMD 0805
5	5	C48, C58, C116, C117, C118	1000u35V	Cond. Elettr. Dia 13 P5.08
6	2	C59, C49	10u35V	Cond. Elettr. SMD d. 5mm
7	10	C50, C51, C52, C53, C60, C140, C142, C143, C144, C145	100u35V	Cond. Elettr. SMD d. 6.3mm
8	1	C110	4n7	Cond. ceramico multistr. p 5mm
9	2	C111, C120	100nF_100V	Cond. Poli. p 5/7.5/10mm
10	12	C121, C122, C128, C129, C133, C134, C135, C136, C137, C138, C139, C141	100n	Cond. SMD 0805
11	1	C132	1n	Cond. SMD 0805
12	1	C146	NC	Cond. Elettr. SMD d. 5mm
13	4	DL1, DL2, DL3, DL4	LED0805	LED SMD 0805
14	2	D2, D1	5V1	1W Zener Diode
15	1	D4	WL04	Ponte diodi tondi W
16	8	D7, D8, D9, D10, D11, D12, D13, D14	HSMS2800	Diode SMD SOT23
17	7	D15, D23, D25, D28, D29, D30, D31	SM4004	MELF SMD Diode
18	4	D16, D17, D19, D20	P600B	Diode plastico P600
19	4	D21, D33, D41, D42	5V1-SMD	MINIMELF SMD Zener Diode
20	21	D22, D24, D26, D27, D32, D34, D35, D36, D37, D38, D39, D40, D43, D44, D45, D46, D47, D48, D49, D50, D51	BAS32	MINIMELF SMD Diode
21	10	FIX1, FIX2, FIX3, FIX4, FIX5, FIX6, FIX7, FIX8, FIX9, FIX10	FIX35	Foro fissaggio 3.5mm
22	4	F1, F2, F3, F4	RXE110	Fusibile autorip. 13mm
23	1	JP1	CN40PD	Connettore 40 poli Flat cs
24	1	JP2	STF20D	Strip femmina 10+10 pin
25	1	JP3	STF26D	Strip femmina 13+13 pin
26	3	JP4, JP6, JP8	CN10PD	Connettore 10 poli Flat cs
27	1	JP25	STF08S	Strip femmina 8 pin
28	1	JP7	CN16PD	Connettore 16 poli Flat cs
29	1	JP9	CN08MRO	Connettore KB 90° p. 5mm 8 pin
30	2	JP10, JP11	CN26PD	Connettore 26 poli Flat cs
31	1	JP12	CN20PD	Connettore 20 poli Flat cs
32	11	JP13, JP14, JP16, JP17, JP18, JP19, JP20, JP21, JP22, JP23, JP24	STM03S	Strip maschio 3 pin

2	1	CN2	CN02MRO	Cnt KB 90° p. 5mm 6 pin
3	97	C1, C2, C3, C4, C5, C6, C9, C10, C11, C12, C13, C14, C15, C16, C17, C18, C19, C20, C21, C22, C23, C24, C25, C26, C27, C28, C29, C30, C31, C32, C33, C34, C35, C38, C39, C40, C41, C42, C43, C44, C45, C46, C47, C54, C55, C56, C57, C65, C66, C67, C68, C69, C70, C71, C72, C73, C74, C75, C76, C77, C78, C79, C80, C81, C82, C83, C84, C85, C86, C87, C88, C90, C91, C92, C94, C96, C97, C98, C100, C101, C102, C103, C104, C105, C106, C107, C108, C109, C112, C113, C114, C115, C119, C123, C124, C126, C127	4n7	Cond. SMD 0805
33	1	JP15	CN06PS	Connettore 6 poli Panduit
34	1	PF1	PFS520	Portafusibile 5x20
35	3	Q1, Q2, Q3	BC857B	Trans. PNP SOT23
36	4	RV1, RV2, RV3, RV5	10k	Trimmer Rg V 3296W
37	1	RV4	50k	Trimmer Rg V 3296W
38	3	RY1, RY2, RY3	RLY30A	Rele' 30A NO
39	2	RY5, RY4	RLYTQ2B-24V	Rele' TQ2
40	9	RY6, RY7, RY8, RY9, RY10, RY11, RY12, RY13, RY14	RLYTQ2A-24V	Rele' TQ2
41	7	R1, R4, R5, R12, R13, R17, R24	2k2	Res. SMD 0805
42	4	R2, R15, R25, R43	2k7	Res. SMD 0805
43	1	R3	560R	Res. SMD 0805
44	4	R10, R77, R84, R85	NC	Res. SMD 0805
45	2	R11, R18	47R	Res. 1/4W
46	15	R14, R20, R21, R22, R27, R30, R44, R48, R56, R60, R65, R71, R80, R86, R91	4k7	Res. SMD 0805
47	17	R16, R29, R33, R37, R40, R41, R47, R58, R59, R63, R67, R78, R79, R82, R83, R88, R89	10k	Res. SMD 0805
48	4	R19, R26, R55, R81	1k	Res. SMD 0805
49	10	R23, R46, R49, R51, R53, R62, R66, R69, R74, R76	22k	Res. SMD 0805
50	6	R28, R32, R36, R64, R87, R90	100R	Res. SMD 0805
51	4	R31, R35, R39, R42	220R	Res. SMD 0805
52	2	R34, R38	1k5	Res. SMD 0805
53	2	R61, R45	1M	Res. SMD 0805
54	2	R50, R68	3k9	Res. SMD 0805
55	1	R52	16k9	Res. SMD 0805
56	1	R54	5k6	Res. SMD 0805
57	1	R57	33k	Res. SMD 0805
58	1	R70	15k	Res. SMD 0805
59	1	R72	39k	Res. SMD 0805
60	1	R73	11k	Res. SMD 0805
61	1	R75	42k8	Res. SMD 0805
62	1	SW1	SW DIP-4	Dip switch 4 vie
63	2	TP2, TP1	TP	Test point
64	2	U5, U1	ULN2004A	Seven Inv. Buffer OC
65	1	U2	7812	Stabilizzatore TO220
66	1	U3	7805	Stabilizzatore TO220
67	1	U4	7912	Stabilizzatore TO220
68	3	U7, U8, U9	TL074SMD	Quad Op. SMD SO14
69	2	U10, U11	LM358SMD	Dual Op. SMD SO8

Nota_1 Valore di R non gestito, sostituito in distinta con pz 1 56K e pz 1 182K in parallelo
 Nota_2 Montare al contrario rispetto alla serigrafia

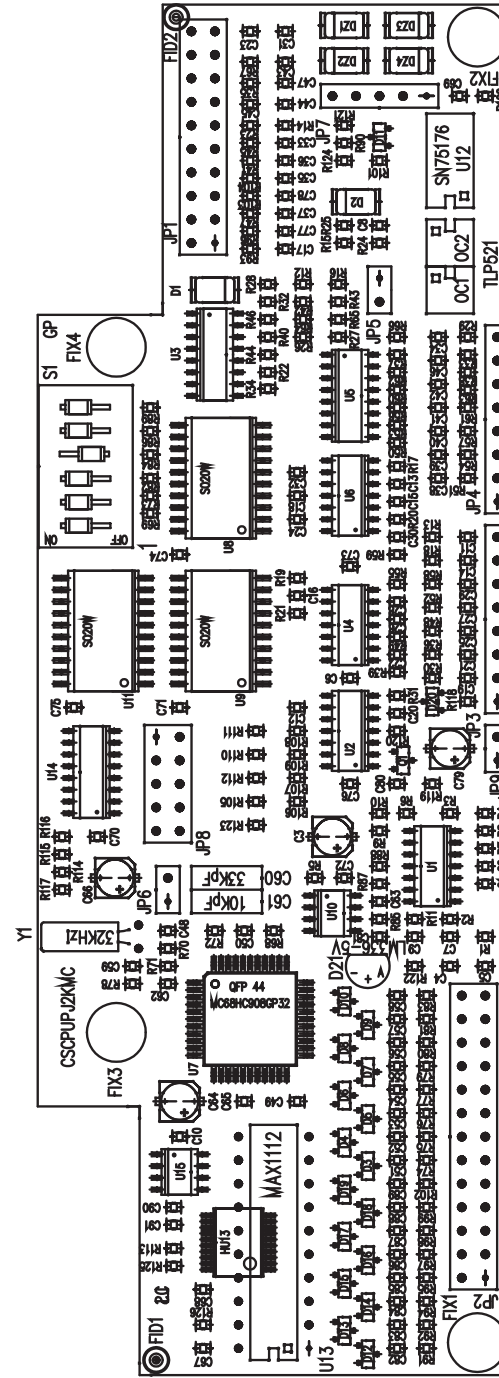

	NOME PROGETTO: HC5/10	NOME PARTE: Scheda CPU
AUTORE: U.T. - Rev.: BERTI J.	DATA: 11/02/2004	REVISIONE: 1.0
ARCHIVIAZIONE ELETTRONICA: "CARTELLA PROGETTI" SU "UT_SRV"	CODICE PROGETTO: 014	CODICE DISEGNO: SLCPUJ2KMC
MATERIALE: /	TRATTAMENTO: /	PROFILO: /
		STATO: ESECUTIVO
		SIZE: A4
		PAGINA: 1 DI 1

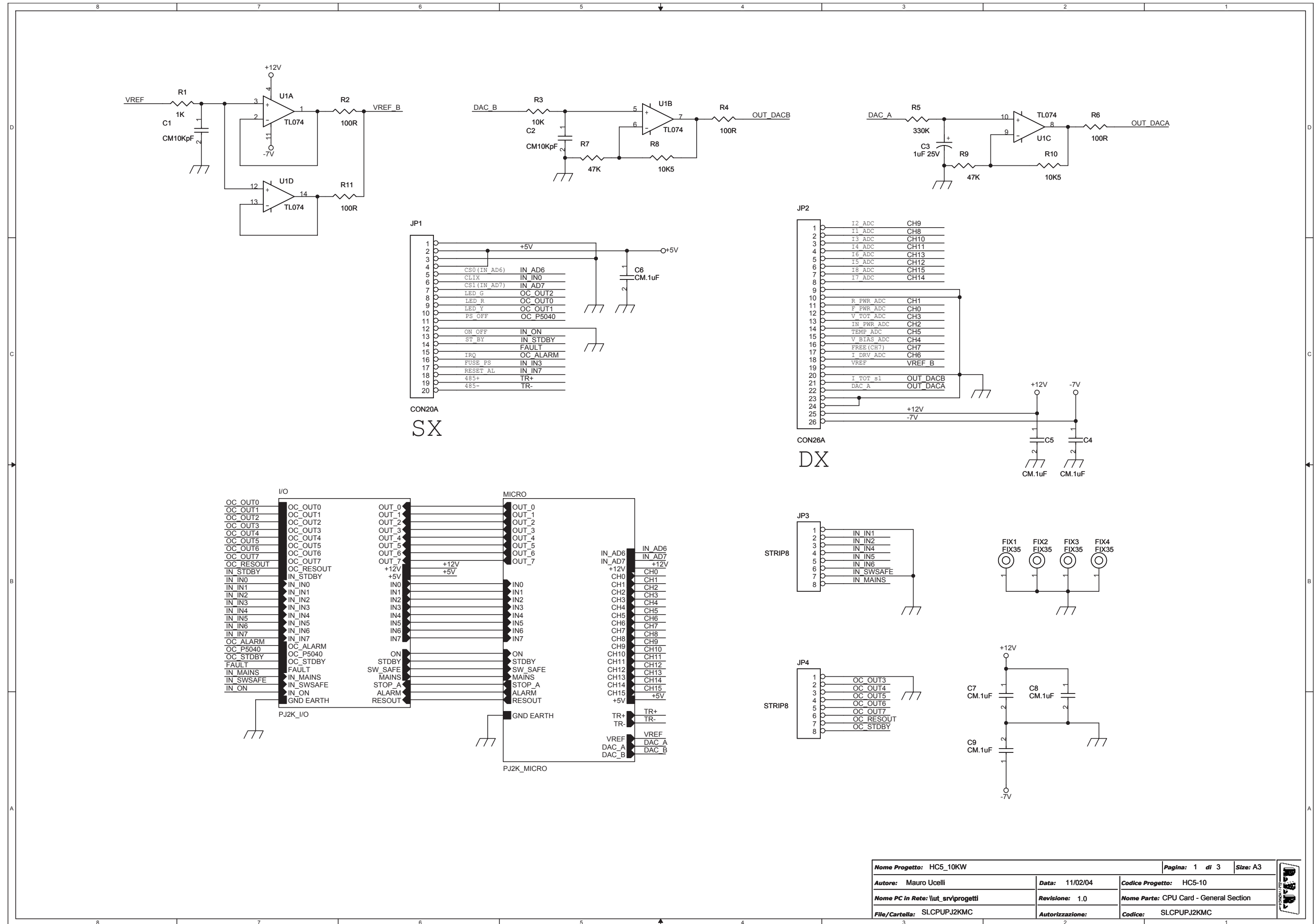

Nome Progetto: HC5_10KW		Pagina: 1 di 3		Size: A3
Autore: Mauro Ucelli		Data: 11/02/04	Codice Progetto: HC5-10	
Nome PC in Rete: \\ut_srv\progetti		Revisione: 1.0	Nome Parte: CPU Card - General Section	
File/Cartella: SLCPUPJ2KMC		Autorizzazione:	Codice: SLCPUPJ2KMC	

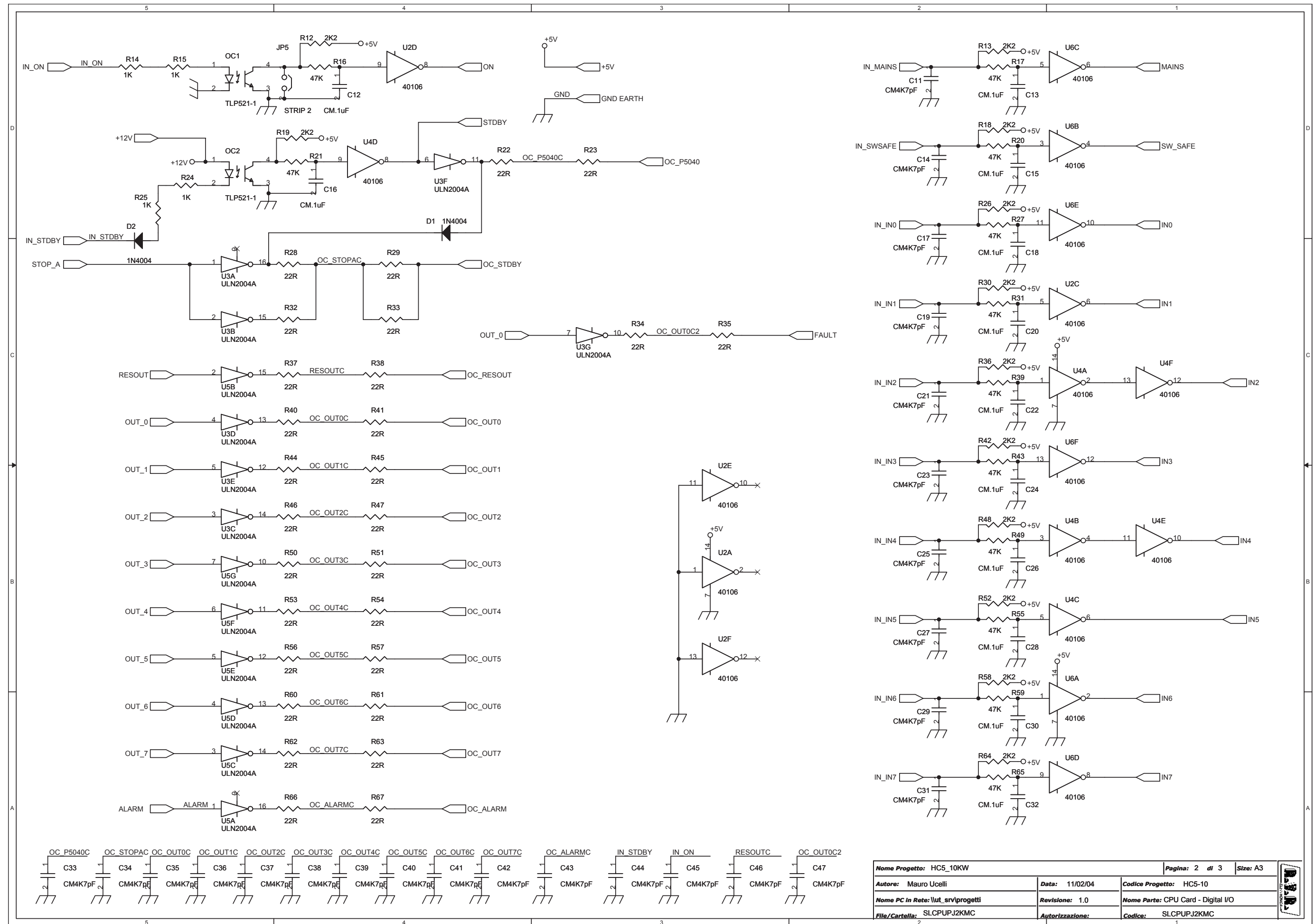

Nome Progetto: HC5_10KW		Pagina: 2 di 3		Size: A3
Autore: Mauro Ucelli		Data: 11/02/04	Codice Progetto: HC5-10	
Nome PC in Rete: \\ut_srv\progetti		Revisione: 1.0	Nome Parte: CPU Card - Digital I/O	
File/Cartella: SLCPUJ2KMC		Autorizzazione:	Codice: SLCPUJ2KMC	

CPU Card
CPUPJ2KMC

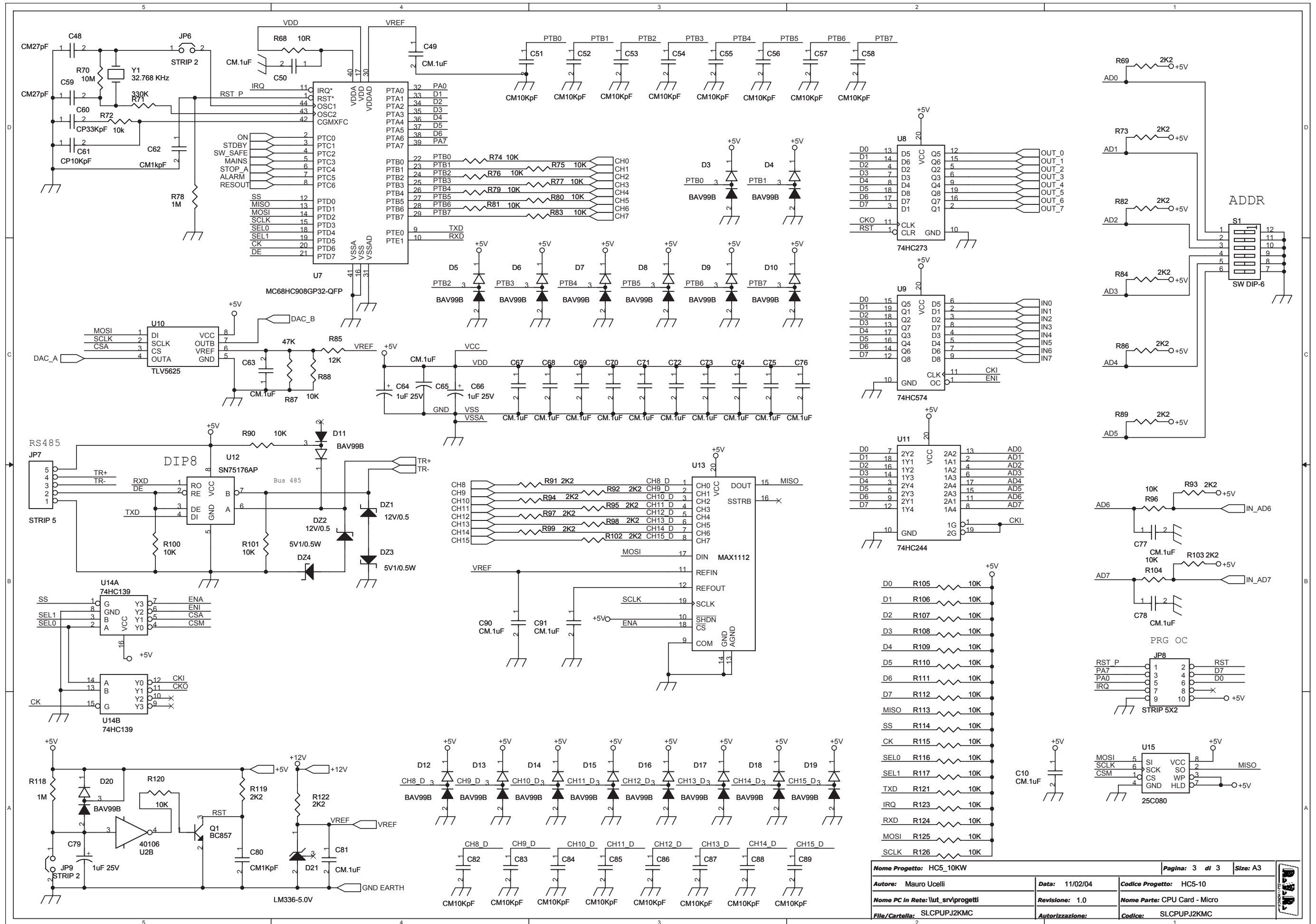

Nome Progetto: HC5_10KW		Pagina: 3 di 3		Size: A3
Autore: Mauro Ucelli	Data: 11/02/04	Codice Progetto: HC5-10		
Nome PC in Rete: lut_srviprogetti	Revisione: 1.0	Nome Parte: CPU Card - Micro		
File/Cartella: SLCPUPJ2KMC	Autorizzazione:	Codice: SLCPUPJ2KMC		

General Revised: Thursday, May 29, 2003
CSCPUPJ2KMC Revision: 1

Item	Quantity	Reference	Part
1	18	C1, C2, C51, C52, C53, C54, C55, C56, C57, C58, C82, C83, C84, C85, C86, C87, C88, C89	CM10KpF
2	4	C3, C64, C66, C79	1uF 25V
3	38	C4, C5, C6, C7, C8, C9, C10, C12, C13, C15, C16, C18, C20, C22, C24, C26, C28, C30, C32, C49, C50, C63, C65, C67, C68, C69, C70, C71, C72, C73, C74, C75, C76, C77, C78, C81, C90, C91	CM.1uF
4	25	C11, C14, C17, C19, C21, C23, C25, C27, C29, C31, C33, C34, C35, C36, C37, C38, C39, C40, C41, C42, C43, C44, C45, C46, C47	CM4K7pF
5	2	C48, C59	CM27pF
6	1	C60	CP33KpF
7	1	C61	CP10KpF
8	2	C62, C80	CM1KpF
9	2	DZ2, DZ1	12V/0.5
10	2	DZ4, DZ3	5V1/0.5W
11	2	D1, D2	1N4004
12	18	D3, D4, D5, D6, D7, D8, D9, D10, D11, D12, D13, D14, D15, D16, D17, D18, D19, D20	BAV99B
13	1	D21	LM336-5.0V
14	4	FIX1, FIX2, FIX3, FIX4	FIX35
15	1	JP1	CON20A
16	1	JP2	CON26A
17	2	JP4, JP3	STRIP8
18	3	JP5, JP6, JP9	STRIP 2
19	1	JP7	STRIP 5
20	1	JP8	STRIP 5X2
21	2	OC1, OC2	TLP521-1
22	1	Q1	BC857
23	5	R1, R14, R15, R24, R25	1K
24	4	R2, R4, R6, R11	100R
25	35	R3, R72, R74, R75, R76, R77, R79, R80, R81, R83, R88, R90, R96, R100, R101, R104, R105, R106, R107, R108, R109, R110, R111, R112, R113, R114, R115, R116, R117, R120, R121, R123, R124, R125, R126	10K
26	2	R71, R5	330K
27	15	R7, R9, R16, R17, R20, R21, R27, R31, R39, R43, R49, R55, R59, R65, R87	47K
28	2	R8, R10	10K5
29	30	R12, R13, R18, R19, R26, R30, R36, R42, R48, R52, R58, R64, R69, R73, R82, R84, R86, R89, R91, R92, R93, R94, R95, R97, R98, R99, R102, R103, R119, R122	2K2
30	28	R22, R23, R28, R29, R32, R33, R34, R35, R37, R38, R40, R41, R44, R45, R46, R47, R50, R51, R53, R54, R56, R57, R60, R61, R62, R63, R66, R67	22R
31	1	R68	10R
32	1	R70	10M
33	2	R118, R78	1M
34	1	R85	12K
35	1	S1	SW DIP-6
36	1	U1	TL074

Item	Quantity	Reference	Part
37	3	U2, U4, U6	40106
38	2	U5, U3	ULN2004A
39	1	U7	MC68HC908GP32-QFP
40	1	U8	74HC273
41	1	U9	74HC574
42	1	U10	TLV5625
43	1	U11	74HC244
44	1	U12	SN75176AP
45	1	U13	MAX1112
46	1	U14	74HC139
47	1	U15	25C080
48	1	Y1	32.768 KHz

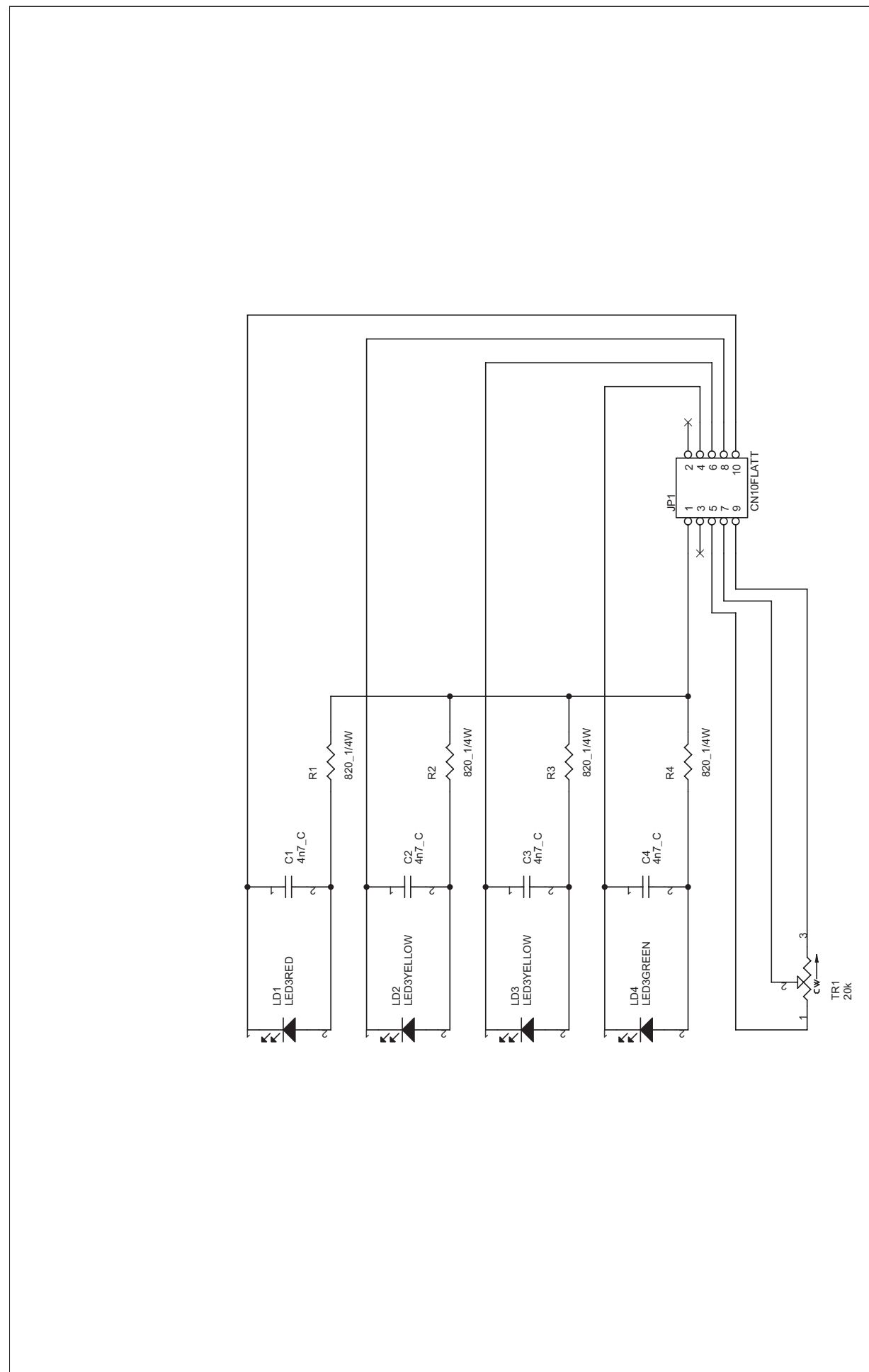
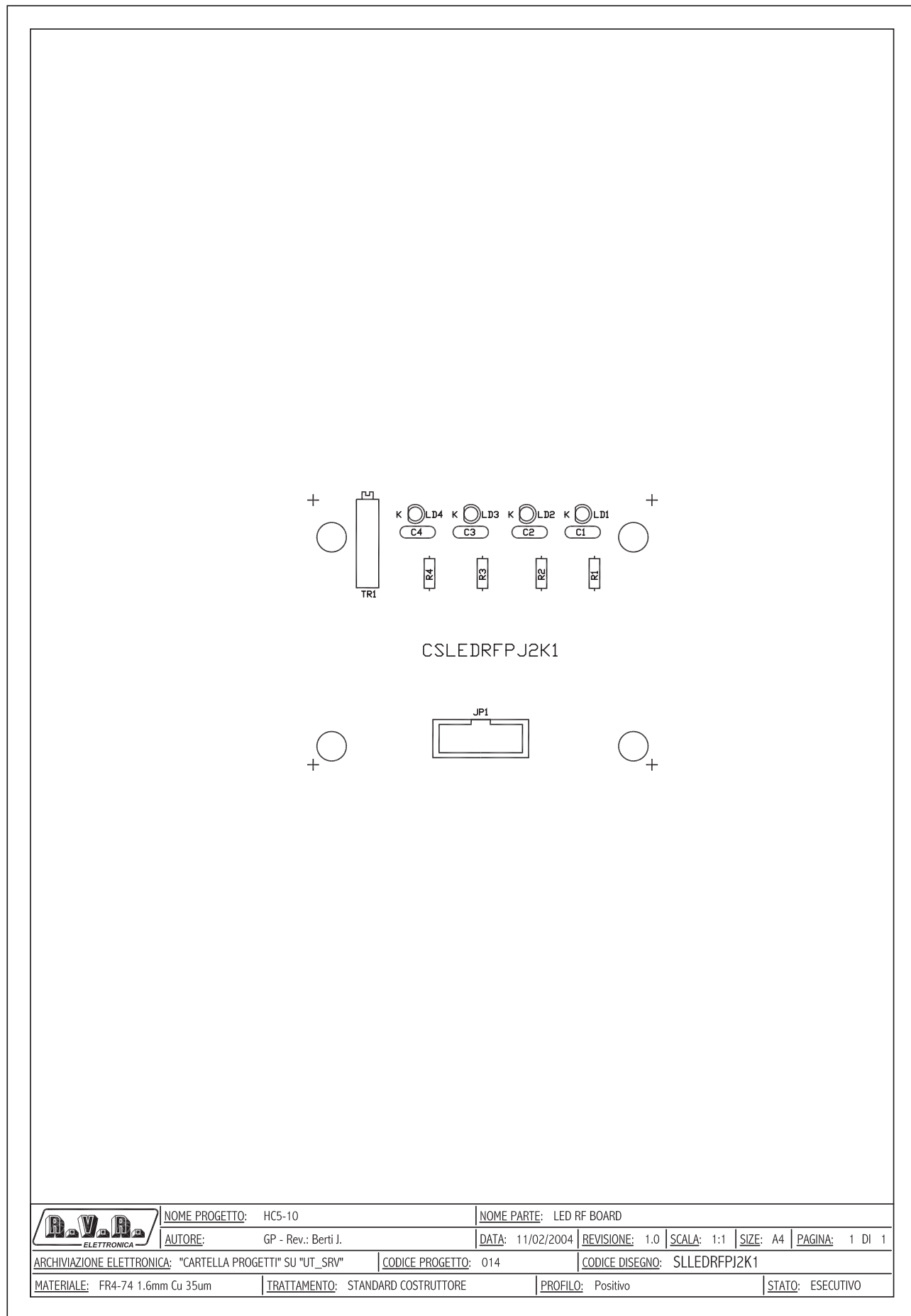



Nome Progetto: HC5-10	Pagina: 1	di 1	Size: A4
Autore: Mauro Ucelli	Data: 28/02/02	Codice Progetto: 014	
Nome PC in Rete: Mauro2	Revisione: 1.0	Nome Parte: LEDs board RF section	
File/Cartella: j:\c5\08\realizzazioni\Elettro\CSLEDRFPJ2K1	Autonizzazioni:	Codice: SLLEDRFPJ2K1	

	NOME PROGETTO: HC5-10	NOME PARTE: LED RF BOARD	
	AUTORE: GP - Rev.: Berti J.	DATA: 11/02/2004	REVISIONE: 1.0
ARCHIVIAZIONE ELETTRONICA: "CARTELLA PROGETTI" SU "UT_SRV"	CODICE PROGETTO: 014	CODICE DISEGNO: SLLEDRFPJ2K1	SCALA: 1:1
MATERIALE: FR4-74 1.6mm Cu 35um	TRATTAMENTO: STANDARD COSTRUTTORE	PROFILO: Positivo	STATO: ESECUTIVO

LEDs board RF section Revised: Thursday, February 26, 2004
 SLLEDRFPJ2K1 Revision: 1.0
 HC5-10

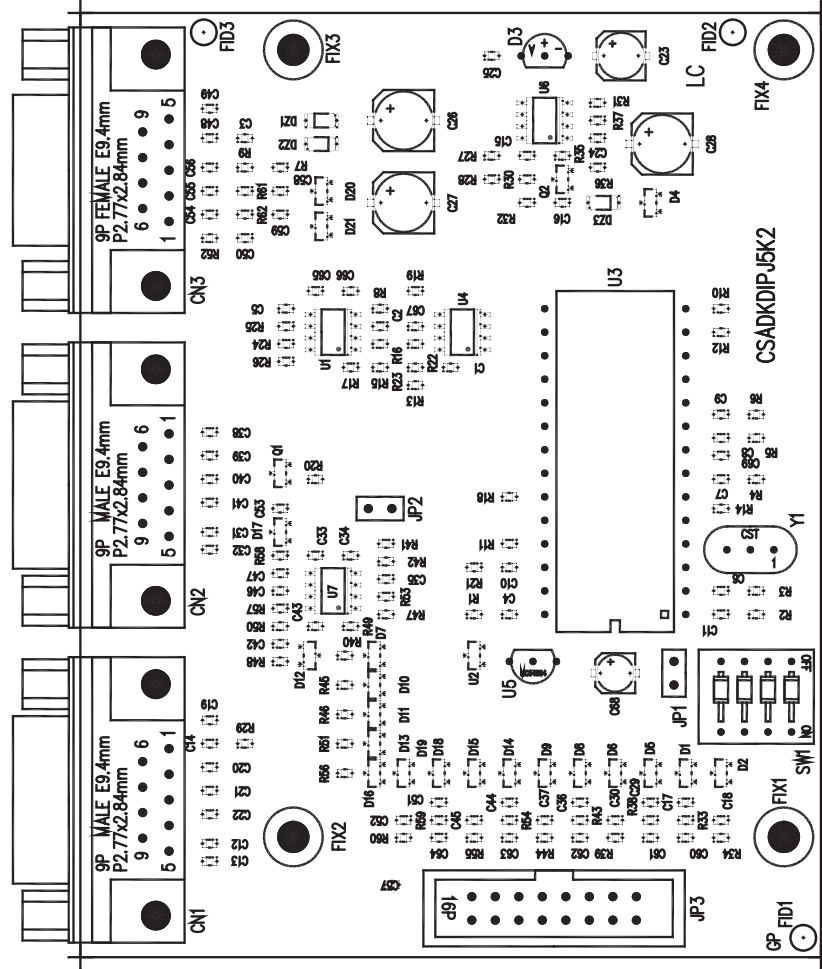
Item	Quantity	Reference	Part	Description
1	4	C1, C2, C3, C4	4n7_C	COND.CER. 4NF7 P5,08 10% 60V N150
2	1	JP1	CN10FLATT	Connettore 10p per Flatt diritto
3	1	LD1	LED3RED	Diodo LED 3mm Rosso
4	2	LD2, LD3	LED3YELLOW	Diodo LED 3mm Giallo
5	1	LD4	LED3GREEN	Diodo LED 3mm Verde
6	4	R1, R2, R3, R4	820_1/4W	Resistenza 820 Ohm 1/4W
7	1	TR1	20k	Trimmer multigiri 20k reg. di lato in conten. allungato (L623)



	NOME PROGETTO: HC5-10	NOME PARTE: KDI M-CONTROLLER
AUTORE: GP - Rev.: J. Berti	DATA: 11/02/2004	REVISIONE: 1.0
ARCHIVIAZIONE ELETTRONICA: "CARTELLA PROGETTI" SU "UT_SRV"	CODICE PROGETTO: 014	SCALA: 1:1
MATERIALE: FR4-74 1.6mm Cu 35um	TRATTAMENTO: STANDARD COSTRUTTORE	PROFILO: Positivo
		STATO: ESECUTIVO
		SIZE: A4
		PAGINA: 1 DI 1
		CODICE DISEGNO: SLADKDIPJ5K2

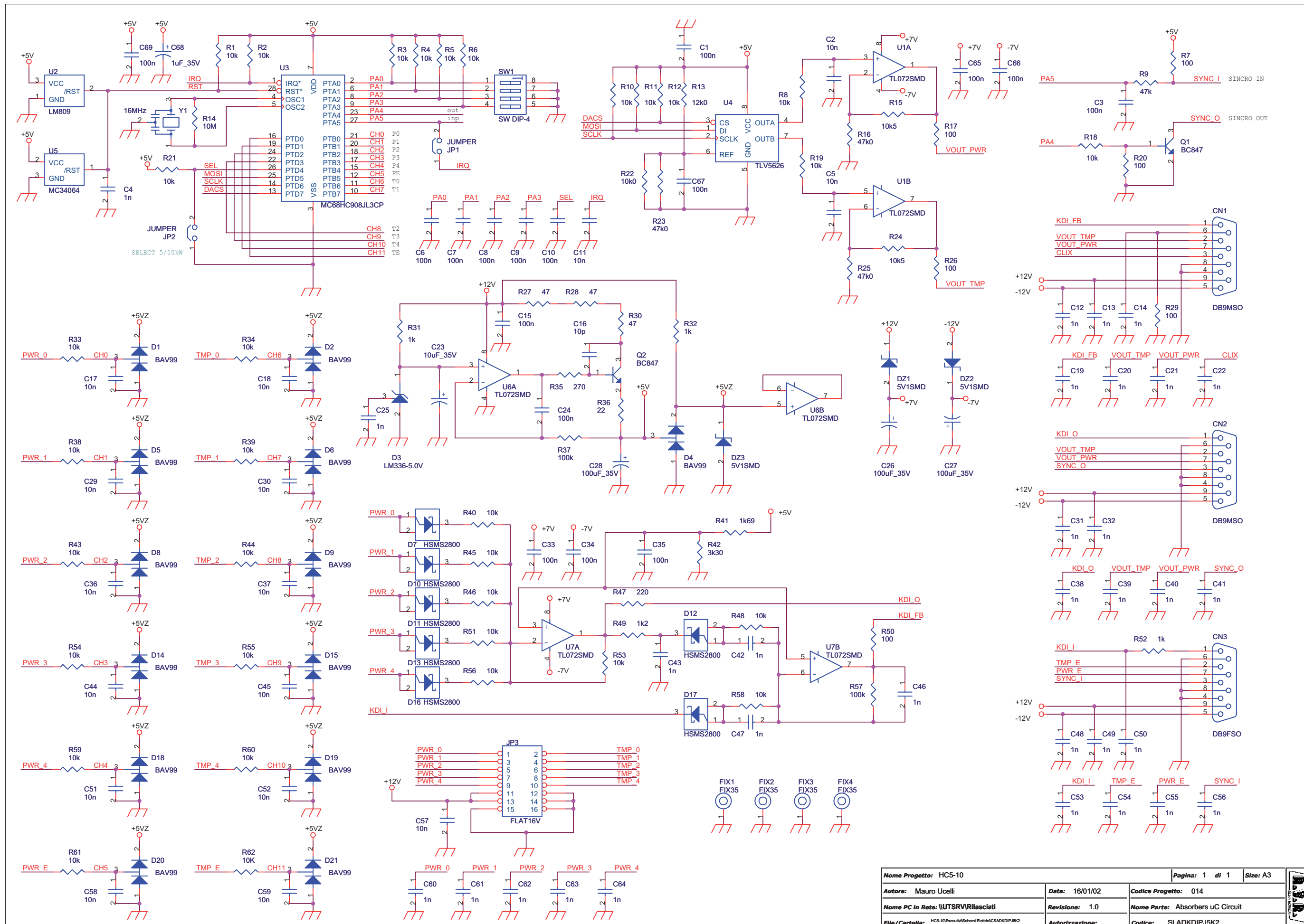

Nome Progetto: HC5-10	Pagina: 1 di 1	Size: A3
Autore: Mauro Ucelli	Data: 16/01/02	Codice Progetto: 014
Nome PC in Rete: \UTSRV\Rilasciati	Revisione: 1.0	Nome Parte: Absorbers uC Circuit
File/Cartella: HC5-10\Execu\W\Schemi Elettrici\SLADKDIPJ5K2	Autorizzazione:	Codice: SLADKDIPJ5K2

Absorbers μ C Circuit Revised: Monday, February 11, 2002

CSADKDIPJ5K2 Revision: 1.0

PJ5000MC

PJ5000MC_Code

Mauro Ucelli

Item	Quantity	Reference	Part
1	2	CN1, CN2	DB9MSO
2	1	CN3	DB9FSO
3	16	C1, C3, C6, C7, C8, C9, C10, C15, C24, C33, C34, C35, C65, C66, C67, C69	100n
4	16	C2, C5, C11, C17, C18, C29, C30, C36, C37, C44, C45, C51, C52, C57, C58, C59	10n
5	31	C4, C12, C13, C14, C19, C20, C21, C22, C25, C31, C32, C38, C39, C40, C41, C42, C43, C46, C47, C48, C49, C50, C53, C54, C55, C56, C60, C61, C62, C63, C64	1n
6	1	C16	10p
7	1	C23	10uF_35V
8	3	C26, C27, C28	100uF_35V
9	1	C68	1uF_35V
10	3	DZ1, DZ2, DZ3	5V1SMD
11	13	D1, D2, D4, D5, D6, D8, D9, D14, D15, D18, D19, D20, D21	BAV99
12	1	D3	LM336-5.0V
13	7	D7, D10, D11, D12, D13, D16, D17	HSMS2800
14	4	FIX1, FIX2, FIX3, FIX4	FIX35
15	2	JP2, JP1	JUMPER
16	1	JP3	FLAT16V
17	2	Q2, Q1	BC847
18	33	R1, R2, R3, R4, R5, R6, R8, R10, R11, R12, R18, R19, R21, R33, R34, R38, R39, R40, R43, R44, R45, R46, R48, R51, R53, R54, R55, R56, R58, R59, R60, R61, R62	10k
19	6	R7, R17, R20, R26, R29, R50	100
20	1	R9	47k
21	1	R13	12k0
22	1	R14	10M
23	2	R15, R24	10k5
24	3	R16, R23, R25	47k0
25	1	R22	10k0
26	3	R27, R28, R30	47
27	3	R31, R32, R52	1k
28	1	R35	270
29	1	R36	22
30	2	R57, R37	100k
31	1	R41	1k69
32	1	R42	3k30
33	1	R47	220
34	1	R49	1k2
35	1	SW1	SW DIP-4
36	3	U1, U6, U7	TL072SMD
37	1	U2	LM809
38	1	U3	MC68HC908JL3CP
39	1	U4	TLV5626
40	1	U5	MC34064
41	1	Y1	16MHz

Note:

1) Le resistenze di precisione 5% possono essere sostituite con resistenze 1% di pari valore.

2) I componenti LM809 e MC34064 sono alternativi,