

VJ2000

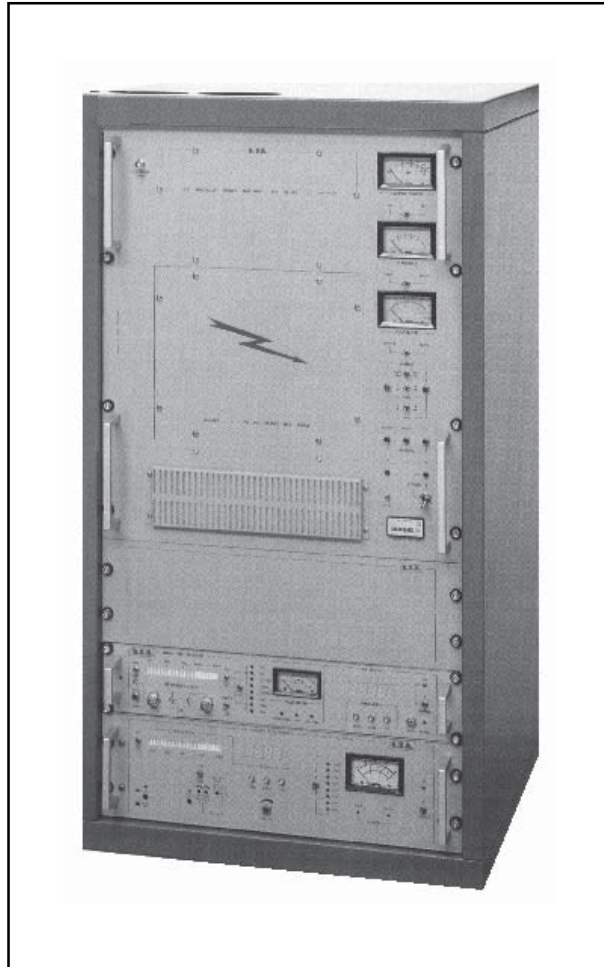

User Manual

Prodotto da  Italia



VJ2000 - User Manual
Version 4.0

© Copyright 1995-2001
R.V.R. Elettronica SpA
Via del Fonditore 2/2c - 40138 - Bologna (Italia)
Telefono: +39 051 6010506
Fax: +39 051 6011104
Email: info@rvr.it
Web: www.rvr.it

All rights reserved

Printed and bound in Italy. No part of this manual may be reproduced, memorized or transmitted in any form or by any means, electronic or mechanic, including photocopying, recording or by any information storage and retrieval system, without the permission of the copyright owner.



Notification of intended purpose and limitations of product use

This product is a FM transmitter intended for FM audio broadcasting. It utilises operating frequencies not harmonised in the intended countries of use.

The user must obtain a license before using the product in intended country of use. Ensure respective country licensing requirements are complied with.

Limitations of use can apply in respect of operating frequency, transmitter power and/or channel spacing.

Declaration of Conformity

Hereby, R.V.R. Elettronica SpA, declares that this FM transmitter is in compliance with the essential requirements and other relevant provisions of Directive 1999/5/EC.



This page intentionally left blank

Table of Content

1. Preliminary instructions	1
2. Warranty	2
3. First Aid	4
3.1 Treatment of electrical shocks	4
3.1.1 If victim is not responsive	4
3.1.2 If victim is responsive	5
3.2 Treatment of electrical Burns	5
3.2.1 Extensive burned and broken skin	5
3.2.2 Less severe burns (1st and 2nd degree)	5
4. General Description	6
4.1 Mechanical Description	6
4.2 Electrical Description	6
4.3 Controls and Indicators	6
4.4 Protection System	7
4.5 Specifications	7
5. Electrical Description	10
5.1 Introduction	10
5.2 Power Supply	10
5.3 Protection Card	10
5.4 Tube	10
6. Installation Procedure	25
6.1 Introduction	25
6.2 Unpacking	25
6.3 Fitting the Tube	25
6.4 Connection and Setup Procedures	25
6.5 Fault Finding during the Setup Procedure	27
7. Maintenance Procedure	29
7.1 Safety Procedures	29
7.2 Routine Maintenance	29
7.3 Replacements of the Components	29
7.4 Replacement of the Tube	30
7.5 Changing the Rear Grill Air Filter	30
7.6 Changing the Front Grill Air Filter	30
8. Calibration Procedure	31
8.1 Frequency Changes	31
8.2 Calibration of the Protection Board	32
8.3 Calibration of the Grid Current Meter (IG)	34
8.4 Calibration of Anode Current Measurement (IA)	34
8.5 Calibration of Heater Voltage Measurement (HEATER)	34
8.6 Calibration of Plate Voltage Measurement (PLATE)	35

8.7	Calibration of the PWR Meter (FWD-PWR LECTURE)	35
8.8	Calibration of the PWR Meter (REF-PWR LECTURE)	36
9.	Connectors Description	41
9.1	Telemetry Connector	41
10.	Telemetry Card Option	42
10.1	Calibration of the Voltages on the Telemetry connector	42
10.2	Wiring Connections details	42
10.3	General Verifications	43
Appendix		44

1. Preliminary instructions

This manual is written as a general guide for those having previous knowledge and experience with this kind of equipment.

It is not intended to contain a complete statement of all safety rules which should be observed by personnel in using this or other electronic equipment.

The installation, use and maintenance of this piece of equipment involve risks both for the personnel performing them and for the device itself, that shall be used only by trained personnel.

R.V.R. doesn't assume responsibility for injury or damage resulting from improper procedures or practices by untrained/unqualified personnel in the handling of this unit.

Please observe all local codes and fire protection standards in the operations of this unit.



WARNING: always disconnect power before opening covers or removing any part of this unit.

Use appropriate grounding procedures to short out capacitors and high voltage points before servicing.



WARNING: This is a "CLASS A" equipment. In a residential place this equipment can cause hash. In this case can be requested to user to take the necessary measures.

R.V.R. Elettronica SpA reserves the right to modify the design and/or the technical specifications of the product and this manual without notice.

2. Warranty

Any product of **R.V.R. Elettronica** is covered by a 12 (twelve) month warranty.

For components like tubes for power amplifiers, the original manufacturer's warranty applies.

R.V.R. extends to the original end-user purchaser all original manufacturers warranties which are transferable and all claims are to be made directly to R.V.R. per indicated procedures.

R.V.R.'s warranty shall not include:

- 1) Re-shipment of the unit to R.V.R. for repair purposes
- 2) Any unauthorized repair/modification
- 3) Incidental/consequential damages as a result of any defect
- 4) Nominal non-incidentual defects
- 5) Re-shipment costs or insurance of the unit or replacement units/parts

Warranty shall come into force from invoice date and for the period of the manufactures warranty.

Any damage to the goods must be reported to the carrier in writing on the shipment receipt.

Any discrepancy or damage discovered subsequent to delivery, shall be reported to R.V.R. within five (5) days from its receipt.

To claim your rights under this warranty:

- a. Contact the dealer or distributor where you purchased the unit. Describe the problem and ask if he has an easy solution. Dealers and Distributors are supplied with all the information about problems that may occur and usually they can repair the unit quicker than what the manufacturer could do. Very often installing errors are discovered by dealers.
- b. If your dealer cannot help you, contact R.V.R. in Bologna and explain the problem. If it is decided to return the unit to the factory, R.V.R. will mail you a regular authorization with all the necessary instructions to send back the goods.
- c. When you receive the authorization, you can return the unit. Pack it carefully for the shipment, preferably using the original packing and seal the package perfectly. The customer always assumes the risks of loss (i.e., R.V.R. is never responsible for damage or loss), until the package reaches R.V.R. premises. For this reason, we suggest you to insure the goods for the whole value. Shipment must be effected C.I.F. (PREPAID) to the address specified by R.V.R.'s service manager on the authorization.



DO NOT RETURN UNITS WITHOUT OUR AUTHORIZATION AS THEY WILL BE REFUSED.

- a Be sure to enclose a written technical report where mention all the problems found and a copy of your original invoice establishing the starting date of the warranty.

Replacement and warranty parts may be order from the following address. Be sure to include the equipment model and serial number as well as part description and part number.



R.V.R. Elettronica SpA
Via del Fonditore, 2/2c
40138 BOLOGNA
ITALY
Tel. +39 051 6010506

3. First Aid

The personnel employed in the installation, use and maintenance of the device, shall be familiar with theory and practice of first aid.

3.1 Treatment of electrical shocks

3.1.1 If victim is not responsive

follow the A-B-C's of basic life support

- Place victim flat on his back on a hard surface.
- Open airway: lift up neck, push forehead back
- clear out mouth if necessary and observe for breathing
- if not breathing, begin artificial breathing (Figure 2): tilt head, pinch nostrils, make airtight seal, four quick full breaths. Remember mouth to mouth resuscitation must be commenced as soon as possible

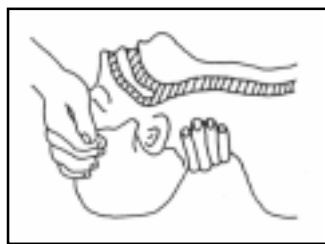

Figure 1



Figure 2

- Check carotid pulse (**Figura 3**); if pulse is absent, begin artificial circulation(**Figura 4**) depressing sternum 1 1/2" TO 2" (**Figure 5**).



Figura 3



Figura 4



Figura 5

- APPROX. 80 SEC. : ONE RESCUER, 15 COMPRESSIONS
- APPROX. 60 SEC.: TWO RESCUERS, 5 COMPRESSIONS, 1 BREATH
- DO NOT INTERRUPT RHYTHM OF COMPRESSIONS WHEN SECOND PERSON IS GIVING BREATH
- Call for medical assistance as soon as possible.

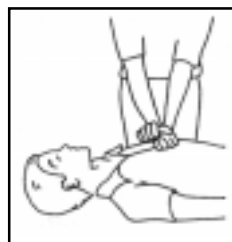
3.1.2 If victim is responsive

- Keep them warm
- Keep them as quiet as possible
- Loosen their clothing (a reclining position is recommended)
- Call for medical help as soon as possible

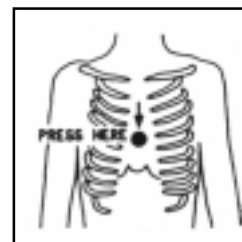
3.2 Treatment of electrical Burns

3.2.1 Extensive burned and broken skin

- Cover area with clean sheet or cloth (Cleansed available cloth article).
- Do not break blisters, remove tissue, remove adhered particles of clothing, or apply any salve or ointment.
- Treat victim for shock as required.
- Arrange transportation to a hospital as quickly as possible.
- If arms or legs are affected keep them elevated

If medical help will not be available within an hour and the victim is conscious and not vomiting, give him a weak solution of salt and soda: 1 level teaspoonful of salt and 1/2 level teaspoonful of baking soda to each quart of water (neither hot or cold). Allow victim to sip slowly about 4 ounces (half a glass) over a period of 15 minutes. Discontinue fluid if vomiting occurs



Do not give alcohol

3.2.2 Less severe burns (1st and 2nd degree)

- Apply cool (not ice cold) compresses using the cleansed available cloth article.
- Do not break blisters, remove tissue, remove adhered particles of clothing, or apply salve or ointment.
- Apply clean dry dressing if necessary.
- Treat victim for shock as required.
- Arrange transportation to a hospital as quickly as possible
- If arms or legs are affected keep them elevated.

4. General Description

4.1 Mechanical Description

The VJ2000 is housed in a 19" rack-mountable frame, 20U high, of which 8U are free and may be used for an exciter, a receiver or other equipment.

All controls and switches are situated on the front panel together with two analog meters.

There are no connectors on the rear panel.

Both the cooling air inlet complete with fan and filter, and the power cable entry hole may be found on this panel.

A flue may be found on the top of the unit for the expulsion of hot air used for cooling the unit, together with the RF output connector (to be connected to the antenna).

4.2 Electrical Description

The VJ2000 is a tube amplifier with an earthed grid allowing a wide-band input (no calibration across the band) from 87.5 to 108MHz.

This amplifier is able to generate an output power of over 2KW from an input power of approx. 60W. The amplifier features motorized anode and load matching across the entire operational band.

The VJ2000 is available in single phase version or three phase version.

4.3 Controls and Indicators

Three analog meters are present on the front panel; one measures direct and reflected power output (2 Fig.1), one measures plate and grid currents (4 Fig.1), the last measures heater and plate voltage (6 Fig.1).

The meter for the measurements of the direct and reflected power has two scales too; one for 250W f.s. to measure reflected power output, the other for 2.5KW f.s. to measure direct power output.

The meter for the measurements of the grid and plate currents has two scales too; one for 1A f.s. to measure plate current, the other for 100mA f.s. to measure grid current.

The meter for the measurements of the heater and plate voltage has two scales too; one for 5KV f.s. to measure plate voltage, the other for 10V f.s. to measure heater voltage.

For each of these meters there are the relative reading selector

(3,5 and 7 Fig.1).

In central position there are some switches and led indicators that concern to the plate and

load tuning: the two led indicators signal respectively the stop for the plate tuning at 87.5 MHz (9 Fig.1) and at 108 MHz (10 Fig.1), while the three selectors are used respectively for to enable the engines of tuning (8 Fig.1), for the plate tuning (11 Fig.1) and for the load tuning (12 Fig.1).

Then there are three led indicators that signal alarms: for an excess of S.W.R. (13 Fig.1), for insufficient fan pressure (15 Fig.1) and for an excess of grid current (14 Fig.1).

The following are present on the front panel: an HT indicator (16 Fig.1) which signals that the high voltage supply is active; a switch to activate the HT supply, or put the unit in stand-by (19 Fig.1); an on-off switch (18 Fig.1) and corresponding indicator (17 Fig.1); an hours counter (20 Fig.1) to show the total number of hours that the unit has been operational.

4.4 Protection System

The VJ2000 features protection against: excess VSWR, excess grid current, opening of panels with the unit active, and insufficient ventilation.

Under abnormal conditions the unit will be automatically deactivated; after 90 seconds the protection system will re-activate the unit if the condition has returned to normal, unless a panel is still open or the cooling system lacks sufficient pressure.

In this event, the procedure is repeated four times, after which the unit will remain deactivated for 15 minutes.

If, after 15 minutes, the condition is still present, four more switch-on attempts are made, after which the unit is shut down indefinitely.

Should, during these cycles, the fault condition disappear and the protection system succeed in re-activating the unit for more than 15 minutes, the fault condition counter will be reset to zero.

N.B. The times indicated above are approximate and may vary considerably.

4.5 Specifications

Please refer to Table A for the electrical specification and Table B for dimensional and environmental specifications.

TABLE A
ELECTRICAL SPECIFICATIONS

Power Supply	Single phase: 220-240V, 50-60 Hz Three phase: 220-240V, 50-60 Hz 380-415V, 50-60 Hz
Frequency Range	87.5-108 MHz (others on request)
Output Power	1800-2000 Watts
RF Output Impedance	50 Ohm
RF Output Connector	LC Connector EIA 7/8" Flange EIA 7/16" Flange
RF Input Impedance	50 Ohm
RF Input Connector	"N" type connector
RF Input Power	50W typical, max 70W
Tube	EIMAC 3CX1500A7 Standard Version
Cooling System	Forced ventilation
Harmonic and Spurious Signal Suppression:	Meets or exceeds FCC and CCIR regulations

TABLE B**DIMENSIONAL AND ENVIRONMENTAL SPECIFICATIONS**

Rack Dimensions:	540 mm (21.26") W 590 mm (23.23") D 965 mm (37.99")H
Panel Dimensions:	483 mm (19") W 533.4 mm (21") H
Weight:	approx 130 Kg
Operating Temperature Range:	from -10° to +50°C
Maximum Humidity:	95% non-condensing

5. Electrical Description

5.1 Introduction

This section describes in detail, the operation of the VJ2000.

For ease of description, the unit has been divided into sections, each of which is described in detail, below.

5.2 Power Supply

The power supply, accessible via the rear panel, has been designed to be both rugged and at the same time simple to maintain, allowing easy access to every component thus easing repair work.

The power supply features a PI filter after the rectifying stage which attenuates spurious components.

Two fuses provide overload protection.

The power supply comprises three separate transformers: the largest supplies the tube anode, a toroidal transformer supplies the tube's filament (this is found towards the rear of the RF chamber) and lastly an auxiliary supplies various functions such as relays and the protection system.

This power supply is designed to work at single phase voltages (three phase is available on request).

5.3 Protection Card

This card is mounted in a metal box and fixed to the right-hand side of the RF chamber's chassis (5 Photo 2). This sub-unit has three alarm inputs which carry the signal to a comparator which compares them to a pre-defined threshold. Should one of these inputs exceed the alarm threshold, the amplifier is deactivated and a counter is started.

If the fault condition does not disappear within the period defined by the counter, the unit is shut down indefinitely.

5.4 Tube

The ceramic/metal power triode 3CX800A7 has been designed to work in AB₂ class amplifiers, in class B cathode-driven amplifiers, in audio or RF applications including the VHF band, or in class C cathode-driven, anode-modulated RF amplifiers.

As linear amplifiers, they feature high power gain with low levels of intermodulation.

For the tube specification, see Table C.

TABLE C

TUBE SPECIFICATIONS

Model	3CX500A7	
Anode Dissipation	1500W approx.	
Grid Dissipation:	25W approx.	
Max Frequency	250 MHz	
Cooling System:	Forced ventilation	
Filament Voltage	5.0V	
Filament Current	10.5A	
Capacitance with Grounded Cathode	Input:	38.5 pF
	Output:	0.1 pF
	Input/Output:	10.2 pF
Capacitance with Grounded Grid	Input:	38.5 pF
	Output:	10.2 pF
	Input/Output:	0.1 pF
Amplification Factor	200	
Transconductance	55.000 μ mhos	
Recommended Socket for Grounded Grid Operation	SK2210	
Recommended Socket for Grounded Cathode Operation	SK2200	
Recommended Flue	SK2216	
Maximum Anode and Seal Core Temperature	250°C	
Maximum Length:	102.2 mm (4.02")	
Maximum Diameter:	85.80 mm (3.38")	
Weight	0.7 Kg (1.6oz)	
Operational Position	Any	

TABLE D

BLOWER TECHNICAL SPECIFICATIONS

Model	Type	G2E 180 - AA 03 - 01
Voltage		220 V
Frequency		50-60 Hz
Air Volume		535 m ³ /h
Speed		2450 min ⁻¹
Input		300 W
Current Consumption		1.38 A
Capacitor		8 μF
Noise Level		66 dBA
Type of enclosure		IP 44
Weight Approx.		5.4 Kg

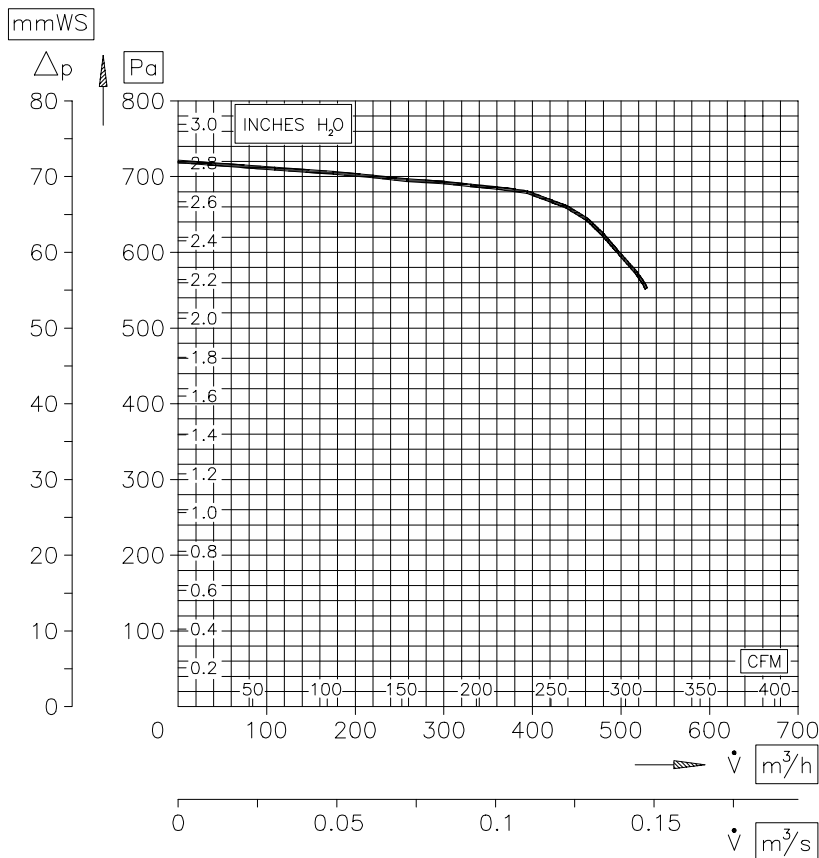

FRONT PANEL VIEW DESCRIPTION (FIG. 1)

1	R.F. TEST -60dB	-60dB with respect to the output level.
2	OUTPUT POWER	Analog meter for the measurement of direct and reflected output power.
3	DIR/REF	Switch for the selection of direct or reflected power measurement.
4	CURRENTS	Analog meter for the measurement of anode and grid currents.
5	GRID/PLATE	Switch for the selection of grid or anode current measurement.
6	VOLTMETER	Analog meter for the measurement of plate and heater voltages
7	HEATER/PLATE	Switch for the selection of heater or plate voltage measurement.
8	TUNING	Motorized tuning switch.
9	LED "-" (87.5)	Led to indicate that tuning has reached end of range at 87.5 MHz. Off signifies end of range.
10	LED "+" (108)	Led to indicate that tuning has reached end of range at 108 MHz. Off signifies end of range.
11	PLATE	Anode tuning switch.
12	LOAD	Load matching control.
13	V.S.W.R.	Indicator showing excess V.S.W.R.
14	I.G.	Alarm indicator for excess grid current.
15	PRESS.	Indicator showing insufficient fan pressure.
16	H.T.	Indicator showing high voltage active.
17	ON	Power indicator.
18	POWER	Power on/off switch.
19	ST.BY.	Standby switch.
20	HOURS METER	Hour counter showing the total number of hours that the unit has been operational.

21	AIR FILTER	Air filter for power supply.
22	HT PANEL	Internal access to RF chamber.
23	RESTART	Alarms Reset (only in the version with telemetry option)
24	ALARMS CARD ON	Alarms Card On (only in the version with telemetry option)

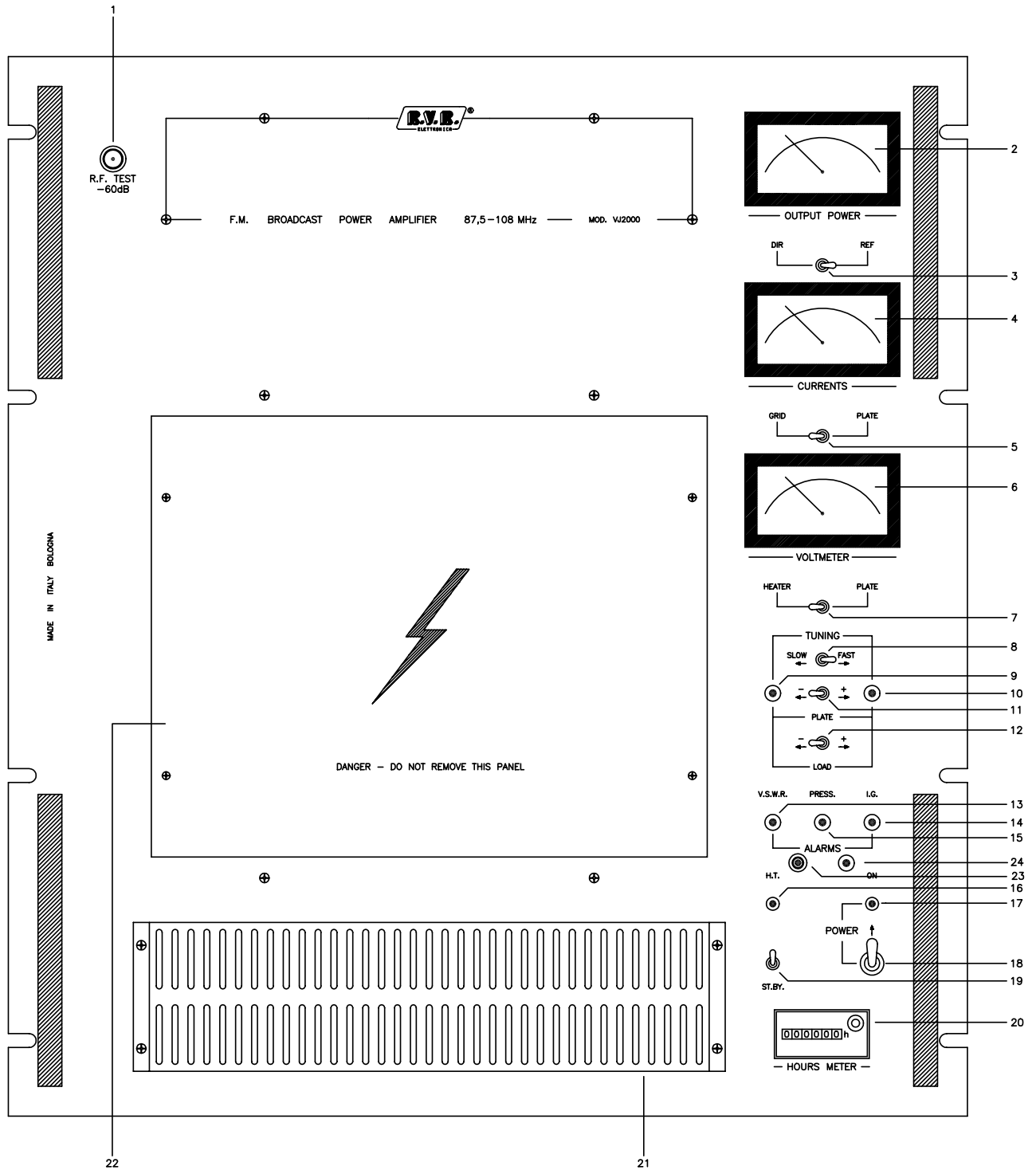

FIG. 1

VIEW DESCRIPTION OF SINGLE PHASE VERSION POWER SUPPLY (FIG. 2)

- 1 Auxiliary transformer
- 2 Anode supply filter capacitor
- 3 High voltage rectifier board
- 4 Anode supply transformer
- 5 High voltage resistor
- 6 Anode delay timer
- 7 Solenoid switch
- 8 Line fuse holders
- 9 Line power connector
- 10 Exciter supply
- 11 Earth
- 12 Chocke filter
- 13 Soft-Start resistor
- 14 Plate Voltage Measure Card

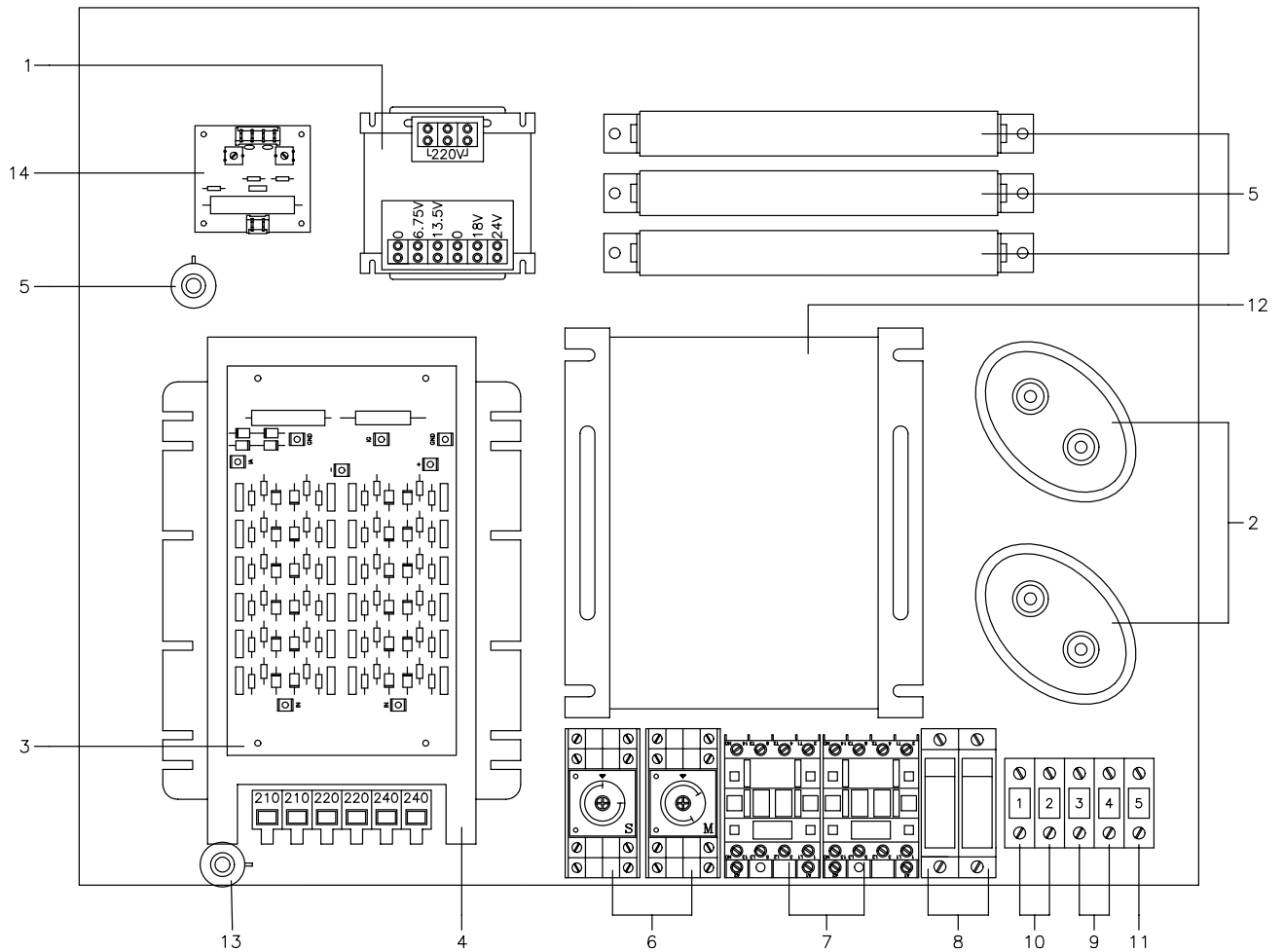

FIG. 2

R.F. CAVITY VIEW DESCRIPTION (PHOTO 1)

- 1 Cooling air outlet
- 2 Plate tuning control motor
- 3 Output connector (to antenna)
- 4 End of tuning range switch (87.5 Mhz)
- 5 Directional coupler for output power
measurement
- 6 Line
- 7 Tube
- 8 End of tuning range switch (108 Mhz)
- 9 Low-pass filter
- 10 Teflon C capacitor
- 11 High voltage input connector
- 12 Load matching capacitor CV



FOTO 1

R.F. BLOCK VIEW 1 DESCRIPTION (PHOTO 2)

- 1 Plate tuning control motor
- 2 Cooling air outlet
- 3 Air Flow switch
- 4 Air-Blower
- 5 Alarms Card
- 6 Hours Meter

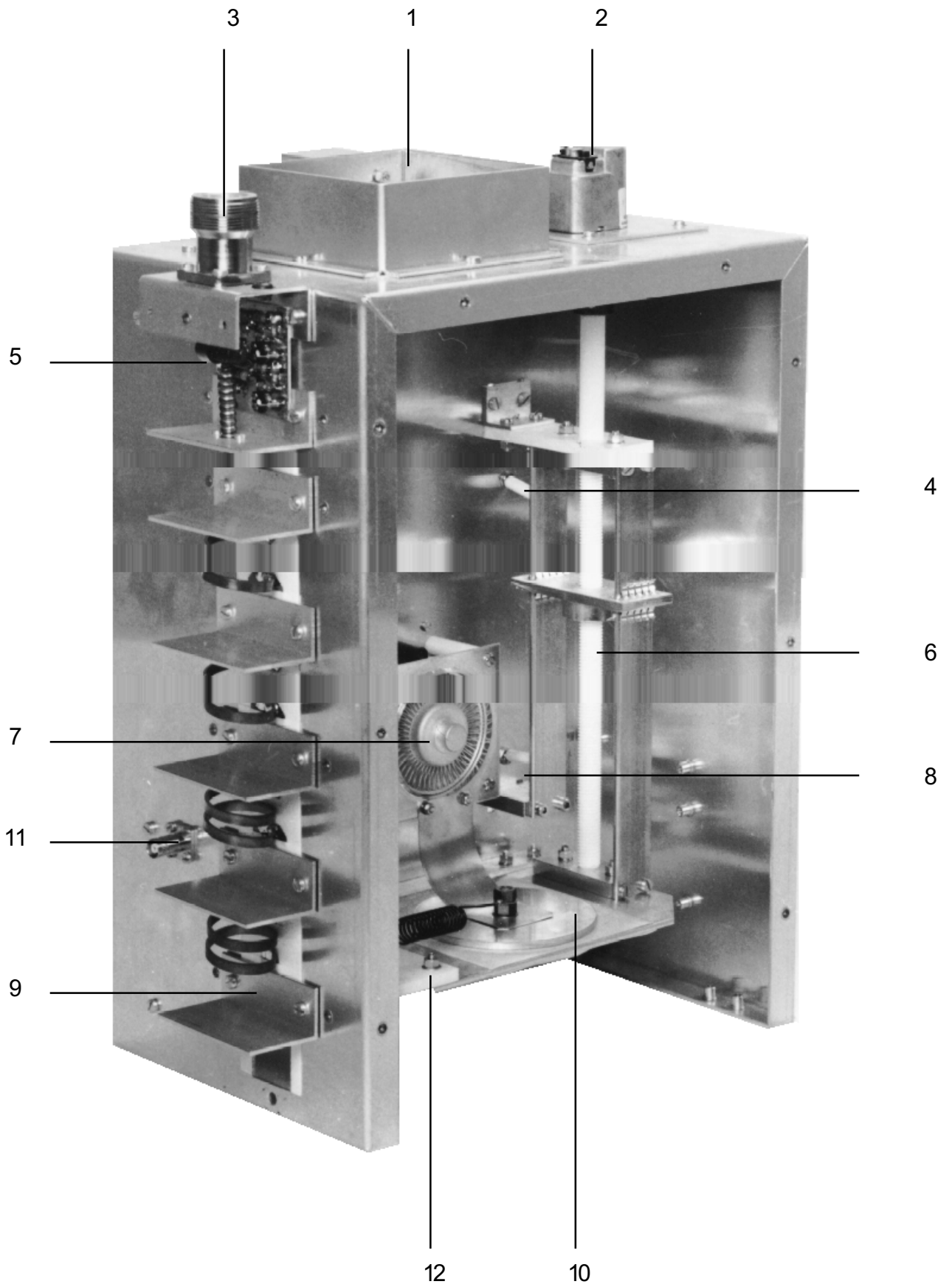

FOTO 2

R.F. BLOCK VIEW 2 DESCRIPTION (PHOTO 3)

- 1 Filament transformer
- 2 End of tuning range switch (87.5 Mhz)
- 3 Input Matching Card
- 4 Load tuning control motor
- 5 Tube Socket (Type SK2210)
- 6 End of tuning range switch (108 Mhz)
- 7 Multipolar circular connector
- 8 Voltmeter Card
- 9 Grid/Plate Current Meter Card
- 10 VJ2000's Driver Input Connector
- 11 VJ2000's Output Power Connector

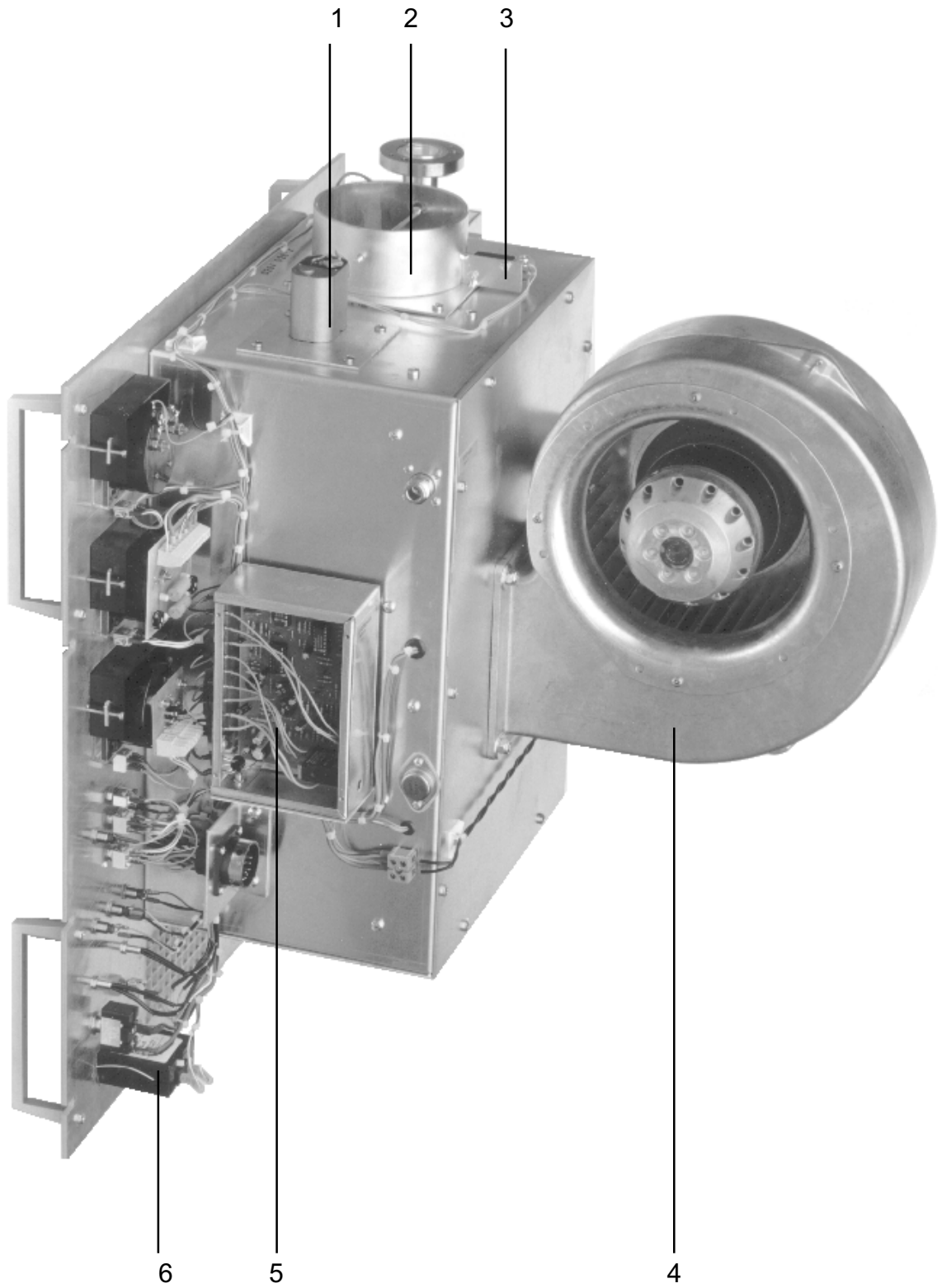

FOTO 3

TABLE E**TYPICAL VALUES OF THE OPERATING PARAMETERS**

<u>Power Voltage</u>	<u>Nominal Tension $\pm 5\%$</u>
	MAX COS-FI better than 0,9
Output Power	2KW
Input Power	55-65W
Anode Current	0,9A
Grid Current	< or = 60mA
Input SWR	2W max

6. Installation Procedure

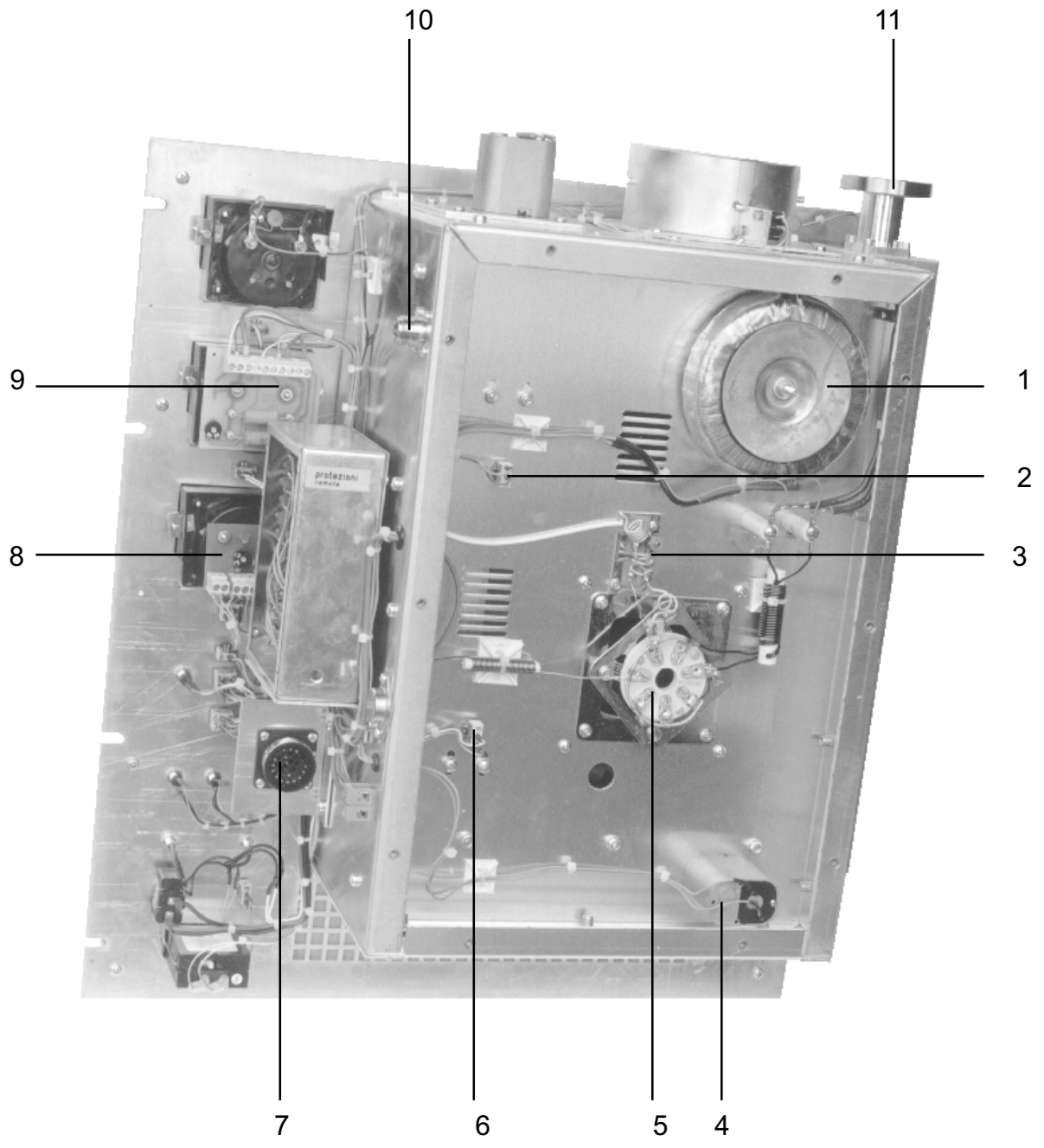
6.1 Introduction

This chapter contains information necessary for the installation and initial testing of the VJ2000 amplifier.

6.2 Unpacking

Remove the unit from its packing and, before any other operation, ensure that the unit has not suffered any damage in transit and that all its front panel controls are useable.

6.3 Fitting the Tube

To fit the tube follow the following instructions:

- 1) Unscrew the screws holding the high voltage front panel (22 Fig.1) and open it.
- 2) Check with care that the tube's pins are correctly aligned with its socket.
- 3) Insert the tube into its socket, pressing lightly and first rechecking the correct alignment of the pins.
- 4) Check that the tube is fully home in its socket, verifying the correct fit of the grid ring.
- 5) Shut the high voltage panel and re-fit all the screws.

6.4 Connection and Setup Procedures

To connect the unit, follow the following instructions:

- 1) Remove the rear panel.
- 2) Connect a cable of suitable dimensions (the unit can draw up to 20A) to the power input connector block.
- 3) Connect the exciter supply cable to the corresponding connector block, taking care to connect the earth (ground) to its correct connector.
- 4) Connect a 50 Ohm coaxial cable (type RG 213) fitted with an "N" type male connector to the input connector.
- 5) Connect an antenna or a dummy load with an impedance of 50 Ohm to the output connector type 7/8" (7/16" or LC on request).

Ensure that the coaxial cable has an impedance of 50 Ohm and that it can handle a continuous power of at least 2000 Watts.

- 6) After having connected the 220 V driver supply and an RF output connector to the driver, switch the VJ2000's POWER switch to OFF and the ST.BY. switch to ON.
- 7) Adjust the exciter power output control to minimum power.

- 8) Connect the line supply (220V \pm 5%) to the unit.
- 9) Switch the POWER switch to ON, the corresponding indicator will show the presence of the line supply in the unit and, at the same time the cooling fan will start.

Normally the PRESS. indicator will stay on for a few seconds before the fan has created sufficient air flow.

After 2-3 minutes of warming up, the HT indicator will light up; simultaneously the characteristic noise of the power solenoid will be heard indicating that the anode supply is active.

The driver will also be active.

The unit without excitation will absorb about 200 mA of anode current.

- 10) Switch the OUTPUT POWER switch to DIR and the CURRENTS switch to PLATE.
- 11) Adjust the exciter power control to obtain a anode current of 350/400 mA.
- 12) Using the TUNING switch, activate the tuning motors so that both green leds next to the PLATE control light up.

Holding the TUNING switch down, use the PLATE "+" or "-" control (the unit is factory-set to a frequency of 98 MHz) to tune the anode circuit.

"+" indicates an increase in frequency, and "-" a reduction in frequency.

If one of the leds switches off, this indicates that the end of the frequency range has been reached and that no more adjustment is available in that direction.

The OUTPUT POWER meter can be used to tune the anode circuit; maximum meter reading (maximum output power) corresponding to correct tuning.

- 13) The LOAD tuning procedure follows in a similar fashion: holding down the TUNING switch, adjust the LOAD control for maximum output power.

REPEAT STEPS 12 AND 13 SEVERAL TIMES TO OBTAIN THE OPTIMUM SETTINGS

- 14) Increase exciter power until an output power of 2000W is obtained and repeat steps 12 and 13.

Note: The driver power don't never must excess 60W, then the maximum Plate current is 900mA and the maximum Grig current is 60mA max

- 15) With output power at 2000 W, make small adjustments, as above, to minimize grid and anode currents; if necessary, reduce exciter power to maintain 2000 W of output power.

6.5 Fault Finding during the Setup Procedure

The following fault conditions may occur during the setup procedure:

1) THE RED LIGHT "PRESS." STAYS ON

Check that the rear air filter is not blocked and that there is at least 40/50 cm clearance between the rear of the unit and any obstructions such as a wall.

Check that the air exit flue is free from obstruction.

2) THE S.W.R. INDICATOR LIGHTS UP DURING THE TUNING PROCEDURE

Check for standing waves on the antenna with a wattmeter. The reading should be less than 150/160W.

3) THE GRID INDICATOR LIGHTS UP DURING THE CALIBRATION PROCEDURE

Reduce output power and carefully re-tune the output (LOAD and PLATE).

WARNING: The inside of the unit operates at high voltages which are dangerous and potentially lethal. For this reason the unit should only be operated with all its panels securely in place. The unit must be connected to a good earth. The unit should be operated in a well ventilated environment the hot air expelled by the unit will rapidly raise the temperature of a poorly ventilated environment with potentially damaging consequences. Should operation of the unit be inhibited by the protection system, do not attempt to re-activate the unit without carefully checking operating and environmental parameters.

4) THE EQUIPMENT DOESN'T SUPPLY THE NOMINAL POWER INDICATED ON THE TEST REPORT ALTHOUGH THE ADJUSTMENT OPERATION IS BEEN MADE CORRECTLY.

Verify that the line voltage, under load, has the nominal value $\pm 5\%$ max.

Verify the COS-FI value on the line; this value must be better than 0.9.

Otherwise correct the power factor of the line.

TABLE F

RECOMMEND TEST EQUIPMENT

INSTRUMENT TYPE	SUGGESTED MODEL	SPECIFICATIONS
Non Inductive	Bird	50 Ohm, 2.5KW cont.
Dummy Load	Mod. 8890-300	
Calibrated in-line Wattmeter with Sample	Bird Mod. 43	50 Ohm
Power Supply	Hewlett Packard Mod. 6002A	0-50V, 0-10A
Multimeter	Fluke Mod. 73	DC Voltage : max 1000V AC Volatge : max 750V DC Current : max 10A AC Current : max 10A Resistance : 32MOhm
High Voltage Probe for Fluke 73	Fluke Mod. 80K-40	Voltage Range: 1KV to 4KV dc or peak ac, 28kVrms ac

7. Maintenance Procedure

7.1 Safety Procedures

WARNING WARNING WARNING WARNING WARNING WARNING WARNING WARNING

When the amplifier is operational with the rear panel removed, lethal voltages are easily accessible.

Use properly insulated tools for any calibration work and do not make contact with any internal components.

Ensure that all high voltage components have been grounded (use an earthing stick).

Ensure that power has been disconnected from the unit before any maintenance work is started.

FIRST LEVEL OF MAINTENANCE

7.2 Routine Maintenance

The only routine maintenance required by the amplifier is periodic changing of the fan, air filter and removal of accumulated dust from inside the tube cavity and from the air filter.

The periods between routine maintenance will depend upon operating conditions, ambient temperature, ambient dust levels and humidity. It is advisable to carry out preventative checks at 3 month intervals and to change fans at least every 18 months, or before if they become noisy or show signs of wear.

Periodic replacement of the tube will also be necessary.

The operating life of the tube is very dependant upon operating conditions, for example: line voltage fluctuations over $\pm 5\%$, temperatures over $+30^{\circ}\text{C}$, high humidity, the presence of dust and incorrect calibration of the amplifier will all result in a greatly reduced tube life.

SECOND LEVEL OF MAINTENANCE

7.3 Replacements of the Components

N.B. TO RE-ASSEMBLE THE UNIT, SIMPLY REVERSE THE SEQUENCE OF OPERATIONS.

N.B. THE FOLLOWING PROCEDURE SHOULD ONLY BE CARRIED OUT BY QUALIFIED PERSONNEL USING THE CORRECT TOOLS AND EQUIPMENT. UNQUALIFIED OR INEXPERIENCED PERSONNEL NOT USING THE CORRECT TOOLS AND EQUIPMENT CAN EASILY CAUSE DAMAGE TO THE UNIT WHICH WILL IMMEDIATELY INVALIDATE THE GUARANTEE.

7.4 Replacement of the Tube

- 1) Ensure that the unit is isolated from its supply and, to avoid severe burns, that the tube that has to be replaced is no longer hot.

Ensure also that all terminals are at 0V, and if not use a shorting stick to remove any residual charge.

- 2) Undo the fixing screws holding the tube access panel (22 Fig.1) to the front panel and remove the access panel.
- 3) Remove the tube from its supporting socket, pulling in a direction perpendicular to its socket.
- 4) Should the tube prove excessively difficult to extract, unscrew the four screws holding the base of the anode contacts to the 4 teflon pillars.

Once the tube has been extracted from its socket, attempt to remove the anode contacts taking care not to damage them.

Re-mount the base on its pillars, without the tube.

- 5) To fit the new tube, follow the procedure from step 2 to step 5 in paragraph 3.3 FITTING THE TUBE.

7.5 Changing the Rear Grill Air Filter

- 1) Disconnect power from the unit.
- 2) Open the rear grill of the air filter by unscrewing the fixing screws.
- 3) Change the filter cleaning the inside with care.
- 4) Close the rear grill and tighten the fixing screws.
- 5) Reconnect power to the unit.

7.6 Changing the Front Grill Air Filter

- 1) Disconnect power from the unit.
- 2) Open the front grill of the air filter by unscrewing the fixing screws.
- 3) Change the filter cleaning the inside with care.
- 4) Close the rear grill and tighten the fixing screws.
- 5) Reconnect power to the unit.

8. Calibration Procedure

N.B. THE FOLLOWING PROCEDURE SHOULD ONLY BE CARRIED OUT BY QUALIFIED PERSONNEL USING THE CORRECT TOOLS AND EQUIPMENT. UNQUALIFIED OR INEXPERIENCED PERSONNEL NOT USING THE CORRECT TOOLS AND EQUIPMENT CAN EASILY CAUSE DAMAGE TO THE UNIT WHICH WILL IMMEDIATELY INVALIDATE THE GUARANTEE.

8.1 Frequency Changes

To change the operating frequency of a tube amplifier the following procedure is required:

- 1) Select the desired frequency on the exciter.
- 2) Reduce exciter power to minimum power.
- 3) Connect the line supply to the unit.
- 4) Switch the POWER switch to ON, the corresponding indicator will show the presence of the line supply in the unit and, at the same time the cooling fan will start.

Normally the PRESS. indicator will stay on for a few seconds before the fan has created sufficient air flow.

After 2/3 minutes of warming up, the HT indicator will light up; simultaneously the characteristic noise of the power solenoid will be heard indicating that the anode supply is active.

The driver will also be active. The unit without excitation will absorb about 200 mA of anode current.

- 5) Switch the OUTPUT POWER switch to DIR and the CURRENTS switch to PLATE.
- 6) Adjust the exciter power control to obtain an anode current of 350/400mA.
- 7) Using the TUNING switch, activate the tuning motors so that both green leds next to the PLATE control light up.

Holding the TUNING switch down, use the PLATE "+" or "-" control (the unit is factory set to a frequency of 98 MHz) to tune the plate circuit.

"+" indicates an increase in frequency and "-", a reduction in frequency.

If one of the leds switches off, this indicates that the end of the frequency range has been reached and that no more adjustment is available in that direction. The OUTPUT POWER meter can be used to tune the plate circuit; maximum meter reading (maximum output power) corresponding to correct tuning.

- 8) The LOAD tuning procedure follows in a similar fashion: holding down the TUNING switch, adjust the LOAD control for maximum output power.

REPEAT STEPS 7 AND 8 SEVERAL TIMES TO OBTAIN THE OPTIMUM SETTINGS

- 9) Increase exciter power until an output power of 2000W is obtained and repeat steps 7 and 8.

- 10) With output power at 2000 W, make small adjustments, as above, to minimize grid and anode currents; if necessary, reduce exciter power to maintain 2000 W of output power.

8.2 Calibration of the Protection Board

Before calibrating the protection board, or IG and IA currents, remove the front panel which also supports the RF chamber.

Disconnect the antenna output cable, remove the coaxial cable from the input connector, undo the 8 screws holding the panel and remove the panel; take care not to disturb the high voltage cables and the multipolar service cable.

Lay the chamber carefully on a raised surface, opposite the unit to facilitate the following procedure.

The protection board has three trimmers for adjusting the following alarm thresholds: insufficient fan pressure, excess V.S.W.R. and excess grid current.

These alarm conditions are indicated by three leds (Alarms Fig.1).

Remove the metal cover of the protection box by undoing the 4 screws.

The alarm thresholds may be calibrated through the following procedure:

1) CALIBRATION OF FAN PRESSURE ALARM THRESHOLD (PRESS.).

- a) Switch the ST.BY. switch (19 Fig.1) to ST.BY.
- b) Enable power to the unit by switching the POWER switch (18 Fig.1) to ON.
- c) Ensure that the PRESS. indicator (15 Fig.1), initially on, turns off when the air-flow switch (3 Photo 2), positioned inside the flue, switches up (air pressure normal).

Two error conditions can prevent the above sequence from being completed: the indicator remains on, or remains permanently off.

In this case adjust the trimmer, R4, until the sequence is completed correctly: switch down, led on; switch up, led off.

2) CALIBRATION OF V.S.W.R.

To adjust the threshold of the V.S.W.R. alarm first perform SETUP 1.

The threshold should be set at around 10 % of the maximum output power i.e. between 170 and 200W.

- a) Connect a mismatched, dummy load (e.g. 2.0KW/50 Ohm in parallel) to the RF output of the amplifier, in series with a bypass wattmeter.
- b) With the unit switched on (N.B. the rear cover must be in place) and having calibrated the unit to its exciter frequency, gradually increase the output power from 0W until a reflected power of 170/200W is registered on the external wattmeter.
- c) Adjust the trimmer R7 until the alarm threshold is reached and the V.S.W.R. led lights up (13 Fig.1).

N.B. Several attempts may be necessary. At least 60 seconds should be allowed inbetween attempts to allow an automatic reset.

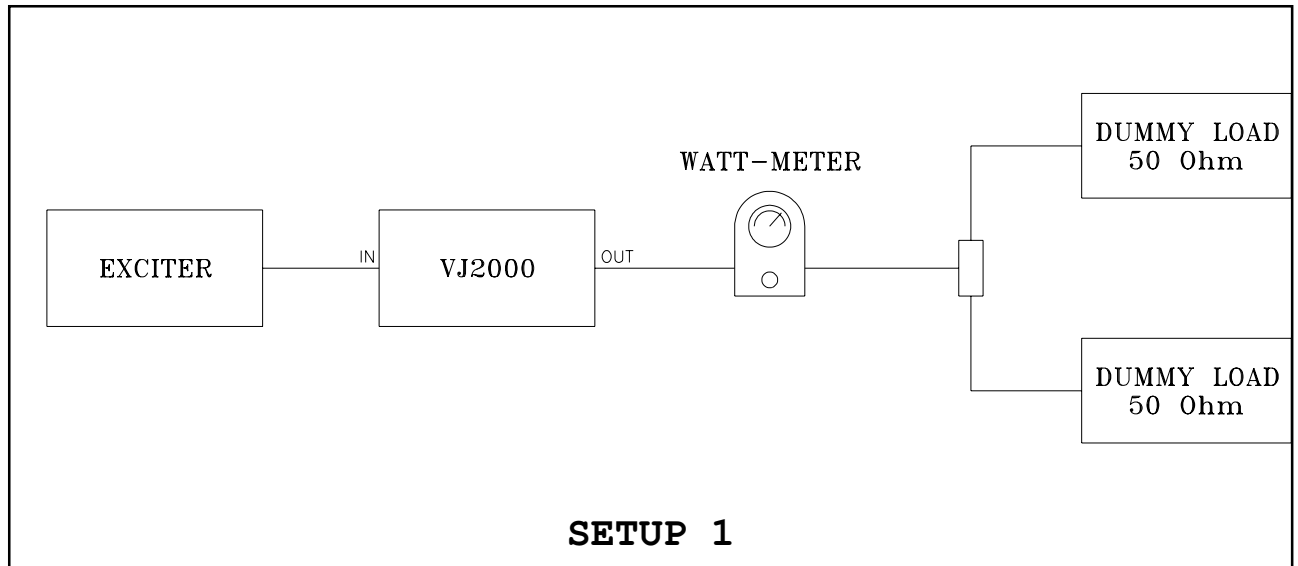

3) CALIBRATION OF THE GRID CURRENT (IG) ALARM THRESHOLD

- a) Connect the unit to the line supply and connect a dummy load (50Ohms $P > 2KW$, see SETUP 2).
- b) Switch the ST.BY. switch (19 Fig.1) to ST.BY.
- c) Wait for the fan to build up pressure.
- d) Perform the SETUP 3 (Pag.41) procedure and steps required to calibrate the grid current IG (paragraph 5.3).
- e) Adjust the reading (regulating the supply) to 60 mA.
- f) Adjust trimmer R21 until the IG protection is activated i.e. when the IG indicator (12 Fig.1) comes on.
- g) Reduce the indicated current to 40 mA.

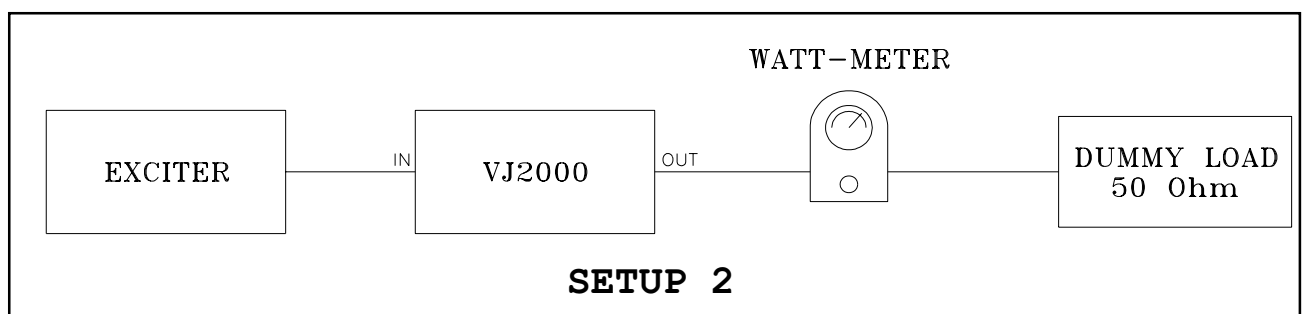

- h) Wait for the automatic protection cycle to complete and repeat step e) to verify the correct alarm threshold (60 mA).

8.3 Calibration of the Grid Current Meter (IG)

Perform SETUP 3.

- 1) Switch the IG-IA meter switch to the IG position (5 Fig.1).
- 2) The unit should be switched off.
- 3) Adjust the output voltage of the external power supply to 0V.
- 4) Connect the external power supply to the 2.2 Ohm, 5W resistor R4 situated on the rear of the meter (current).

The polarity should be such as to produce a clockwise deflection.

- 5) Increase the power supply voltage and check for a proportional increase in the grid current (as measured by the VJ2000 meter) and in the current supplied by the power supply.
- 6) Adjust trimmer R2 for a correct reading.

8.4 Calibration of Anode Current Measurement (IA)

Perform SETUP 4.

Perform the procedure detailed for the calibration of the grid current measurement, but instead connect the power supply to the R3 0.22 Ohm resistor found on the same board. Use R1 to calibrate the IA meter.

8.5 Calibration of Heater Voltage Measurement (HEATER)

- 1) The unit should must be switched off, perform SETUP 5.
- 2) Switch the Heater/Plate Voltage meter switch (7 Fig.1) to the Heater position.
- 3) Connect a dummy load (e.g. P>2KW/50 Ohm) to the RF Output of the amplifier.
- 4) Connect the External Multimeter on Pin 1-2 of JP2 connector of the Voltmeter Card (Heater Voltage meter card).
- 5) Before to switch on the External Multimeter verify that the multimeter selector is on VAC position.
- 6) Switch on the tube amplifier and with ST.BY selector (19 Fig.1) switch over ST.BY position.
- 7) Adjust R2 trimmer of the Voltmeter Card to obtain the same measurement both on the Voltage Measure Meter (6 Fig.1) placed on the front panel and on External Multimeter.

8.6 Calibration of Plate Voltage Measurement (PLATE)

WARNING : Pay attention during this adjustment because are present dangerous voltages; for this adjustment always use grounding

- 1) The unit should must be switched off, perform SETUP 6.
- 2) Switch the Heater/Plate Voltage meter switch (7 Fig.1) to the Plate position.
- 3) Connect a dummy load (e.g. $P > 2KW/50 \text{ Ohm}$) to the RF Output of the amplifier.
- 4) Before to switch on the External Multimeter verify that the multimeter selector is on VAC position.
- 5) Connect a multimeter equipped with probe for high tension measuring, to the common terminal between R3 and C2, and to E contact on the High Tension Card.
- 6) Switch on the tube amplifier.
- 7) Adjust R3 trimmer of the Plate voltage measure Card to obtain the same measurement both on the Voltage Measure Meter (6 Fig.1) placed on the front panel and on External Multimeter.

8.7 Calibration of the PWR Meter (FWD-PWR LECTURE)

Perform SETUP 7.

- 1) Connect a 50 Ohm 2KW dummy load in series with a bypass wattmeter (Byrd model 43), switch on the amplifier and verify the correct reading of the VJ2000's meter.
- 2) Adjust trimmer R9, situated inside the directional coupler on the output of the low-pass filter, near the antenna connector.
- 3) To gain access, remove the small protection cover.

N.B. The trimmer R2 connected in series with the meter allows small adjustments after the calibration of PWR, REF and FWD, and is normally in a central position.

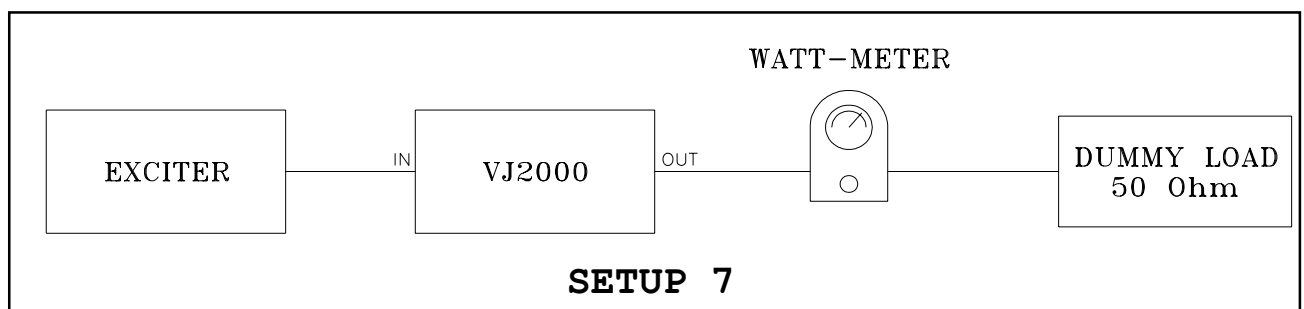

8.8 Calibration of the PWR Meter (REF-PWR LECTURE)

Perform the calibration procedure for the V.S.W.R. protection upto step b) (paragraph 5.2 (2)).

At this point verify that the VJ2000 meter reading is correct; adjustment may be made with trimer R6 situated in the directional coupler on the output of the low-pass filter, near the antenna connector.

To gain access to it, remove the small protection cover.

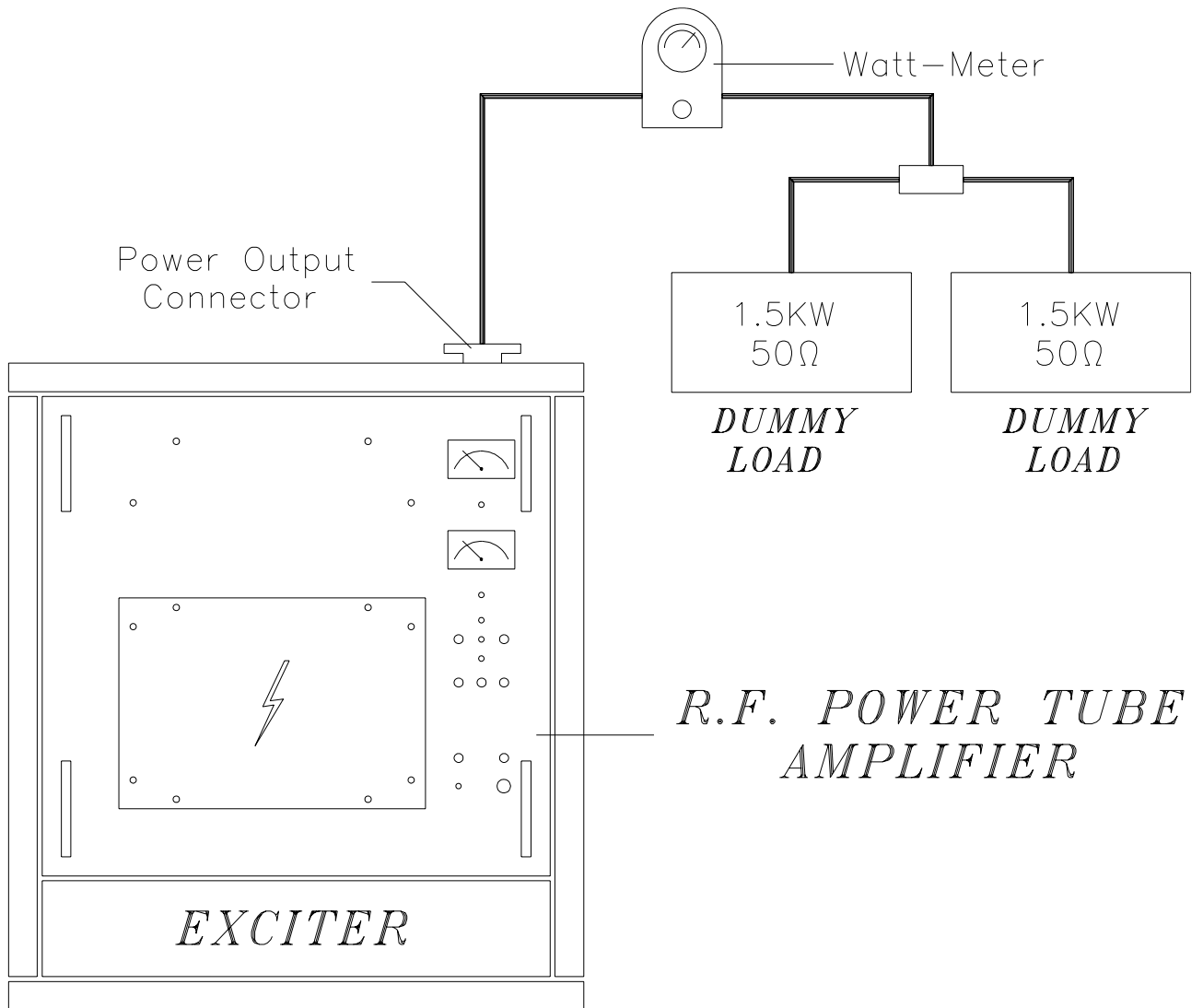

SETUP 3 / FIG. 3

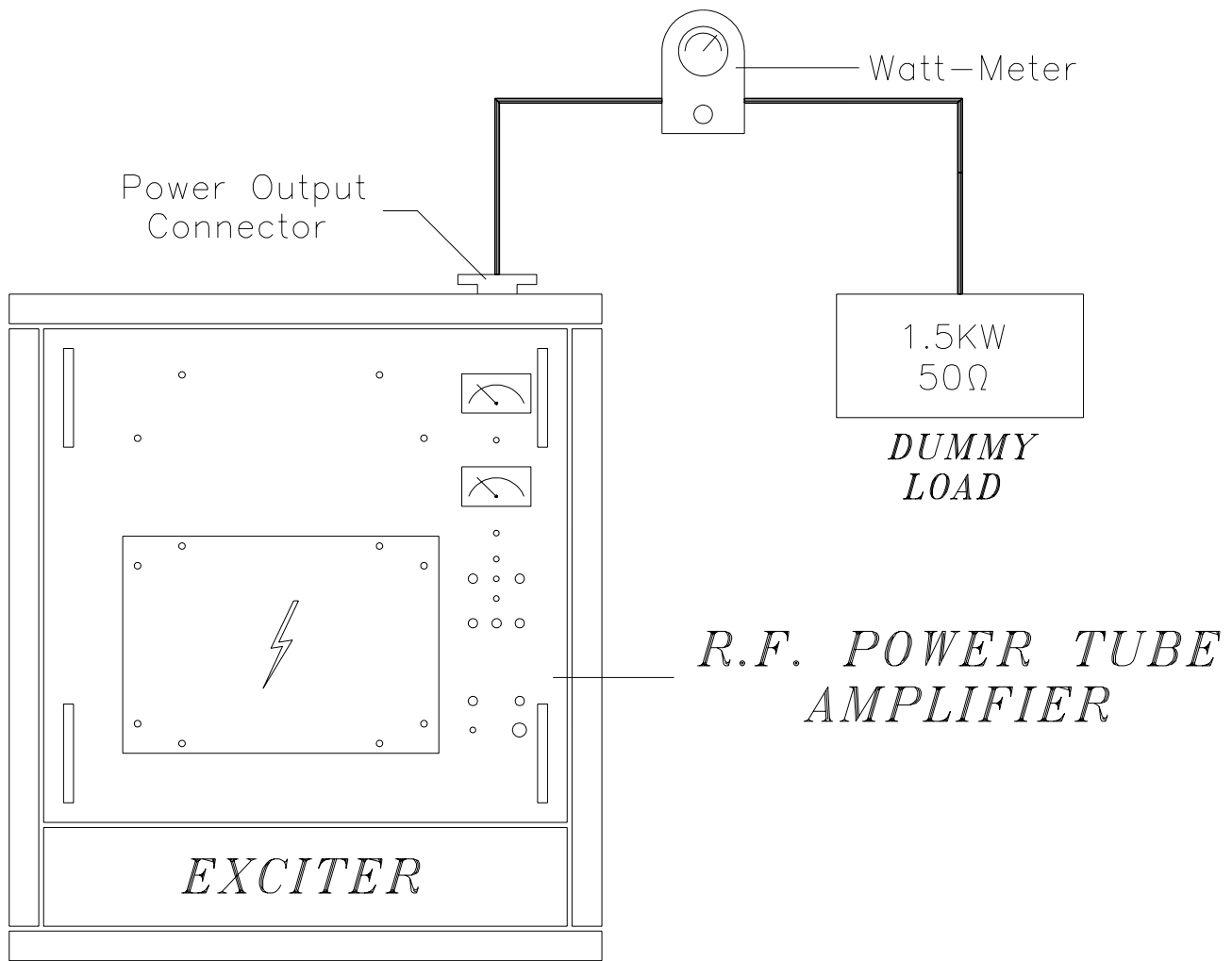

SETUP 4 / FIG. 4

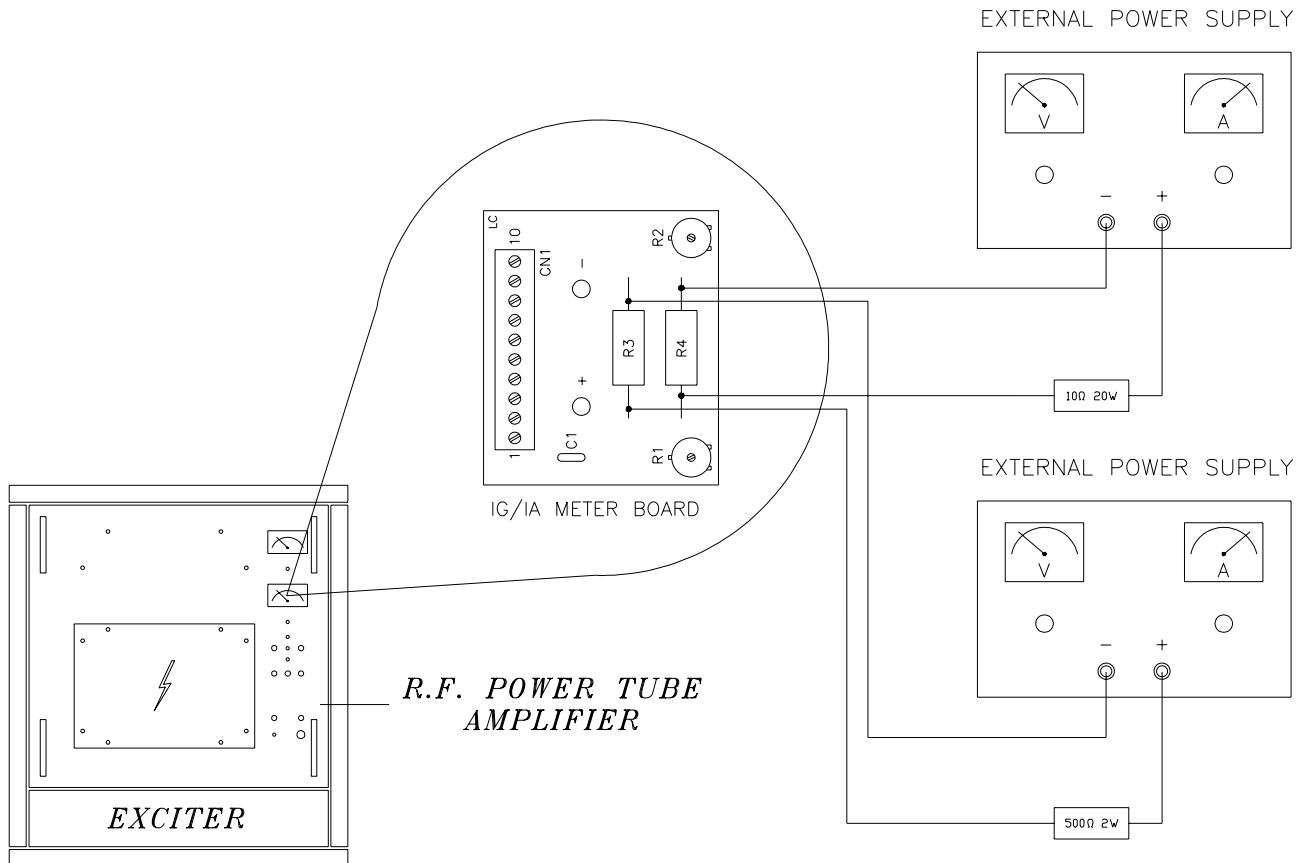

SETUP 5 / FIG. 5

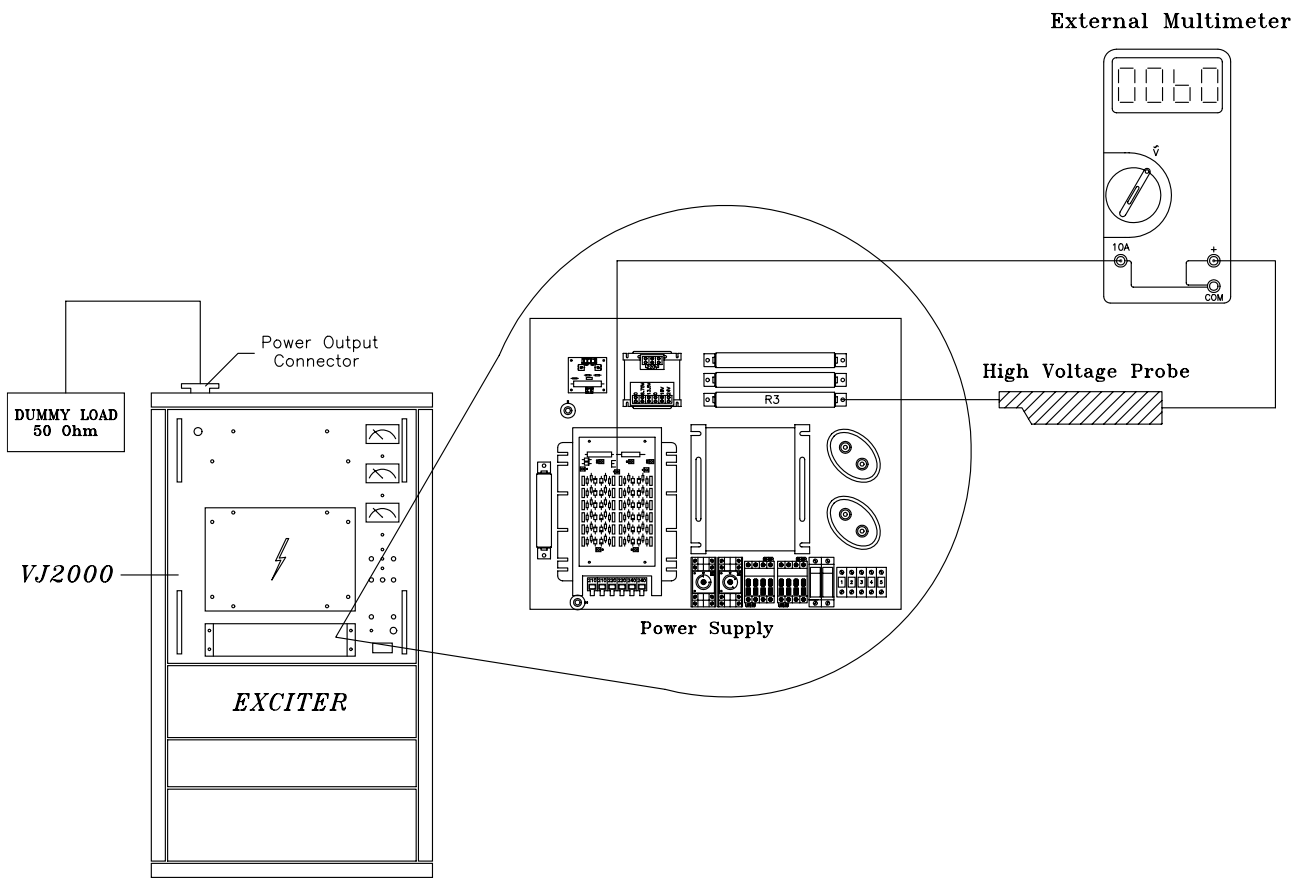

SETUP 6 / FIG. 6

9. Connectors Description

9.1 Telemetry Connector

Type: DB25 Female

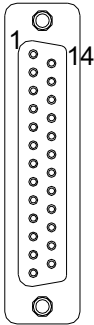

1	Anodic Voltage Output (ONLY VJ2000)	3V X 4000V
2	Anodic Current Measurement Output	5V X 1A
3	GND	0V
4	Reflected Power Measurement Output	1.4V X 100W
5	Not Used	
6	Not Used	
7	Not Used	
8	Input Command ON (High Voltage)	
9	Not Used	
10	Not Used	
11	Not Used	
12	Not Used	
13	Not Used	
14	Not Used	
15	Not Used	
16	Forward Power Measurement Output	1.6V X 1000W
17	Antenna Alarm SWR (This Signal come directly from the Alarms Card)	12V when fault
18	Grid Current Measurement Output	5V X 100mA
19	Not Used	
20	Input ON	
21	Not Used	
22	Not Used	
23	Not Used	
24	Not Used	
25	Not Used	

10. Telemetry Card Option

10.1 Calibration of the Voltages on the Telemetry connector

The VJ's internal Telemetry connector gives to the external the voltages referred to the various values under control. The voltage related to the Forward Power output is 1,6V for 1KW. To calibrate this voltage follow the procedure below:

- 1- Adjust the power of the machine to the nominal value of 1KW.
- 2- Adjust R13 on the Telemetry Card to obtain a voltage, between pin 16 and pin 1 of Telemetry connector, of 1,6V.

The pin 4 gives the voltage referred to measurement of the Reflected Power. This voltage is 1,4V for 100W (10% of 1KW). To calibrate this voltage follow the procedure below:

- 1- Adjust the Reflected Power to 100W using a wattmeter Bird in output.
- 2- Adjust R14 of Telemetry Card to obtain a voltage, between pin 14 and pin 1 of connector, of 1,4V.
- 3- Adjust R36 to set the Power Good threshold.

10.2 Wiring Connections details

- 1- The exciter is not supplied from the Service Connector but separately. This is because if there was no high voltage, the Service Connector would be not supplies instead, too. The exciter shall be ever ON.
- 2- A system that closes to earth a BNC contact when the machine is in Standby mode is used. This contact is connected with a BNC-BNC cable to the Interlock/ RF Mute connector of the exciter. When the VJ goes in Standby status, the exciter enters in RF Mute mode. The contact that permits this functionality is located on the Service teleswitch.
- 3- A Reset (or Restart) button is connected between pin 9 and earth of Telemetry Card JP2 connector and it's located on the front panel. It's used to give the same kind of signal as the an exciter that an PTXLCD gives when it is switches ON. This operation resets the alarms and the remote control relay, in case the amplifier is in OFF status and there is not an exciter able to change it to the ON status.
- 4- The Alarms Card is supplied by the alternate current that first passes throught JP3 (pin 1 and 2) of telemetry. When the Telemetry Card receives the REMOTE OFF command, Alarms Card turns OFF itself. This permits to remotely reset the alarms throught an ON-OFF-ON sequency. Please remember that after 6 attempts failed the machine will block itself. This remote control system gives a remote reactivation mechanism.
- 5- A green LED is mounted between the point S of the Alarm Card and ground (throught a 2K2 resistor); this is to indicate whether the Alarms Cards is supplied or not.

- 6- The DB25/telemetry connector cable is connected as shown in the diagrams in appendix.
- 7- The system is the same for VJ1000 and VJ2000.

10.3 General Verifications

- When Standby mode and operating the related switch, the exciter shall go in RF Mute mode.
- VJ1000/2000 shall switch to Standby mode if the exciter put in the OFF status.
- If the VJ has completed a reset cycle for 6 times and it's thus blocked, a series of ON-OFF-ON of the exciter shall reset the alarms.
- Only the SWR ANT Alarm is telecontrolled.

Appendix

Piani di montaggio, schemi elettrici, liste componenti / *Component layouts, schematics, bills of material*

Questa parte del manuale contiene i dettagli tecnici riguardanti la costruzione delle singole schede componenti il VJ2000. L'appendice è composta dalle seguenti sezioni:

This part of the manual contains the technical details about the different boards of the VJ2000. This appendix is composed of the following sections:

Description	RVR Code	Vers.	Pages
Flat Cable Telemetry Connector		1.0	2
Telemetry Cable		1.1	2
Power Supply (single phase version)		1.0	6
H.T. Rectifier Card (single phase version)		1.0	4
R.F. Block (single phase version)		1.0	4
Power Supply (three phase version)		1.0	4
H.T. Rectifier Card (three phase version)		1.0	2
R.F. Block (three phase version)		1.0	4
Alarms Card		1.0	4
Grid/Plate Current Meter Board		1.0	4
Heater Voltage Measure and Voltmeter Card		1.0	4
Plate Voltage Measure Card		1.0	4
Low Pass Filter		1.0	4
Input Matching Circuit		1.0	4
Directional Coupler		1.0	4
Telemetry Card (optional)		1.0	4

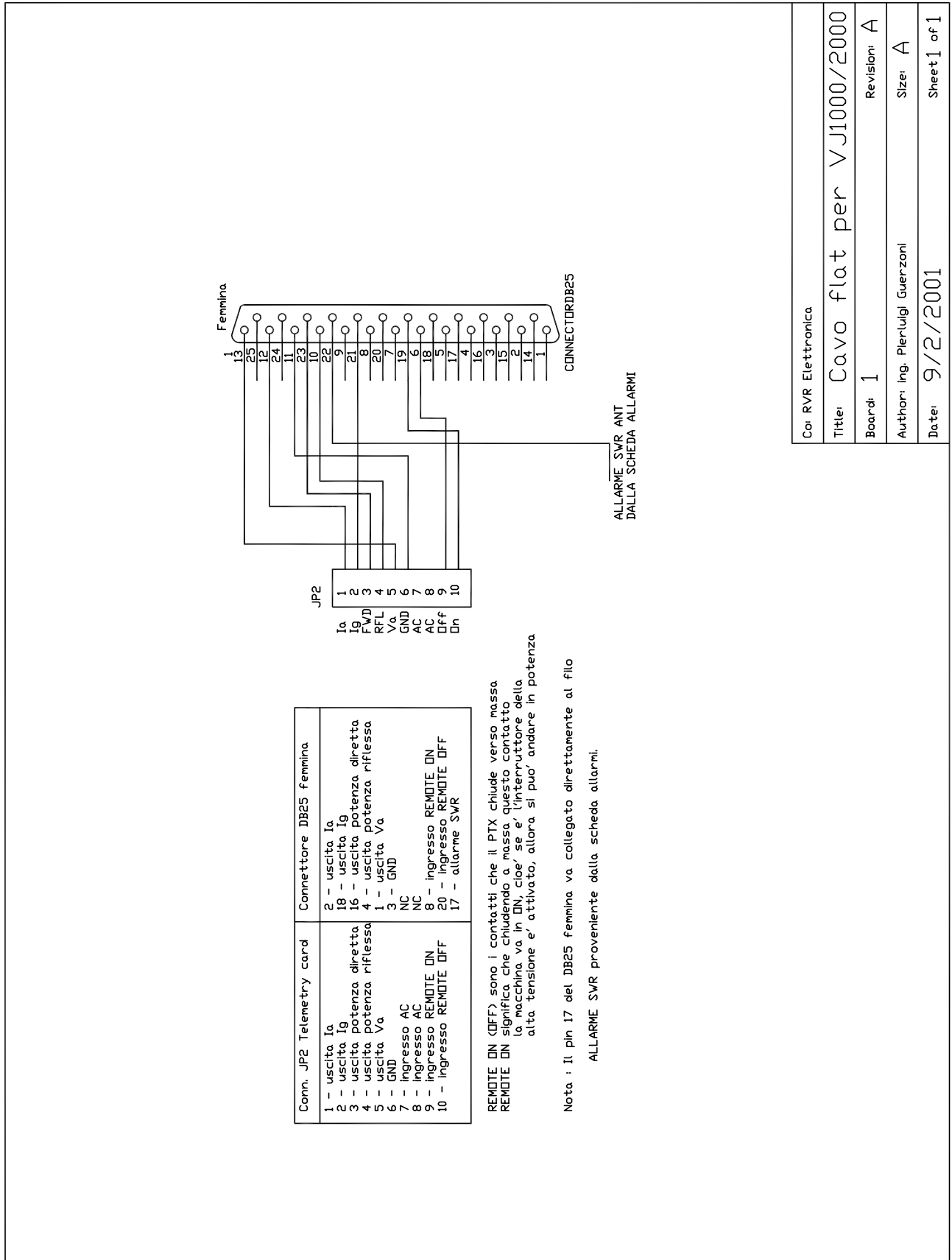

Co: RVR Elettronica	
Title: Cavo flat per VJ1000/2000	Revision: A
Board: 1	Size: A
Author: Ing. Pierluigi Guerzoni	Date: 9/2/2001
	Sheet 1 of 1

Pagina lasciata intenzionalmente in bianco
This page was intentionally left blank

Cavo Telemetria per VJ1000/2000 --- PTXLCD

Nel menu' ExSts del PTX LCD si ha:
 V1 : VA (3 V per 4000 V SUDO VJ2000)
 V2 : IA (5 V per 1 A)
 V3 : IG (5 V per 100mA)
 V4 : Allarme SWR ANT (4,8V when Fault)
 V5 : NON USATO
 V6 : NON USATO

Nel menu' ExpWR del PTX LCD si ha
 Misura della potenza diretta del finale espressa in %
 Misura della potenza riflessa del finale espressa in %
 < queste misure vanno agglustate con i trimmer posti sul retro >

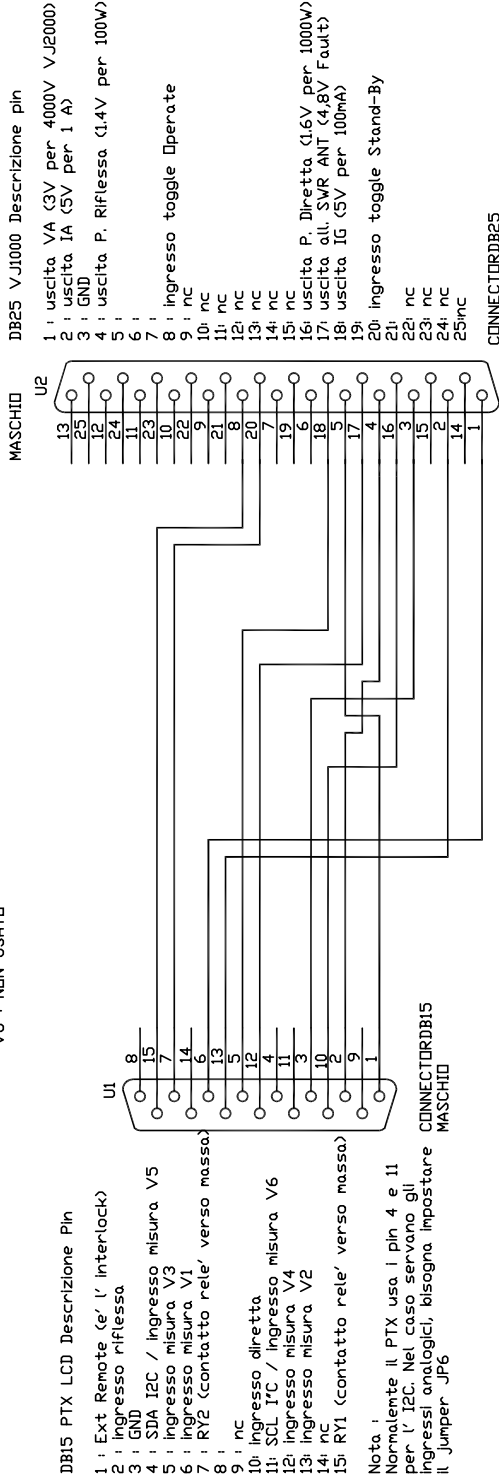

- DB15 PTX LCD Descrizione Pin**
- 1 : Ext Remote (e' l' interlock)
 - 2 : Ingresso riflessa
 - 3 : GND
 - 4 : SDA I2C / ingresso misura V5
 - 5 : ingresso misura V3
 - 6 : ingresso misura V1
 - 7 : RY2 (contatto rele' verso massa)
 - 8 :
 - 9 : nc
 - 10: ingresso diretta
 - 11: SCL I2C / ingresso misura V6
 - 12: ingresso misura V4
 - 13: ingresso misura V2
 - 14: nc
 - 15: RY1 (contatto rele' verso massa)

Nota :
 Normale il PTX usa i pin 4 e 11 per l' I2C. Nel caso servano gli ingressi analogici, bisogna impostare il Jumper JP6

Tabella. Corrispondenze

DB15 Maschio (PTX)	DB25 Maschio (VJ-1000)
1 ExtRemote	5 NON USATO NEL VJ1000
2 Ingresso riflessa	4 uscita potenza riflessa (1.4V per 100W)
3 calza	3 calza
5 in An3 (V3)	18 uscita IG (5V per 100mA)
6 in An1 (V1)	20 Ingresso Stand By : il PTX invia un segnale toggle per mettere in standby il finale
7 RY2	16 uscita potenza diretta (1.6 V per 100W)
10 Ingresso diretta	17 Allarme SWR ANT (3,8V when Fault)
12 in An4 (V4)	2 uscita IA (5V per 1A)
13 in An2 (V2)	8 uscita Operate : il PTX invia un segnale toggle per mettere ON il finale
15 RY1	

Nota:
 Nel VJ1000 non viene fornita la Va. Il cavo lo prevede per i modelli superiori al VJ1000.

Nota:
 Questo cavo e' identico a quello per il PJ300, ma cambia il significato dei singoli conduttori

Co: RVR Elettronica	
Title: Cavo Telemetria VJ1000/2000	Revision: A
Board: 1	Size: A
Author: Ing. Pierluigi Guerzoni	Date: 21/11/2000
Sheet 1 of 1	

Pagina lasciata intenzionalmente in bianco
This page was intentionally left blank

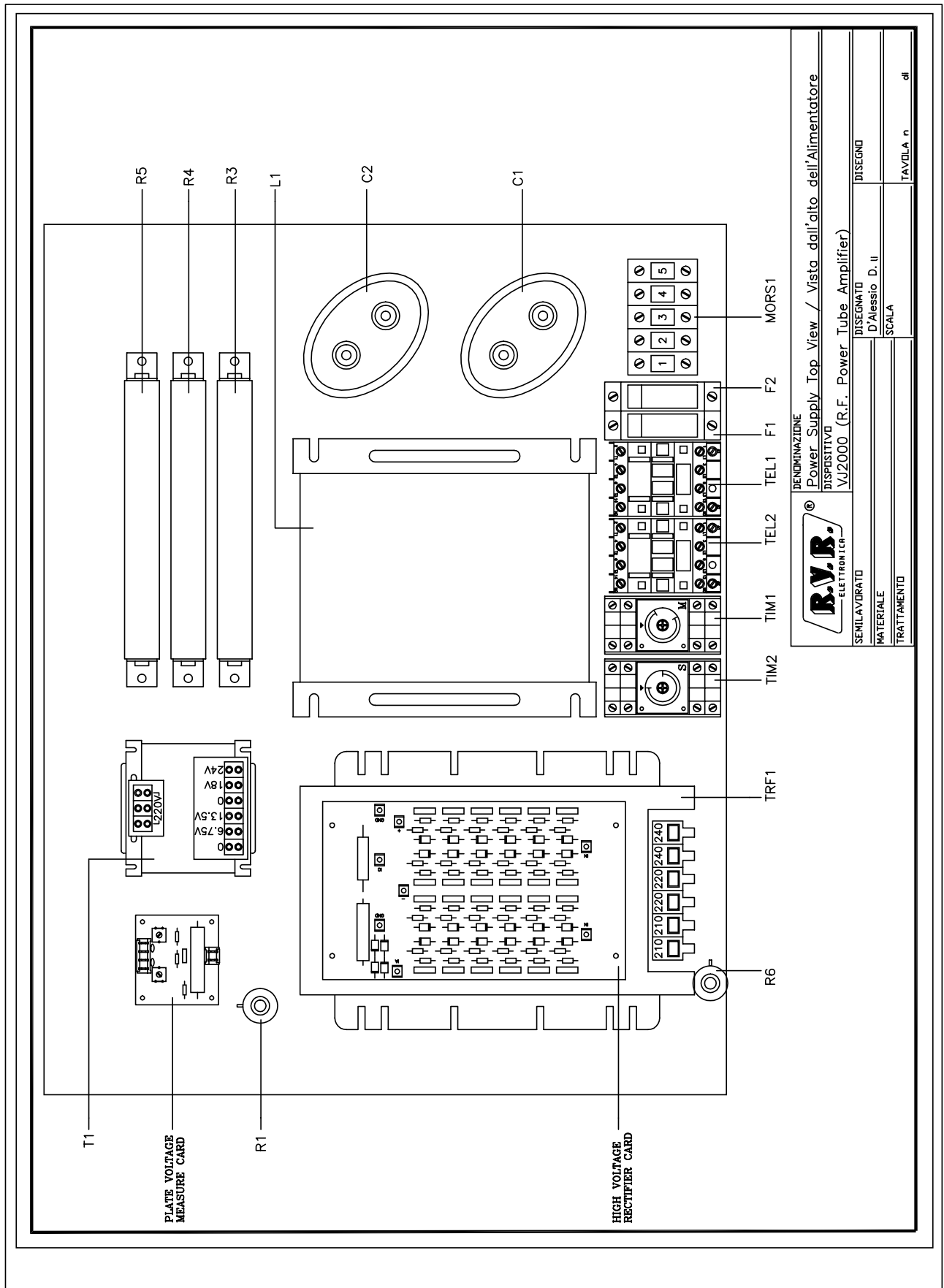

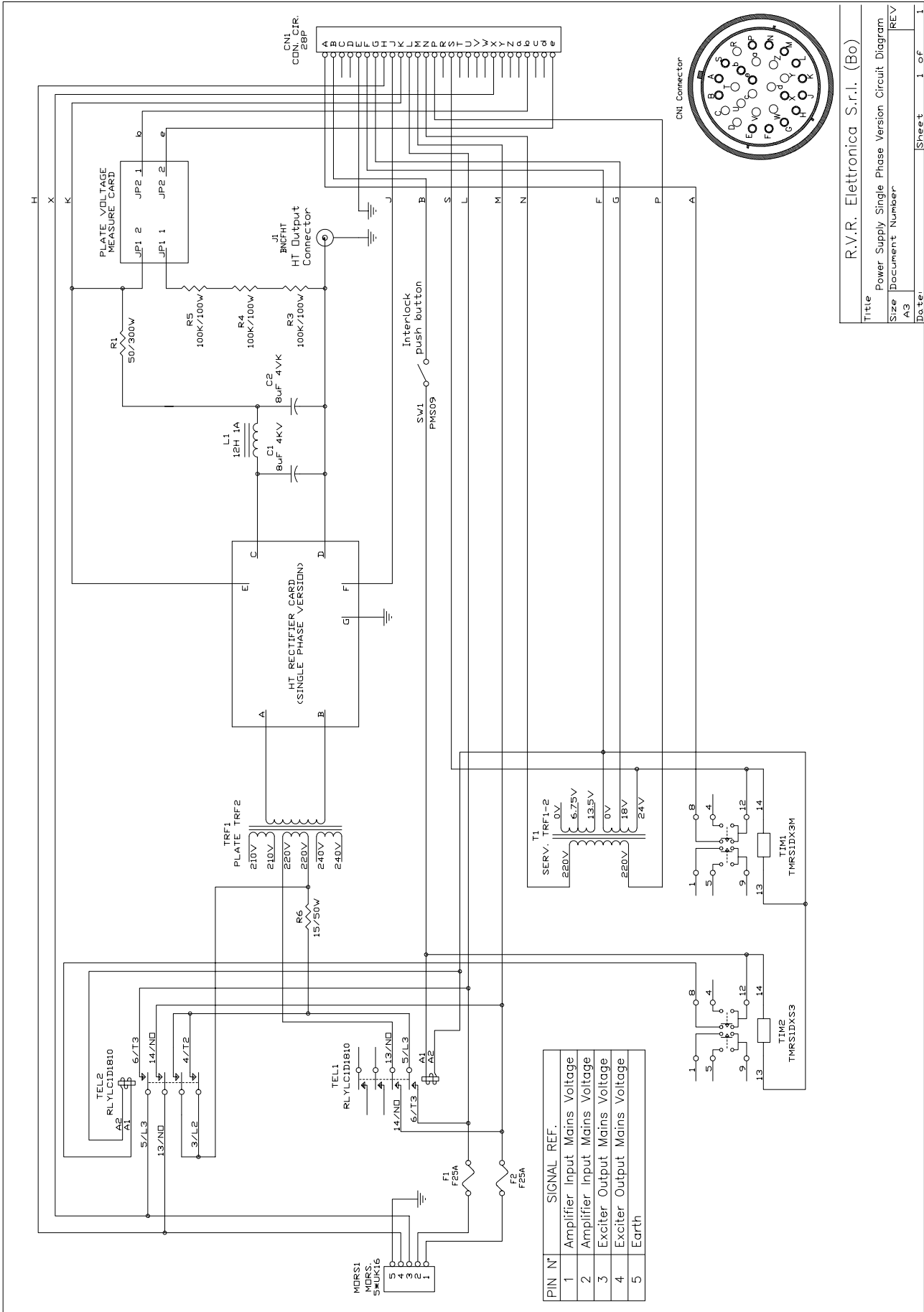

R.V.R. Elettronica S.r.l. (Bo)

Title Power Supply Single Phase Version Circuit Diagram
 Size A3
 Document Number REV
 Date: Sheet 1 of 1

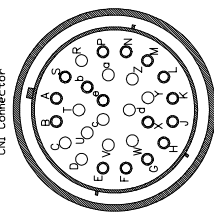

Item	Quantity	Reference	Part	Description	Part Order Code
1	1	R6	15/50W	RESISTOR 50W	RAF050HH0015
2	1	R1	50/300W	RESISTOR 300W	RAF300JH0050
3	3	R3,R4,R5	100K/100W	RESISTOR 100W	RAF100JK0100
4	2	C1,C2	8µF 4KV	HIGH VOLTAGE CAPACITOR	COL4000V0008
5	1	L1	12H 1A	CHOKE FILTER	IMP012H1A
6	2	F1,F2	F25A	FAST FUSIBLE	FUS10.3X3825
7	1	CN1	CON. CIR. 28PF	CON. CIR. 28P BURNDY F.	CNTBLCCF28P
8	1	MORS1	MORS.5*UK16	MORS. 5*UK16 PHOENIX	MORS5*UK16
9	1	J1	BNCFHT	CONN. BNC FEM. PER HT	CNTBNCFHT
10	2	TEL1,TEL2	RLYLC1D1810	TEL. TELEMEC. LC1D18-10	TLRLC1D1810
11	1	TIM1	TMRS1DX3M	TIM. MATSH. 24AC 2C 3M	TMRS1DX2C3M
13	1	TIM2	TMRS1DX3S	TIM. MATSH. 24AC 2C 3S	TMRS1DX2C3S
13	1	SW1	PMS09	PULS. 1V MS09 PIZZATO	PLS1VMS09
14	1	TRF1	PLATE TRF2	TRANSFORMER PRIM. : 210/220/240V SEC. : 3150V 4KW	TRFPLTVJ2000
15	1	T1	SERV.TRF1-2	TRFANSFORMER PRIM. : 220V SEC. : 6.75-0-6.75 0/18/24	TRFSERVJ2000

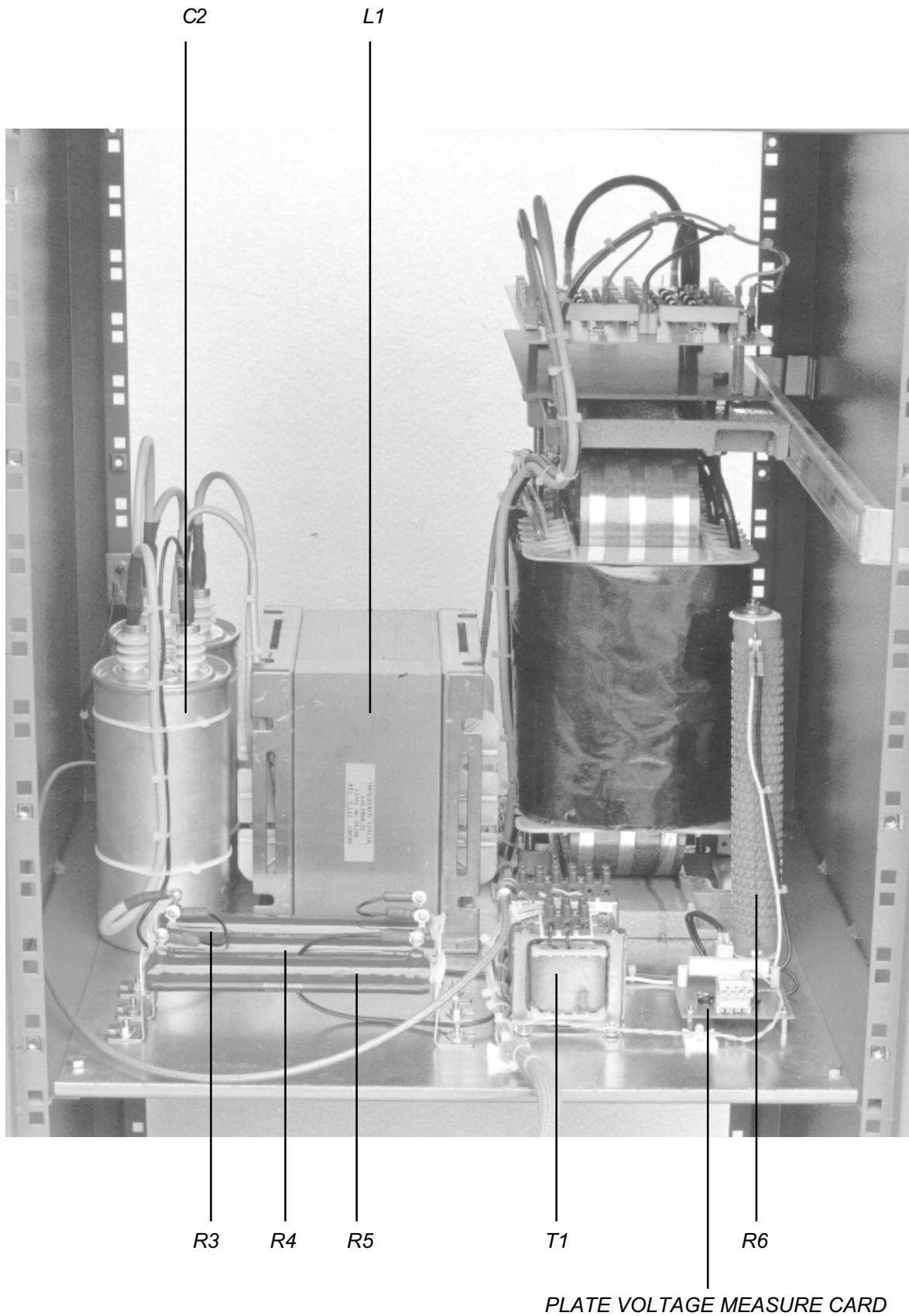

POWER SUPPLY (SINGLE PHASE VERSION) FRONT VIEW

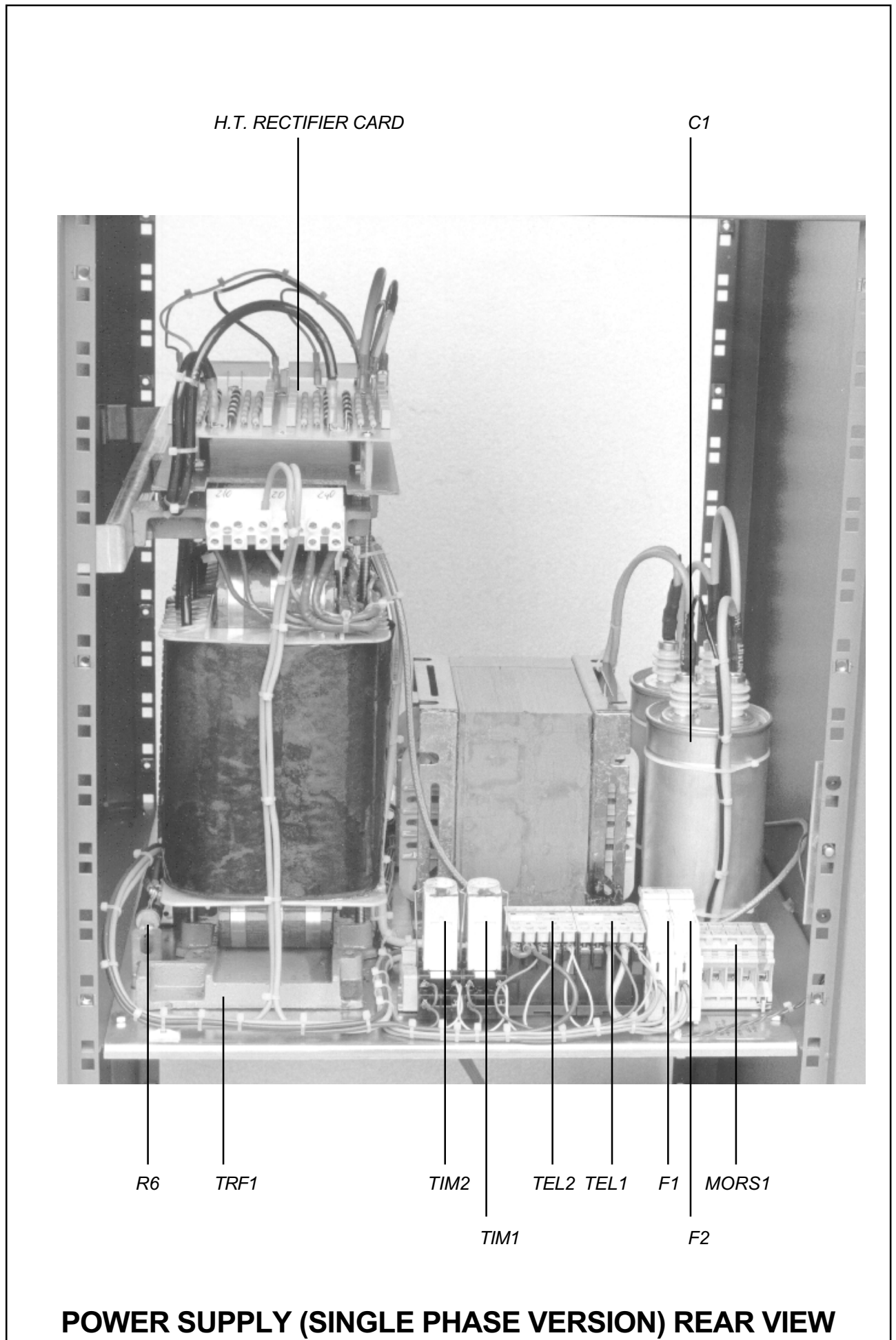

Pagina lasciata intenzionalmente in bianco
This page was intentionally left blank

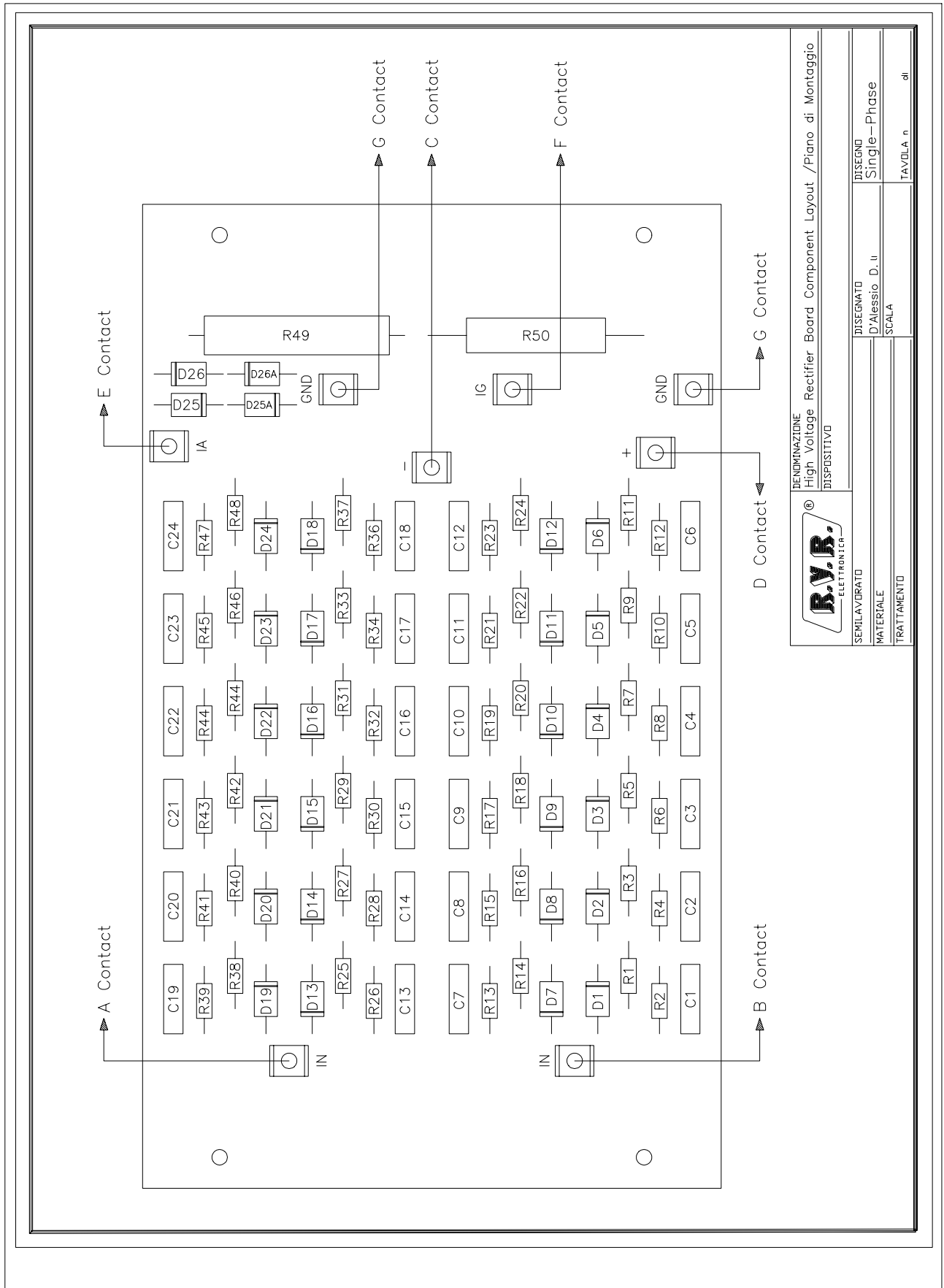

		DENOMINAZIONE High Voltage Rectifier Board Component Layout /Piano di Montaggio DISPOSITIVO	
SEMILA/DRATO		DISEGNATO D'Alessio D. II	DISEGNO Single-Phase
MATERIALE		SCALA	TAVOLA n. di
TRATTAMENTO			

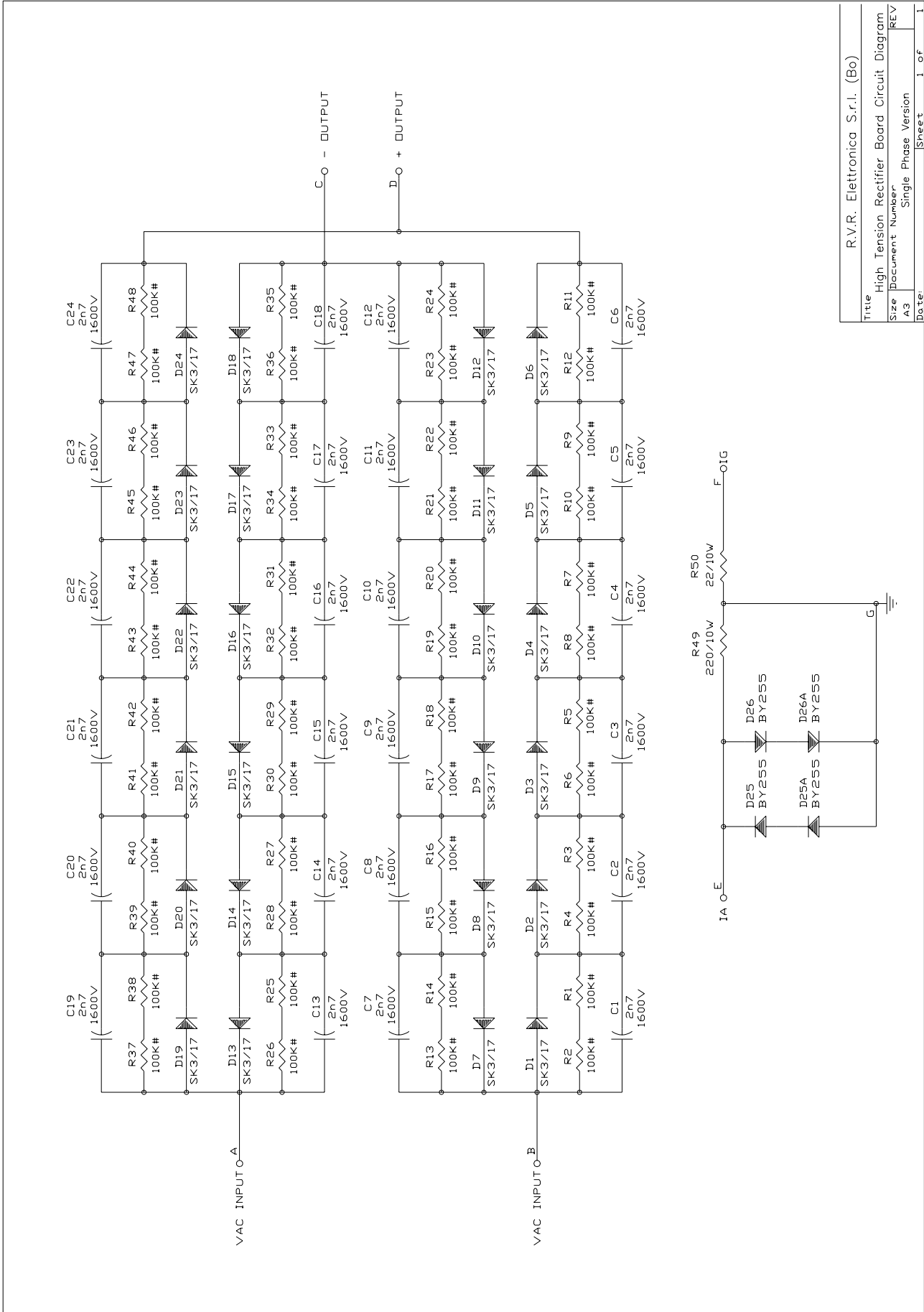

Title		R.V.R. Elettronica S.r.l. (Bo)
Description		High Tension Rectifier Board Circuit Diagram
Size	Document Number	REV
A3	Single Phase Version	
Date:	Sheet	1 of 1

<i>Item</i>	<i>Quantity</i>	<i>Reference</i>	<i>Part</i>	<i>Description</i>	<i>Part Order Code</i>
1	1	R50	22/10W	RESISTOR 10W	RAF010KH0022
2	1	R49	220/10W	RESISTOR 10W	RAF010KH0220
3	48	R1,R2,R3, R4,R5,R6, R7,R8,R9, R10,R11,R12, R13,R14,R15, R16,R17,R18, R19,R20,R21, R22,R23,R24, R25,R26,R27, R28,R29,R30, R31,R32,R33, R34,R35,R36, R37,R38,R39, R39,R40,R41, R42,R43,R44, R45,R46,R47, R48	100K#	RESISTOR 2W	RSC002JH0100
4	24	C1,C2,C3, C4,C5,C6, C7,C8,C9, C10,C11,C12, C13,C14,C15, C16,C17,C18, C19,C20,C21, C22,C23,C24	2N7	CERAMIC CAPACITOR	CKM272BK600P
5	24	D1,D2,D3, D4,D5,D6, D7,D8,D9, D10,D11,D12, D13,D14,D15, D16,D17,D18, D19,D20,D21, D22,D23,D24,	SK3/17	SEMICRON DIODE 3A 1700V	DISSK3/17
6	4	D25,D25A, D26,D26A	BY255	SILICON DIODE 3A 1000V	DISBY255

Pagina lasciata intenzionalmente in bianco
This page was intentionally left blank

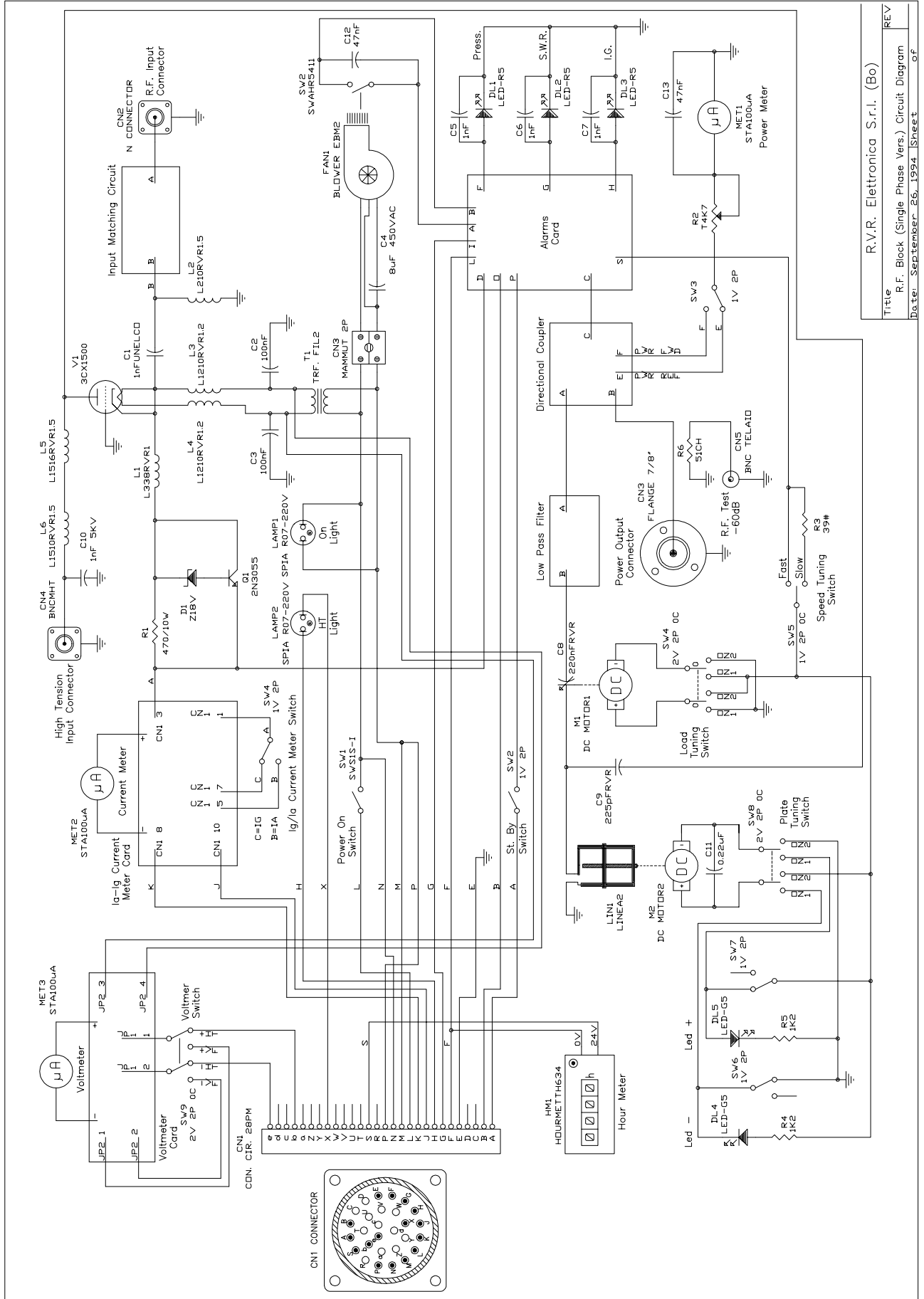

R.V.R. Elettronica S.r.l. (Bo)	
Title	R.F. Block (Single Phase Vers.) Circuit Diagram
Date:	September 26, 1994
Sheet	of
REV	

Item	Quantity	Reference	Part	Description	Part Order Code
1	1	R3	39#	RESISTOR 2W	RSC002JH0039
2	1	R6	51CH	CHIP RESISTOR	RCC1/4JH0051
3	1	R1	470/10W	RESISTOR 10W	RAF010KH0470
4	2	R4,R5	1K2	RESISTOR 1/4W 5%	RSC1/4JK01,2
5	1	R2	T4K7	TRIMMER REG. VERT. 10mm	RVTD10VK04,7
6	1	C9	225pFRVR	CERAMIC CAP. RVR	CKM225BRVR
7	3	C5,C6,C7	1nF	CERAMIC CAPACITOR	CKM102BK600P
8	1	C1	1nFUNELCO	SILVER MICA CAPACITOR	CSM102XK351
9	1	C10	1nF 5KV	HT CERAMIC CAPACITOR	CHT102B5000V
10	2	C12,C13	47nF	CERAMIC CAPACITOR	CKM473BK600P
11	2	C2,C3	100nF	CERAMIC CAPACITOR	CKM104BK600P
12	1	C8	220nFRVR	CERAMIC CAP. RVR	CKM224BRVR
13	1	C11	0.22µF	POLIESTER CAPACITOR	CPE224DK101
14	1	C4	8µF 450VAC	HIGH VOLTAFE CAPACITOR	CHV0400V0008
15	2	L3,L4	L1210RVR1.2	12SP D.10 RAME S. 1.2mm	BFS12001210
16	1	L5	L1516RVR1.5	15SP D.16 RAME S. 1.5mm	BFS15001516
17	1	L6	L1510RVR1.5	15SP D.10 RAME S.1.5mm	BFS15001510
18	1	L2	L210RVR1.5	2 SP D.10 RAME A. 1.5mm	BFS15000210
19	1	L1	L338RVR1	33SP D. 8 RAME S. 1mm	BFS10003308
20	3	MET1,MET2, MET3	STA100UA	STRUMENTO 100µA	SMABM55RQ101
21	1	HM1	HOURMETH634	H.M. MATSH. TH634 24V	SHMTH634
22	1	CN3	MAMMUT 2P	MORS. MP MONT. DIRET.2P	MORMP2P
23	1	CN1	C.CIR.28PM	CON. CIRC. 28P BULGIN M	CNTBLCCM28P
24	1	CN5	BNC TELAIO	CONN. BNC A TELAIO	CNTBNCFPV
25	1	CN4	BNCMHT	CONN. BNC MAS. PER HT	CNTBNCMHT
26	1	CN2	N CONNECTOR	CONN. N A TELAIO	CNTNFPFL
27	1	CN3	FLANGE 7/8"	FLANGE 7/8"	CNTFL7/8
28	5	SW2,SW3, SW4,SW6,SW7	1V 2P	DEVIATORE 1 VIA 2 POS	DEV1V1103CS
29	1	SW5	1V 2P 0C	DEV. 1 VIA 2 POS 0 CENT	DEV2V1M01M03
30	3	SW4,SW8,SW9	2V 2P 0C	DEV. 2 VIE 2 POS 0 CENT	DEV2V1M01M03
31	1	SW1	SWS1S-I	DEV. FEME 250VAC 15A	DEVSWS1S-I
32	1	SW2	SWAHR5411	MICROINT. NAT. AHR5411	DEVAHR5411
33	2	LAMP1,LAMP2	SPIA R07-220V	SPIA AL NEON 220V ROSSA	SPIA07RO220
34	3	DL1,DL2,DL3	LED-R5	RED LED DIODE	LEDRO05

35	2	DL4,DL5	LED-G5	GREEN LED DIODE	LEDVE05
36	1	D1	Z18V	ZENER DIODE 18V 0.4W	DIZ18V0W4
37	1	LIN1	LINEA2	LINEA VJ2000	LINVJ2000
38	1	M1	DC MOTOR1	MOT BUH. 1.61.013.325-W	MOTRCVJ200
39	1	M2	DC MOTOR2	MOT BUH. 1.61.013.330-0	MOTRPVJ200
40	1	Q1	2N3055	NPN SILICON TRANSISTOR	TRN2N3055
41	1	T1	TRF. FIL2	TRF. 220/5V 60VA	TRFFILVJ2000
42	1	FAN1	BLOWER EBM2	VENT. EBM G2E180AA0301	VTLEBMG2E180
43	1	V1	3CX1500	VALV. 3CX1500 EIMAC TR.	VAL3CX1500

Pagina lasciata intenzionalmente in bianco
This page was intentionally left blank

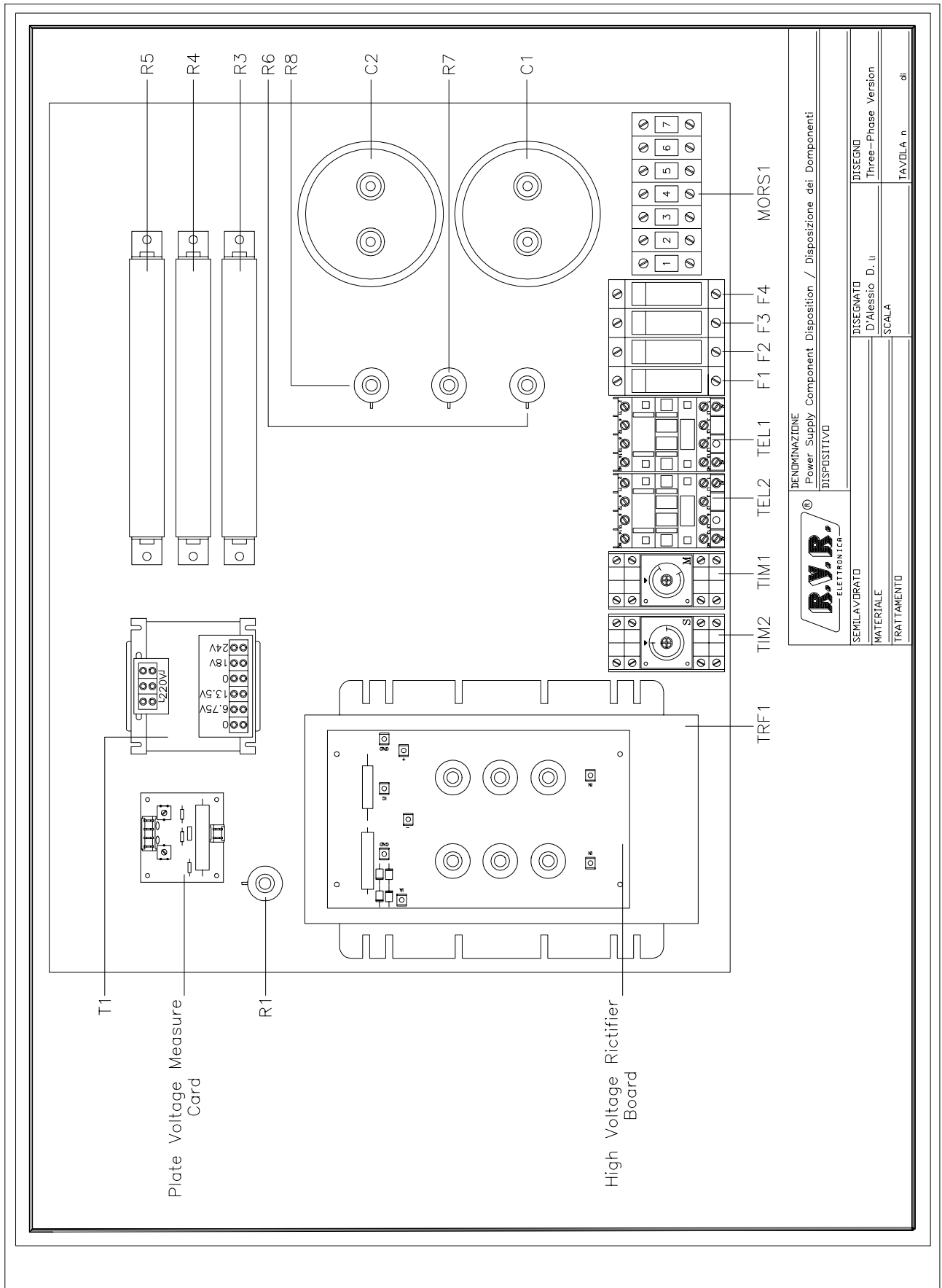

DENOMINAZIONE Power Supply Component Disposition / Disposizione dei Componenti DISPOSITIVO	
SEMILAVORATO	DISSEGNO
MATERIALE	D'Alessio D. U.
TRATTAMENTO	SCALA
	Three-Phase Version
	TAVOLA n. di

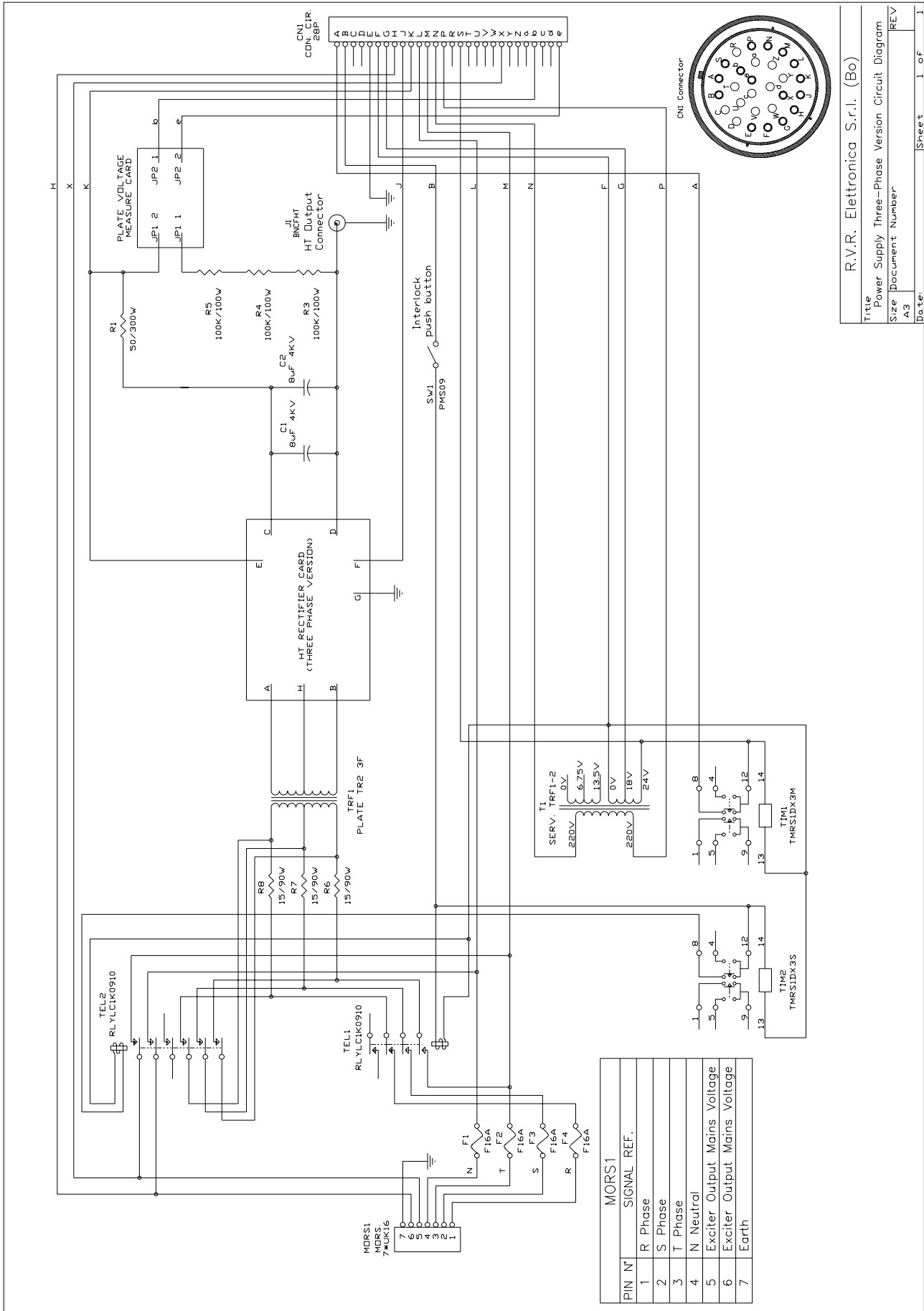

R.V.R. Elettronica S.r.l. (Bo)

Title: Power Supply Three-Phase Version Circuit Diagram

Size: A3

Document Number: REV

Date: Sheet 1 of 1

Item	Quantity	Reference	Part	Description	Part Order Code
1	3	R6,R7,R8	15/90W	RESISTOR 90W	RAF090HH0015
2	1	R1	50/300W	RESISTOR 300W	RAF300JH0050
3	3	R3,R4,R5	100K/100W	RESISTOR 100W	RAF100JK0100
4	2	C1,C2	8µF 4KV	HIGH VOLTAGE CAPACITOR	COL4000V0008
5	4	F1,F2,F3,F4	F16A	FAST FUSIBLE	FUS10.3X3816
6	1	CN1	CON. CIR. 28PF	CON. CIR. 28P BURNDY F.	CNTBLCCF28P
7	1	MORS1	MORS.5*UK16	MORS. 5*UK16 PHOENIX	MORS5*UK16
8	1	J1	BNCFHT	CONN. BNC FEM. PER HT	CNTBNCFHT
9	2	TEL1,TEL2	RLYLC1D1810	TEL. TELEMEC. LC1K0910	TLRLC1D1810
10	1	TIM1	TMRS1DX3M	TIM. MATSH. 24AC 2C 3M	TMRS1DX2C3M
11	1	TIM2	TMRS1DX3S	TIM. MATSH. 24AC 2C 3S	TMRS1DX2C3S
12	1	SW1	PMS09	PULS. 1V MS09 PIZZATO	PLS1VMS09
13	1	TRF1	PLATETR2 3F	THREE-PHASE TRANSFORMER PRIM. : 380V SEC. : 0-3300V 4KW	TRFPLT3FVJ2K
14	1	T1	SERV.TRF1-2	TRFANSFORMER PRIM. : 220V SEC. : 6.75-0-6.75 0/18/24	TRFSERVJ2000

Pagina lasciata intenzionalmente in bianco
This page was intentionally left blank

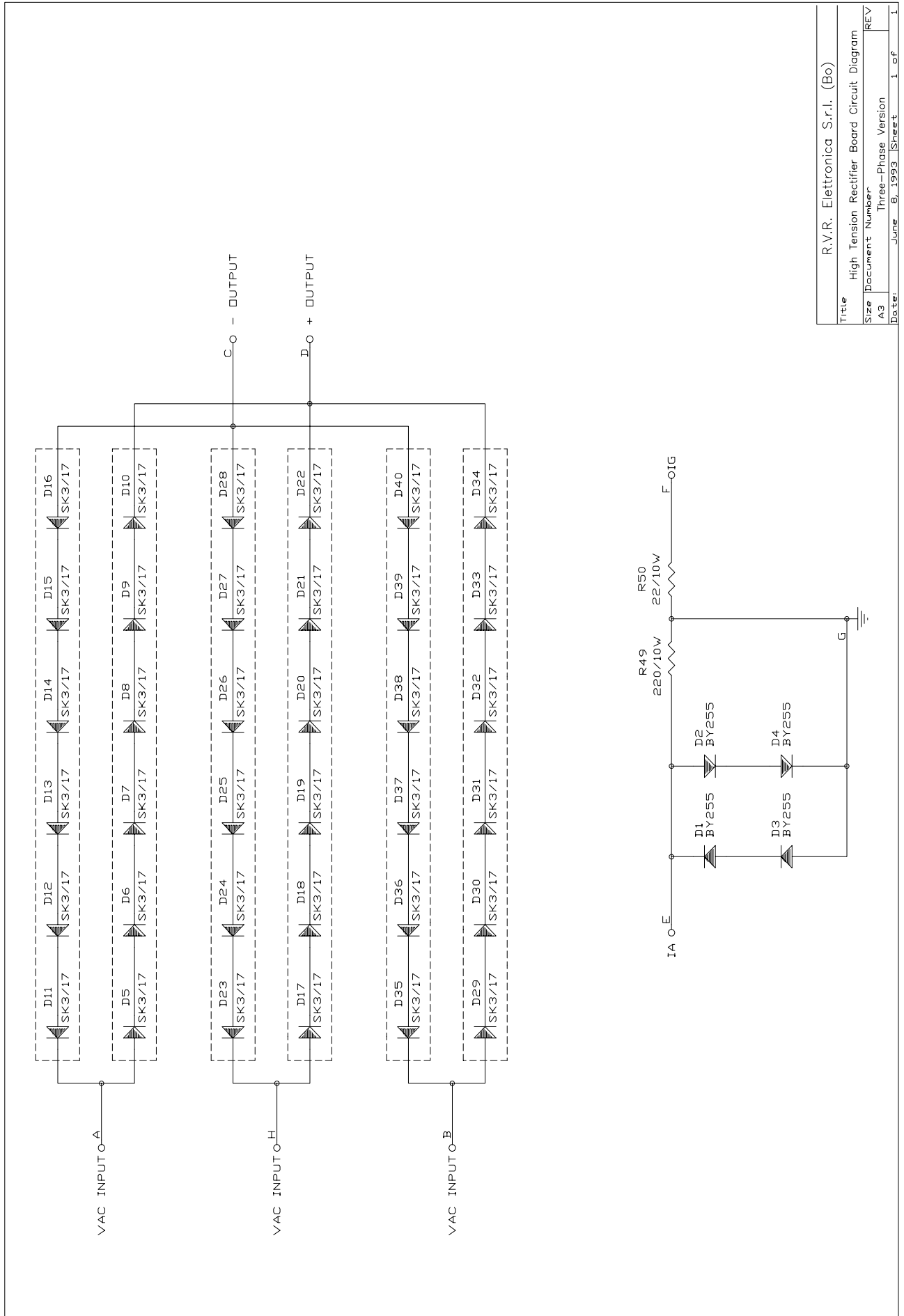

Title R.V.R. Elettronica S.r.l. (Bo)

Size High Tension Rectifier Board Circuit Diagram

Document Number	REV
A3	Three-Phase Version
June 8, 1993	Sheet 1 of 1

Item	Quantity	Reference	Part	Description	Part Order Code
1	1	R50	22/10W	RESISTOR 10W	RAF010KH0022
2	1	R49	220/10W	RESISTOR 10W	RAF010KH0220
3	4	D1,D2,D3,D4	BY255	SILICON DIODE 1000V 3A	DISBY255
4	36	D5,D6,D7, D8,D9,D10, D11,D12,D13, D14,D15,D16, D17,D18,D19, D20,D21,D22, D23,D24,D25, D26,D27,D28, D29,D30,D31, D32,D33,D34, D35,D36,D37, D38,D39,D40	SK3/17	SEMICRON DIODE 3A 1K7V	DISSK3/17

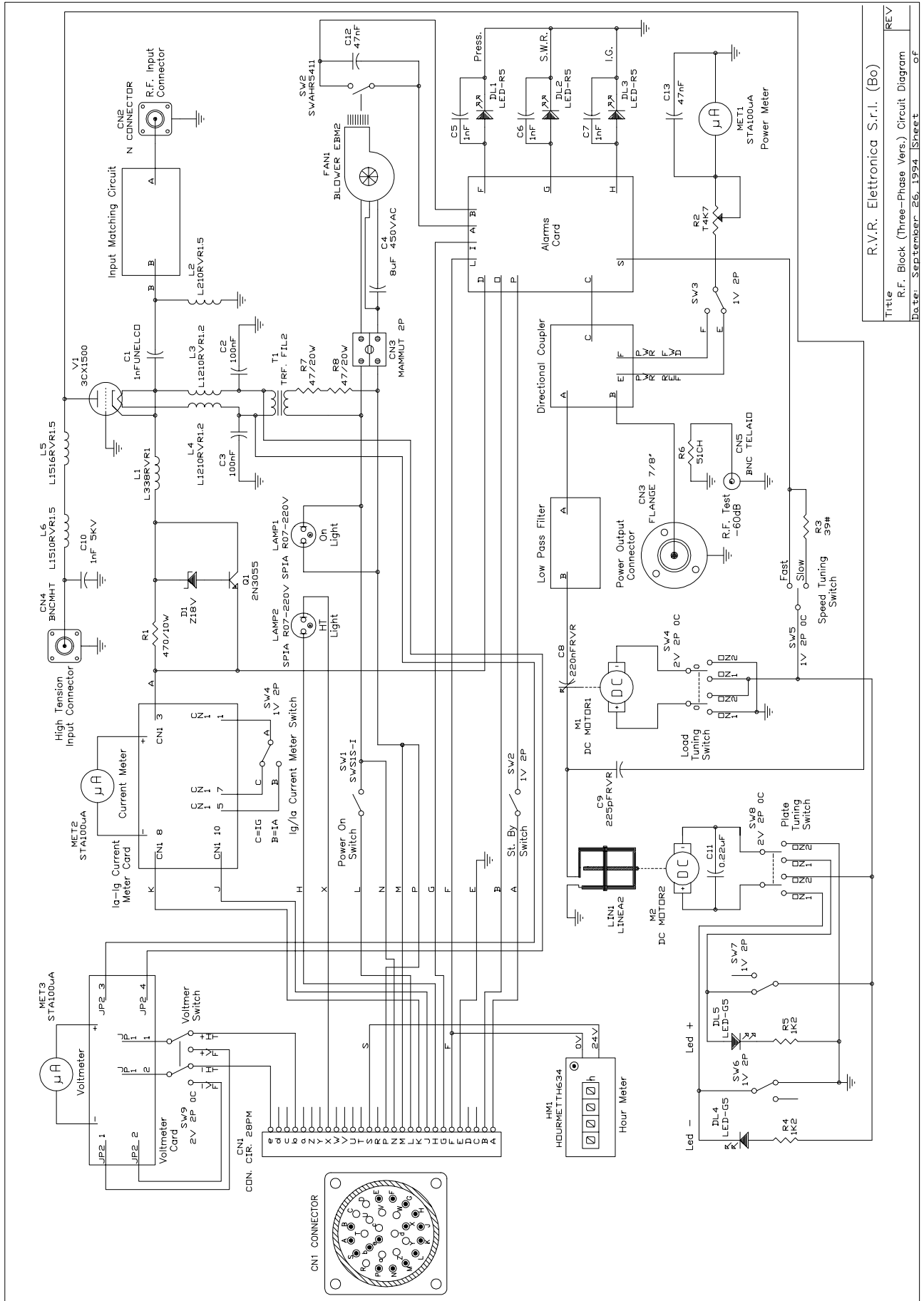

R.V.R. Elettronica S.r.l. (Bo)	
Title	R.F. Block (Three-Phase Vers.) Circuit Diagram
Date	September 26, 1994 Sheet
REV	OF

Item	Quantity	Reference	Part	Description	Part Order Code
1	1	R3	39#	RESISTOR 2W	RSC002JH0039
2	1	R6	51CH	CHIP RESISTOR	RCC1/4JH0051
3	2	R7,R8	47/20W	RESISTOR 20W	RAF020KH0047
4	1	R1	470/10W	RESISTOR 10W	RAF010KH0470
5	2	R4,R5	1K2	RESISTOR 1/4W 5%	RSC1/4JK01,2
6	1	R2	T4K7	TRIMMER REG. VERT. 10mm	RVTD10VK04,7
7	1	C9	225pFRVR	CERAMIC CAP. RVR	CKM225BRVR
8	3	C5,C6,C7	1nF	CERAMIC CAPACITOR	CKM102BK600P
9	1	C1	1nFUNELCO	SILVER MICA CAPACITOR	CSM102XK351
10	1	C10	1nF 5KV	HT CERAMIC CAPACITOR	CHT102B5000V
11	2	C12,C13	47nF	CERAMIC CAPACITOR	CKM473BK600P
12	2	C2,C3	100nF	CERAMIC CAPACITOR	CKM104BK600P
13	1	C8	220nFRVR	CERAMIC CAP. RVR	CKM224BRVR
14	1	C11	0.22µF	POLIESTER CAPACITOR	CPE224DK101
15	1	C4	8µF 450VAC	HIGH VOLTAGE CAPACITOR	CHV0400V0008
16	2	L3,L4	L1210RVR1.2	12SP D.10 RAME S. 1.2mm	BFS12001210
17	1	L5	L1516RVR1.5	15SP D.16 RAME S. 1.5mm	BFS15001516
18	1	L6	L1510RVR1.5	15SP D.10 RAME S.1.5mm	BFS15001510
19	1	L2	L210RVR1.5	2 SP D.10 RAME A. 1.5mm	BFS15000210
20	1	L1	L338RVR1	33SP D. 8 RAME S. 1mm	BFS10003308
21	3	MET1,MET2, MET3	STA250UA	STRUMENTO 250uA	SMABM55RQ251
22	1	HM1	HOURLMETH634	H.M. MATSH. TH634 24V	SHMTH634
23	1	CN3	MAMMUT 2P	MORS. MP MONT. DIRET.2P	MORMP2P
24	1	CN1	C.CIR.28PM	CON. CIRC. 28P BULGIN M	CNTBLCCM28P
25	1	CN5	BNC TELAIO	CONN. BNC A TELAIO	CNTBNCFPV
26	1	CN4	BNCMHT	CONN. BNC MAS. PER HT	CNTBNCMHT
27	1	CN2	N CONNECTOR	CONN. N A TELAIO	CNTNFPFL
28	1	CN3	FLANGE 7/8"	FLANGE 7/8"	CNTFL7/8
29	5	SW2,SW3, SW4,SW6,SW7	1V 2P	DEVIATORE 1 VIA 2 POS	DEV1V1103CS
30	1	SW5	1V 2P 0C	DEV. 1 VIA 2 POS 0 CENT	DEV2V1M01M03
31	3	SW4,SW8,SW9	2V 2P 0C	DEV. 2 VIE 2 POS 0 CENT	DEV2V1M01M03
32	1	SW1	SWS1S-I	DEV. FEME 250VAC 15A	DEVSW1S-I
33	1	SW2	SWAHR5411	MICROINT. NAT. AHR5411	DEVAHR5411
34	2	LAMP1,LAMP2	SPIA R07-220V	SPIA AL NEON 220V ROSSA	SPIA07RO220

35	3	DL1,DL2,DL3	LED-R5	RED LED DIODE	LEDRO05
36	2	DL4,DL5	LED-G5	GREEN LED DIODE	LEDVE05
37	1	D1	Z12V	ZENER DIODE 12V 0.4W	DIZ12V0W4
38	1	LIN1	LINEA2	LINEA VJ2000	LINVJ2000
39	1	M1	DC MOTOR1	MOT BUH. 1.61.013.325-W	MOTRCVJ200
40	1	M2	DC MOTOR2	MOT BUH. 1.61.013.330-0	MOTRPVJ200
41	1	Q1	BUV22	NPN SILICON TRANSISTOR	TRNBUV22
42	1	T1	TRF. FIL2	TRF. 220/5V 60VA	TRFFILVJ2000
43	1	FAN1	BLOWER EBM2	VENT. EBM G2E180AA0301	VTLEBMG2E180
44	1	V1	3CX1500	VALV. 3CX1500 EIMAC TR.	VAL3CX1500

Pagina lasciata intenzionalmente in bianco
This page was intentionally left blank

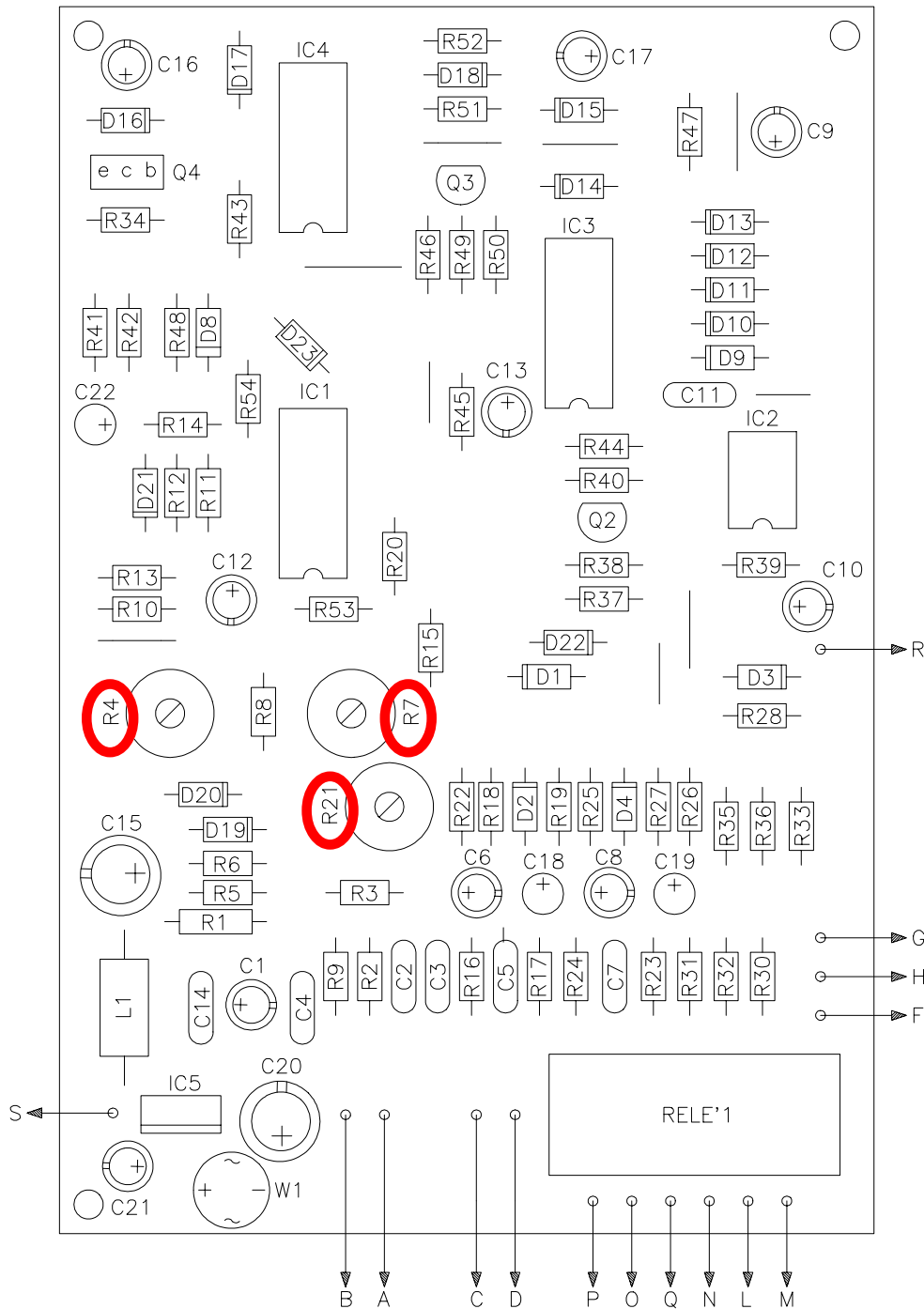

	DENOMINAZIONE	
	Alarms Card Component Layout / Piano di Montaggio	
	DISPOSITIVO	
SEMILAVORATO	DISEGNATO	DISEGNO
MATERIALE	D'Alessio D.ii	
TRATTAMENTO	SCALA	TAVOLA n di

R4	Taratura della Pressione della Turbina // Calibration of the Fan Pressure Alarm Threshold	p.32
R7	Taratura del R.O.S. // Calibration of the V.S.W.R.	p.32
R21	Taratura dell'Intervento della Protezione della Corrente di Griglia // Calibration of the Grid Current Alarm Threshold	p.33

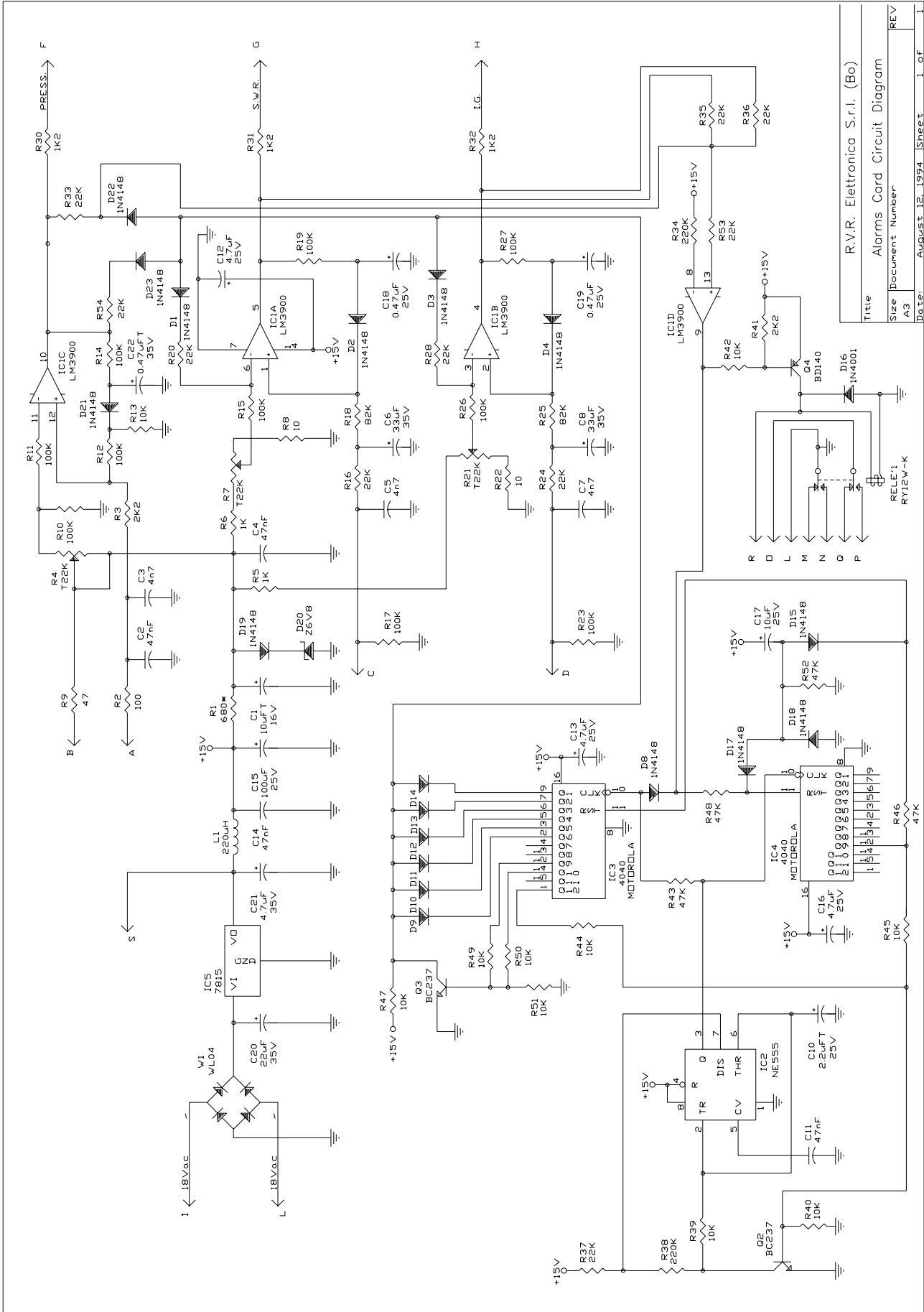

Title	R.V.R. Elettronica S.r.l. (Bo)
Size	Alarms Card Circuit Diagram
Document Number	A3
REV	REV
Date	August 12, 1994
Sheet	1 of 1

Item	Quantity	Reference	Part	Description	Part Order Code
1	2	R8,R2210		RESISTOR 1/4W 5%	RSC1/4JH0010
2	1	R9	47	RESISTOR 1/4W 5%	RSC1/4JH0047
3	1	R2	100	RESISTOR 1/4W 5%	RSC1/4JH0100
4	1	R1	680*	RESISTOR 1/2W 5%	RSC1/2JH0680
5	2	R5,R6	1K	RESISTOR 1/4W 5%	RSC1/4JK0001
6	3	R30,R31,R32	1K2	RESISTOR 1/4W 5%	RSC1/4JK01,2
7	2	R3,R412K2		RESISTOR 1/4W 5%	RSC1/4JK02,2
8	10	R13,R39, R40,R42, R44,R45, R47,R49, R50,R51	10K	RESISTOR 1/4W 5%	RSC1/4JK0010
9	10	R16,R20, R24,R28, R33,R35, R36,R37, R53,R54	22K	RESISTOR 1/4W 5%	RSC1/4JK0022
10	4	R43,R46, R48,R52	47K	RESISTOR 1/4W 5%	RSC1/4JK0047
11	2	R18,R25	82K	RESISTOR 1/4W 5%	RSC1/4JK0082
12	10	R10,R11, R12,R14, R15,R17, R19,R23, R26,R27	100K	RESISTOR 1/4W 5%	RSC1/4JK0100
13	2	R34,R38	220K	RESISTOR 1/4W 5%	RSC1/4JK0220
14	3	R4,R7,R21	T22K	TRIMMER REG. VERT. 10mm RVTD10VK0022	
15	3	C3,C5,C7	4n7	CERAMIC CAPACITOR	CKM472BK600P
16	4	C2,C4,C11, C14	47nF	CERAMIC CAPACITOR	CKM473BK600P
17	2	C18,C19	0.47µF	POLIESTER CAPACITOR	CPE474EK101
18	1	C22	0.47µFT	TANTALIUM CAPACITOR	CET474AM350
19	1	C10	2.2µFT	TANTALIUM CAPACITOR	CET225AM350
20	4	C12,C13, C16,C21	4.7µF	ELECTROLYTIC CAPACITOR	CEA475AM350
21	1	C17	10µF	ELECTROLYTIC CAPACITOR	CEA106AM350
22	1	C1	10µFT	TANTALIUM CAPACITOR	CET106AM350
23	1	C20	22µF	ELECTROLYTIC CAPACITOR	CEA226BM350
24	2	C6,C8	33µF	ELECTROLYTIC CAPACITOR	CEA336BM350
25	1	C15	100µF	ELECTROLYTIC CAPACITOR	CEA107BM350
26	1	L1	220µH	RF CHOKE	IMP220UA
27	1	RELE'1RY12W-K	RELAY 2V 12V	TAKAMISAWA RLDRY12W-K	

28	18	D1,D2,D3, D4,D8,D9, D10,D11, D12,D13, D14,D15, D17,D18, D19,D21, D22,D23	1N4148	SILICON DIODE	DIS1N4148
29	1	D16	1N4001	SILICON DIODE 50V	DIS1N4001
30	1	W1	WL04	DIODE BRIDGE 1.5A	PNRWL04
31	1	D20	Z6V8	ZENER DIODE 6.8V 0.4W	DIZ6V80W4
32	1	IC5	7815	POS. STABILIZER 1A	CIL7815P
33	2	Q2,Q3	BC237	NPN TRANSISTOR	TRNBC237
34	1	Q4	BD140	PNP TRANSISTOR	TRNBD140
35	1	IC2	NE555	TIMER	CIL555
36	2	IC3,IC4	4040	CMOS DIVIDER MOTOROLA	CID4040
37	1	IC1	LM3900	NORTON QUAD AMP.	CILLM3900

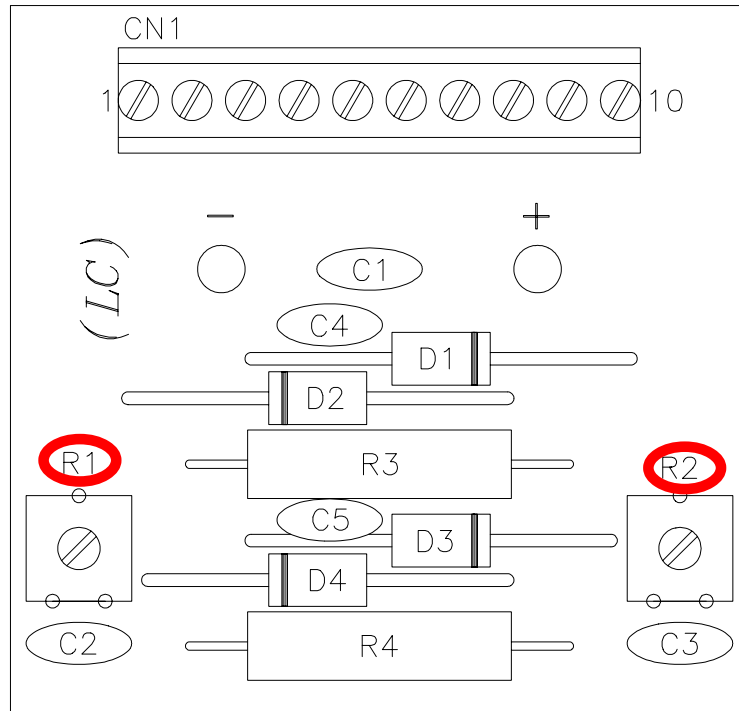

	DENOMINAZIONE	
	Grid/Plate Current Meter Card Component Layout / Piano di Montaggio	
	DISPOSITIVO	
SEMILAVORATO	DISEGNATO	DISEGNO
MATERIALE	D'Alessio D. U.	
TRATTAMENTO	SCALA	TAVOLA n di

R1

Calibrazione della Misura di Corrente Anodica // Calibration of the Anode Current Measurement

p.34

R2

Calibrazione della Misura Corrente di Griglia // Calibration of the Grid Current Measurement

p.34

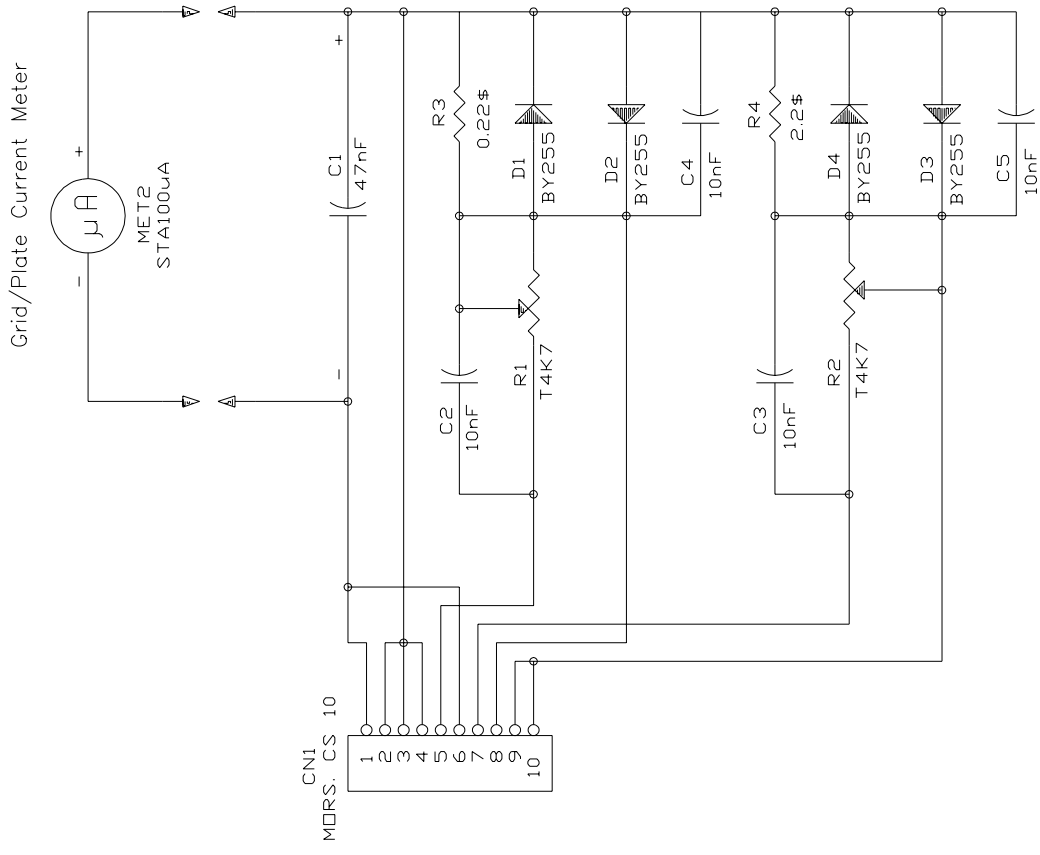

- CN1 1 Connected to a Contact Current Meter Switch
- CN1 2 Connected to D Contact Alarms Card
- CN1 3 Connected to A Contact R.F. Cavity
- CN1 4 Not Connected
- CN1 5 Connected to b Contact Current Meter Switch
- CN1 6 Not Connected
- CN1 7 Connected to c Contact Current Meter Switch
- CN1 8 Connected to K Contact Power Supply Connector
- CN1 9 Not Connected
- CN1 10 Connected to J Contact Power Supply Connector

IA = Corrente Anodica = Plate Current
 IG = Corrente di Griglia = Grid Current

R.V.R. Elettronica S.r.l. (Bo)	
Title	Ia-Ig Meter Card Circuit Diagram
Size	Document Number
A4	REV
Date:	August 16, 1994
Sheet	of

Ia-Ig Meter Card *Bill of Materials/Lista Componenti* *Pag. 1*

<i>Item</i>	<i>Quantity</i>	<i>Reference</i>	<i>Part</i>	<i>Description</i>	<i>Part Order Code</i>
1	1	R3	0.22\$	RESISTOR 5W	RAF005JH0,22
2	1	R4	2.2\$	RESISTOR 5W	RAF005JH02,2
3	2	R1,R2	T4K7	TRIMMER REG. VERT. 10mm	RVTD10VK04,7
4	4	C2,C3,C4,C5	10nF	CERAMIC CAPACITOR	CKM103BK600P
5	1	C1	47nF	CERAMIC CAPACITOR	CKM473BK600P
6	1	MET2	STA100µA	STRUMENTO 100µA	SMABM55RQ101
7	1	CN1	MORS. CS 10	MORS. CS 10 CONT.	MORSLB10PPO
8	4	D1,D2,D3,D4	BY255	SILICON DIODE 1000V 3A	DISBY255

Pagina lasciata intenzionalmente in bianco
This page was intentionally left blank

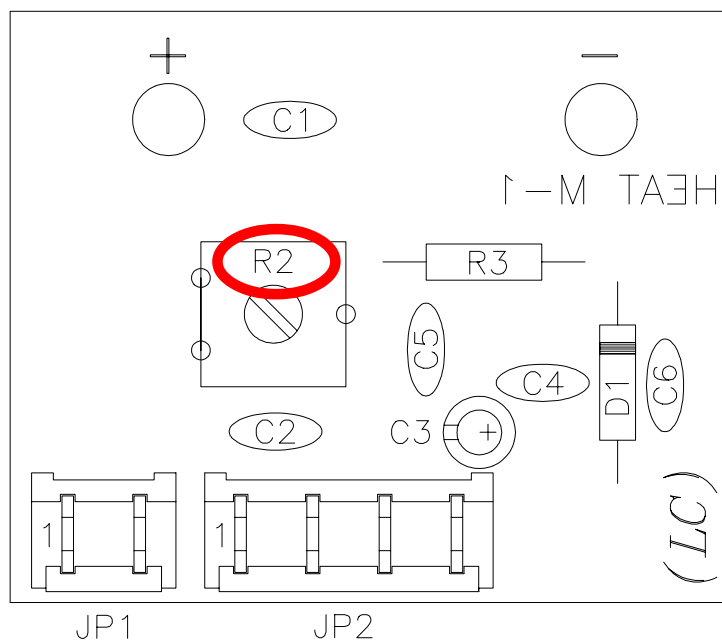

	DENOMINAZIONE	
	Heater Voltage Measure Card and Voltmeter Card Component Layout / Piano di Montaggio	
DISPOSITIVO		
SEMILAVORATO	DISEGNATO	DISEGNO
MATERIALE	D'Alessio D. U.	
TRATTAMENTO	SCALA	TAVOLA n di

R2

Calibrazione della misura della Tensione di Filamento //

Calibration of the Heater Voltage Measurement

p.34

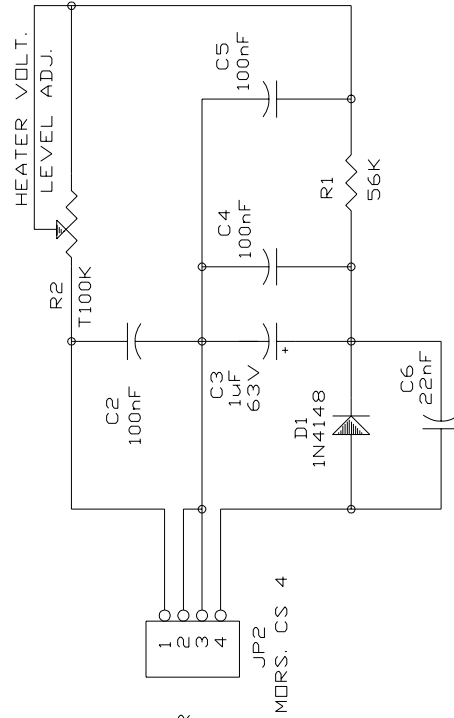
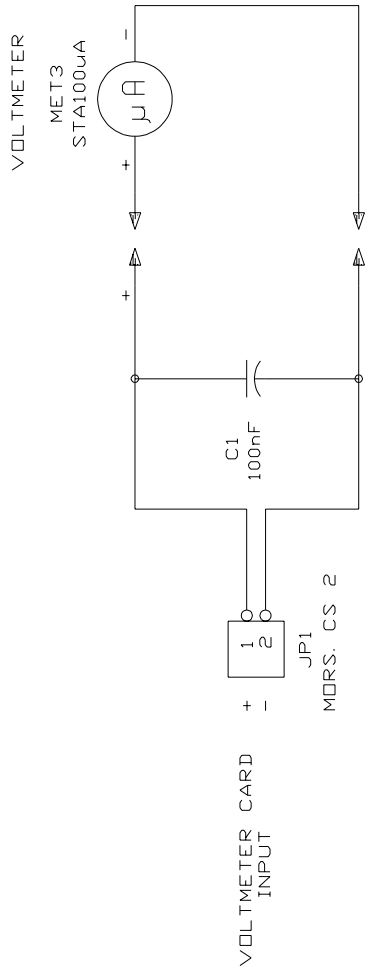



JP1 1 -> OUTPUT (<+> FOR VOLTMETER
 JP1 2 -> OUTPUT (<-> FOR VOLTMETER
 JP1 3 -> HEATER INPUT V_{ac}
 JP1 4 -> HEATER INPUT V_{ac}

R.V.R. Electronica S.r.l. (Bo)	
Title	Heater Voltage Measure Card and Voltmeter Card Circuit Diagram
Size	Document Number
A4	REV
Date:	August 12, 1994
Sheet	1 of 1

<i>Item</i>	<i>Quantity</i>	<i>Reference</i>	<i>Part</i>	<i>Description</i>	<i>Part Order Code</i>
1	1	R1	56K	RESISTOR 1/4W 5%	RSC1/4JK0056
2	1	R2	T100K	TRIMMER REG. VERT. 10mm	RVTD10VK0100
3	4	C1,C2,C4,C5	100nF	CERAMIC CAPACITOR	CKM104BK600P
4	1	C6	22nF	CERAMIC CAPACITOR	CKM224BK600P
5	1	C3	1 μ F	ELECTROLYTIC CAPACITOR	CEA105AM630
6	1	MET3	STA100 μ A	STRUMENTO 100 μ A	SMABM55RQ101
7	1	JP1	MORS. CS 2	MORS. C. S. 2 CONT	MORSKB02PPO
8	1	JP2	MORS. CS 4	MORS. C. S. 4 CONT.	MORSKB04PPO
9	1	D1	1N4148	SILICON DIODE	DIS1N4148

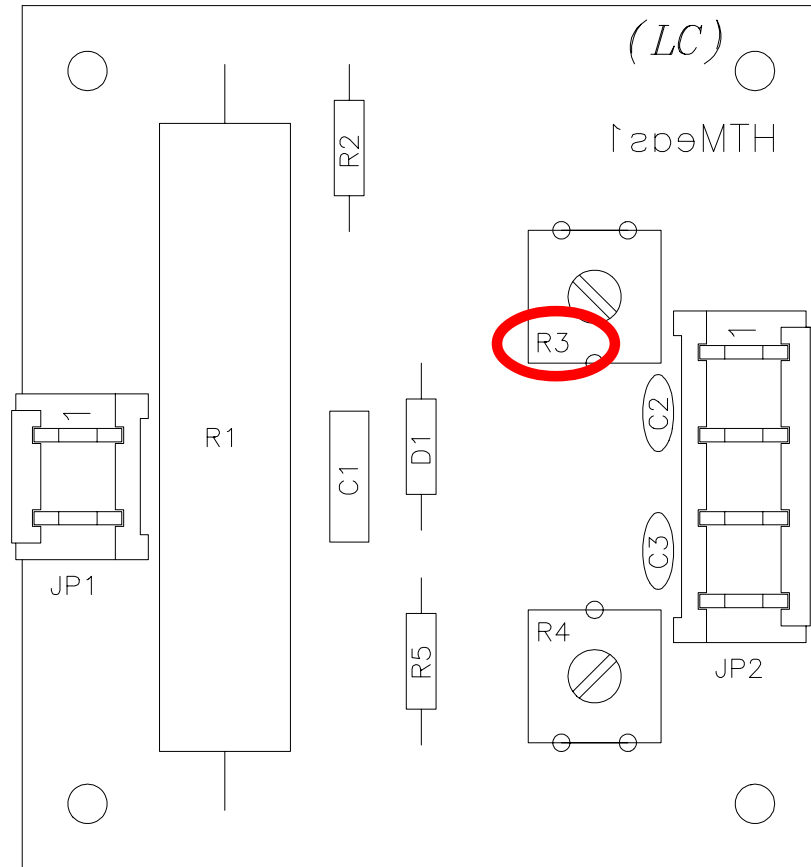
Pagina lasciata intenzionalmente in bianco
This page was intentionally left blank



	DENOMINAZIONE	
	Plate Voltage Measure Card Component Layout / Piano di Montaggio	
DISPOSITIVO		
SEMILAVORATO	DISEGNATO	DISEGNO
MATERIALE	D'Alessio D. U	
TRATTAMENTO	SCALA	TAVOLA n di

R3	Calibrazione della Misura della Tensione di Griglia //	
	Calibration of the Plate Voltage Measurement	p.35

R3 -> PLATE VOLT. LEVEL ADJ. FOR VOLTMETER CARD
 R4 -> PLATE VOLT. LEVEL ADJ. FOR TELEMETRY CARD

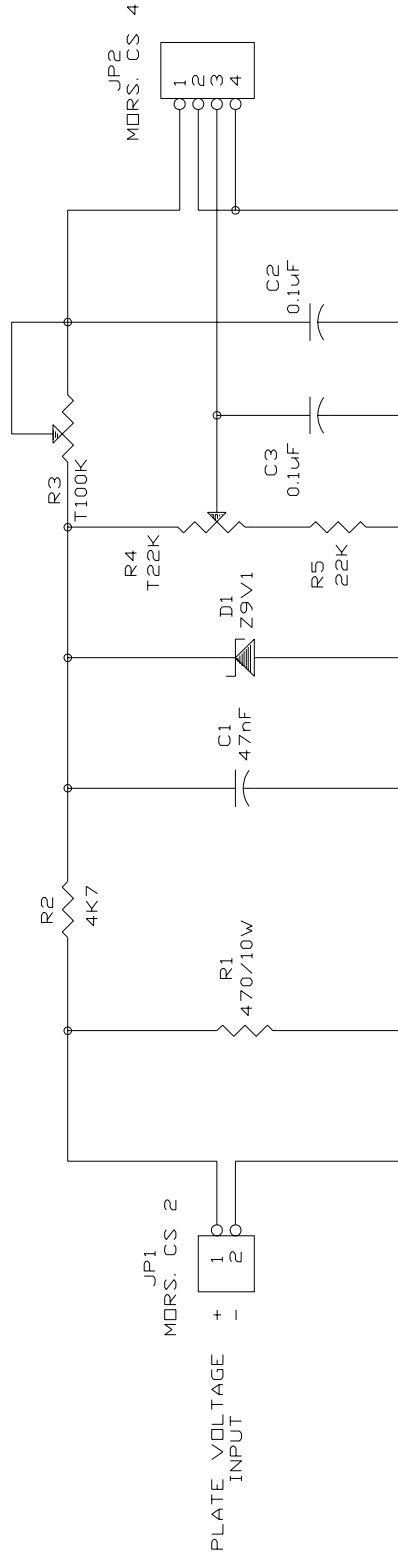

JP2 1 -> OUTPUT (+) FOR VOLTMETER CARD
 JP2 2 -> OUTPUT (-) FOR VOLTMETER CARD
 JP2 3 -> OUTPUT (+) FOR TELEMETRY CARD
 JP2 4 -> OUTPUT (-) FOR TELEMETRY CARD

R.V.R. Electronica S.r.l. (Bo)

Title		R.V.R. Electronica S.r.l. (Bo)	
Plate Voltage Measure Card Circuit Diagram			
Size	Document Number	REV	
A4			
Date:	August 16, 1994	Sheet	1 of 1

<i>Item</i>	<i>Quantity</i>	<i>Reference</i>	<i>Part</i>	<i>Description</i>	<i>Part Order Code</i>
1	1	R1	470/10W	RESISTOR 10W	RAF010KH0470
2	1	R2	4K7	RESISTOR 1/4W 5%	RSC1/4JK04,7
3	1	R5	22K	RESISTOR 1/4W 5%	RSC1/4JK0022
4	1	R4	T22K	TRIMMER REG. VERT. 10mm	RVTD10VK0022
5	1	R3	T100K	TRIMMER REG. VERT. 10mm	RVTD10VK0100
6	1	C1	47nF	CERAMIC CAPACITOR	CKM473BK600P
7	2	C2,C3	0.1µF	CERAMIC CAPACITOR	CKM104BK600P
8	1	JP1	MORS. CS 2	MORSETTIERA CS 2 CONT	MORSKB02PPO
9	1	JP2	MORS. CS 4	MORSETTIERA CS 4 CONT.	MORSKB04PPO
10	1	D1	Z9V1	ZENER DIODE 9.1V 1W	DIZ9V11W

Pagina lasciata intenzionalmente in bianco
This page was intentionally left blank

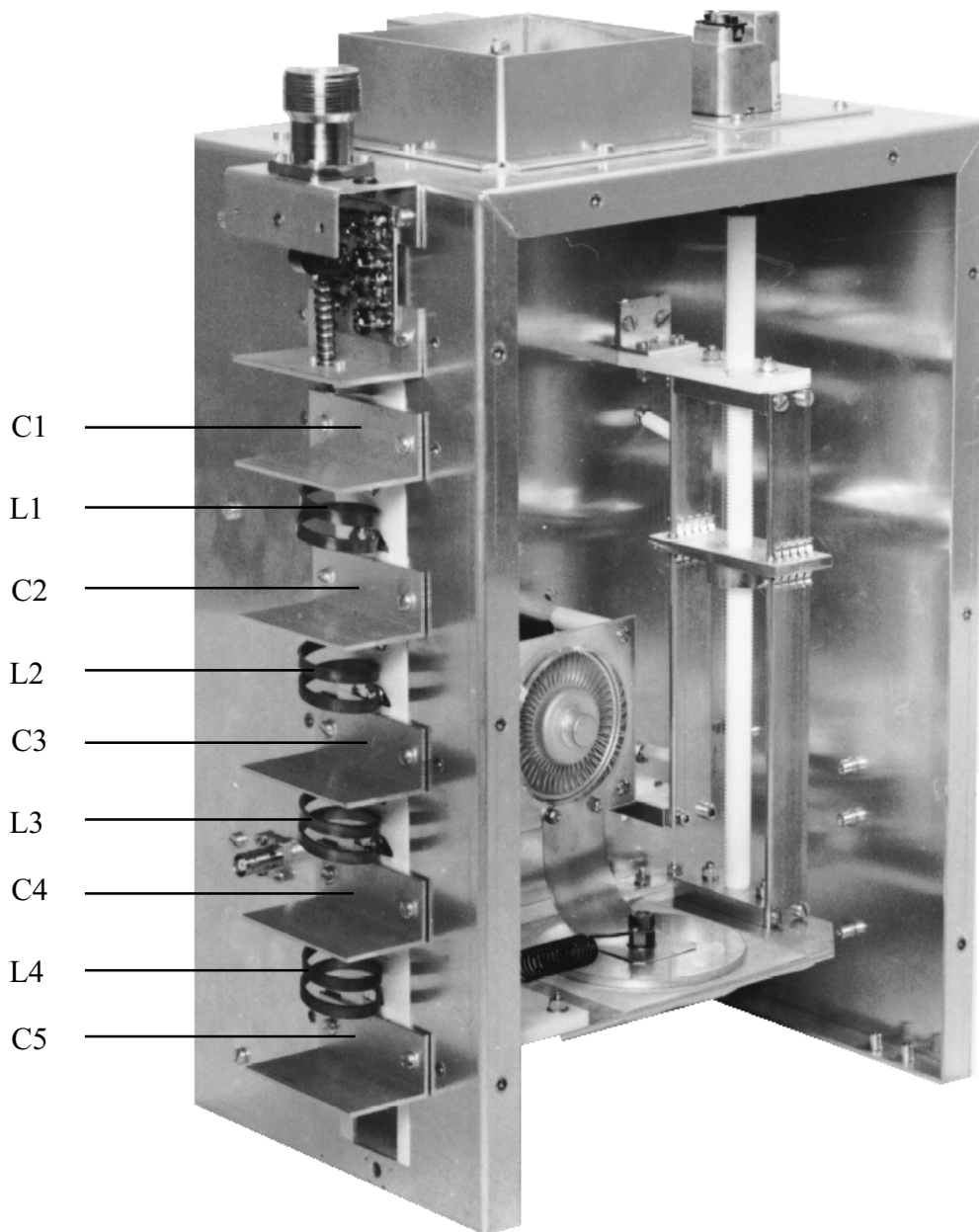

COMPONENT DISPOSITION / DISPOSIZIONE DEI COMPONENTI

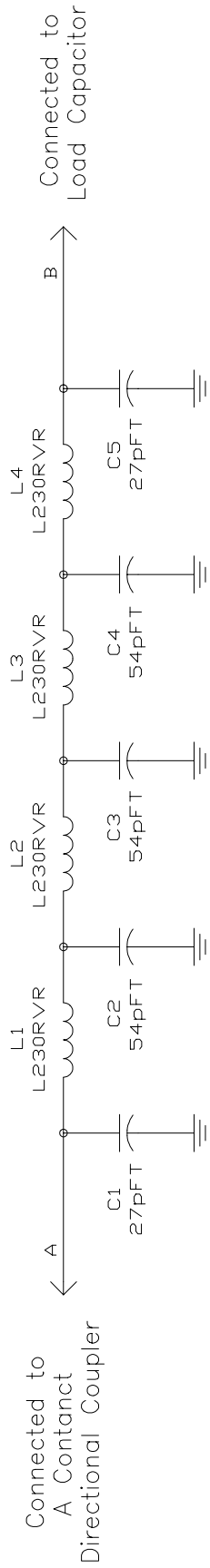

Title		R.V.R. Elettronica S.r.l. (Bo)	
Size		A4	
Document Number		REV	
Date:	Sheet	of	

<i>Item</i>	<i>Quantity</i>	<i>Reference</i>	<i>Part</i>	<i>Description</i>	<i>Part Order Code</i>
1	2	C1,C5	27pFT	COND. BAND RAME TEFLON	CBRT270RVR
2	3	C2,C3,C4	54pFT	COND. BAND RAME TEFLON	CBRT540RVR
3	4	L1,L2,L3,L4	L230RVR	2 SP DIA 30 BAND. RAME	BBR5000230

Pagina lasciata intenzionalmente in bianco
This page was intentionally left blank

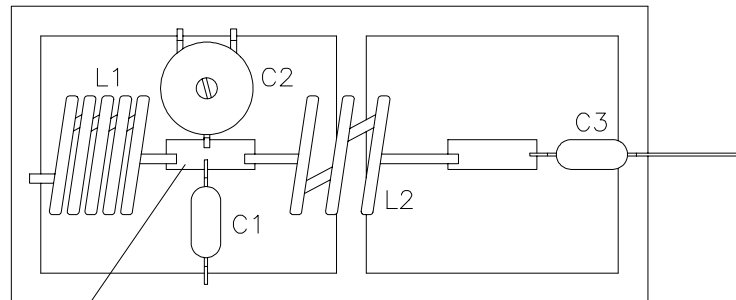

Connected to
R.F. Input
Connector

Connected to
B Contact
C1 Capacitor
R.F. Block

	DENOMINAZIONE Input Matching Circuit Component Layout / Piano di Montaggio	
	DISPOSITIVO	
SEMILAVORATO	DISEGNATO D'Alessio D.lli	DISEGNO
MATERIALE	SCALA	TAVOLA n di
TRATTAMENTO		

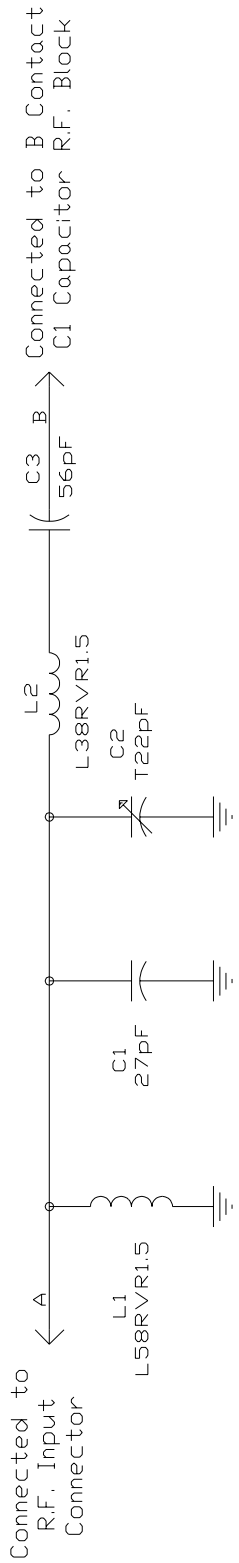

Title		R.V.R. Elettronica S.r.l. (Bo)	
Size		Input Matching Circuit Diagram	
Document Number	REV		
A4			
Date:		Sheet	of

<i>Item</i>	<i>Quantity</i>	<i>Reference</i>	<i>Part</i>	<i>Description</i>	<i>Part Order Code</i>
1	1	C2	T22pF	TRIMMER CAPACITOR	CVF220CK600
2	1	C1	27pF	CERAMIC CAPACITOR NP0	CKM270BJ600C
3	1	C3	56pF	CERAMIC CAPACITOR NP0	CKM560BJ600C
4	1	L1	L58RVR1.5	5 SP DIA 8 R. AR. 1.5mm	BFS15000508
5	1	L2	L38RVR1.5	3 SP DIA 8 R. AR. 1.5mm	BFS15000308

Pagina lasciata intenzionalmente in bianco
This page was intentionally left blank

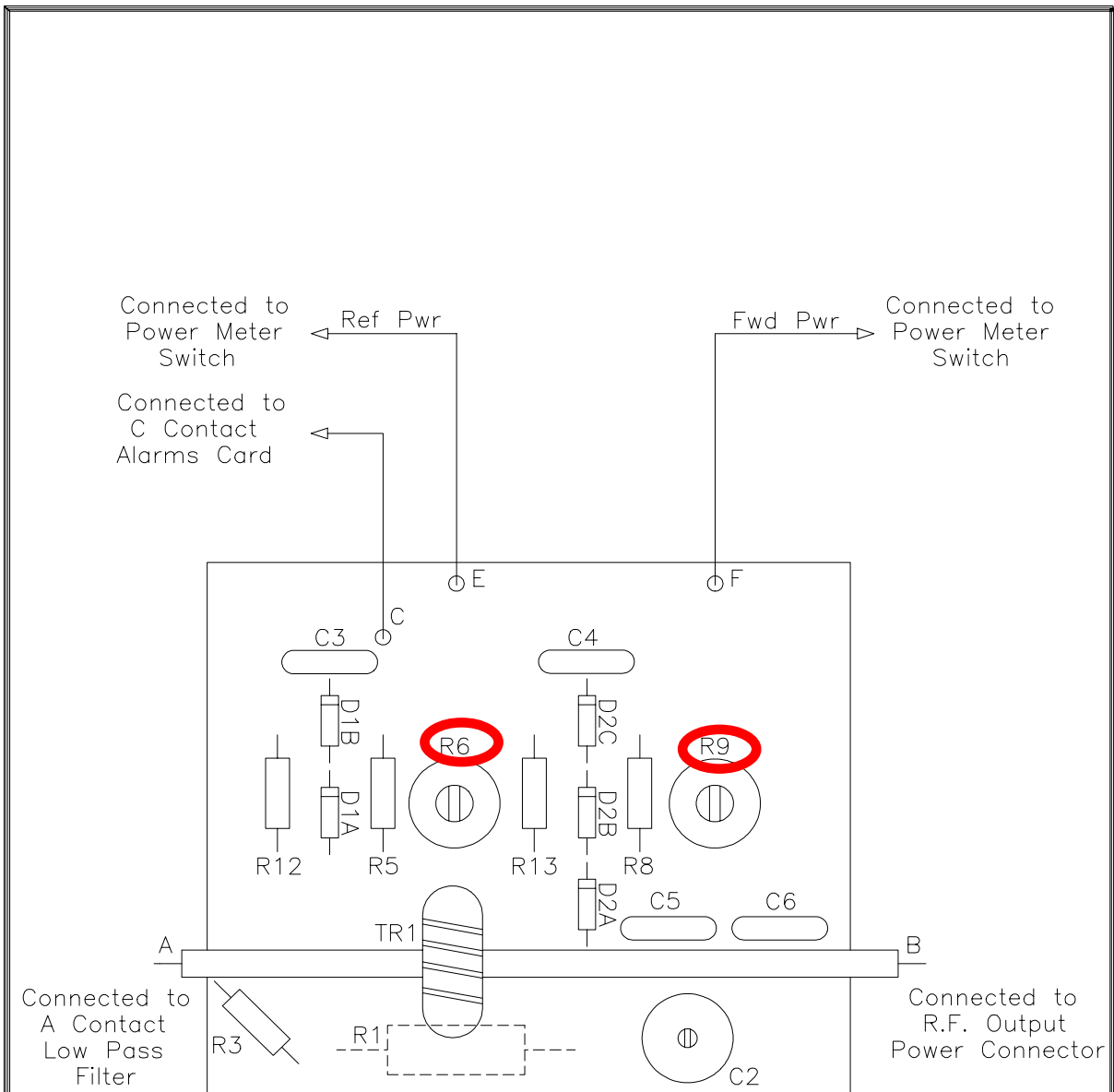

	DENOMINAZIONE		
	Directional Coupler Card Layout / Piano di Montaggio		
	DISPOSITIVO		
SEMILAVORATO	DISEGNATO	DISEGNO	
MATERIALE	D'Alessio D.u		
TRATTAMENTO	SCALA	TAVOLA n 1 di 1	

R6	Calibrazione della Lettura della Potenza Riflessa //	
	Calibration of the Measurement of the Reflected Power	p.36
R9	Calibrazione della Lettura della Potenza Diretta //	
	Calibration of the Measurement of the Forward Power	p.35

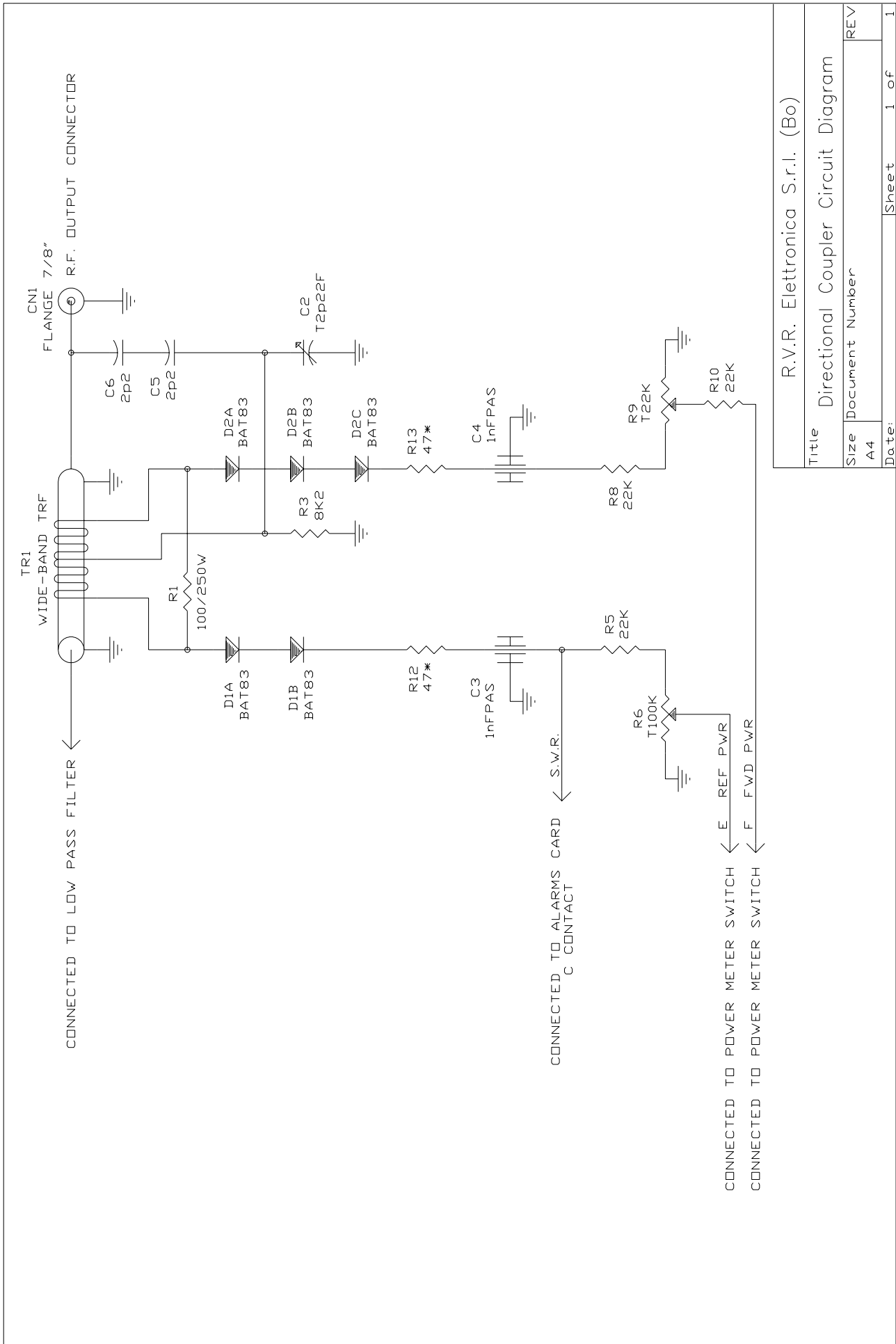

<i>Directional Coupler</i>		<i>Bill of Materials/Lista Componenti</i>		<i>Pag. 1</i>	
<i>Item</i>	<i>Quantity</i>	<i>Reference</i>	<i>Part</i>	<i>Description</i>	<i>Part Order Code</i>
1	2	R12,R13	47*	RESISTOR 1/2W 5%	RSC1/2JH0047
2	1	R1	100/250W	RESISTOR 250W	RAF250JH0100
3	1	R3	8K2	RESISTOR 1/4W 5%	RSC1/4JK08,2
4	3	R5,R8,R10	22K	RESISTOR 1/4W 5%	RSC1/4JK0022
5	1	R9	T22K	TRIMMER REG. VERT. 10mm	RVTD10VK0022
6	1	R6	T100K	TRIMMER REG. VERT. 10mm	RVTD10VK0100
7	2	C5,C6	2p2	CERAMIC CAPACITOR NP0	CKM2,2BJ600C
8	1	C2	T2p22F	TRIMMER CAPACITOR	CVC2,22CK600
9	2	C3,C4	1nFPAS	CERAMIC THROUGH CAPAC.	CDP102XK500
10	1	CN1	FLANGE 7/8"	FLANGE 7/8"	CNTFL7/8
11	5	D1B,D1A, D2C,D2B,D2A	BAT83	HOT CARRIER DIODE	DHCBAT83
12	1	TR1	WIDE-BAND TRF	WIDE-BAND TRANSFORMER	TRFWIDEBAND

Pagina lasciata intenzionalmente in bianco
This page was intentionally left blank

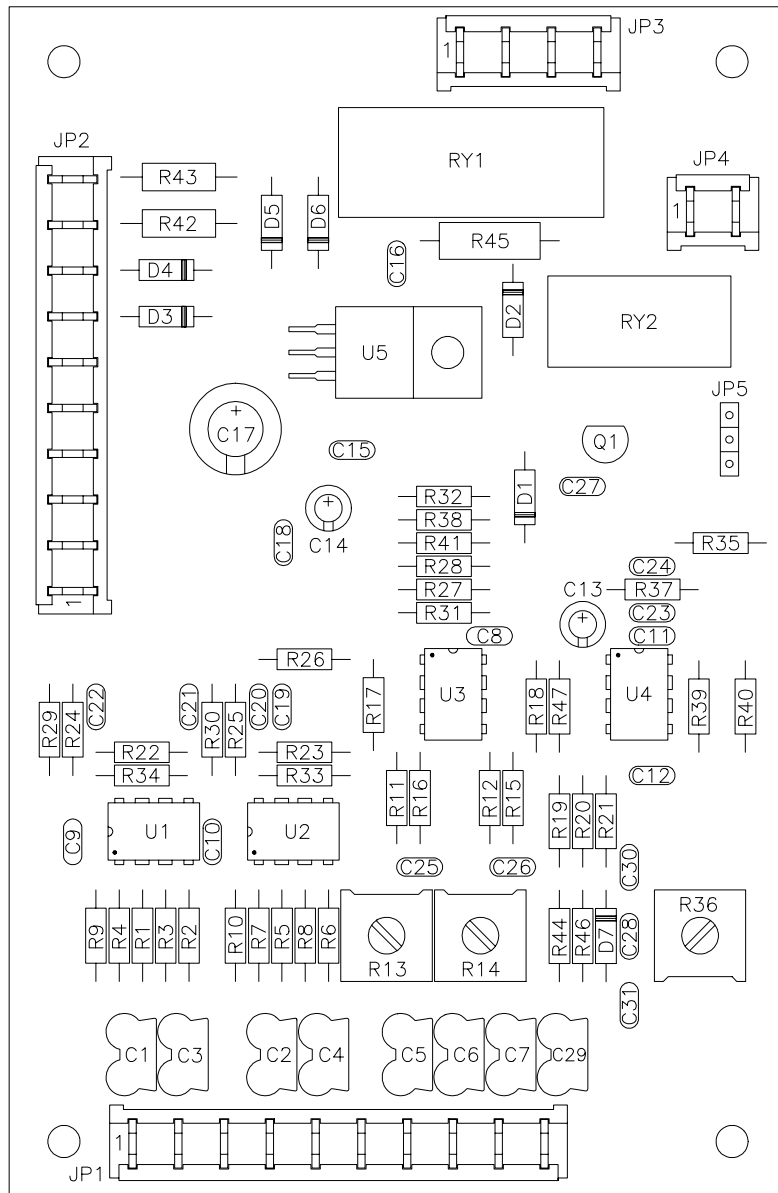

DENOMINAZIONE
Telemetry Card Component Layout / Piano di Montaggio

DISPOSITIVO

SEMILAVORATO

DISEGNATO

DISEGNO

MATERIALE

D'Alessio D. U

TRATTAMENTO

SCALA

TAVOLA n di

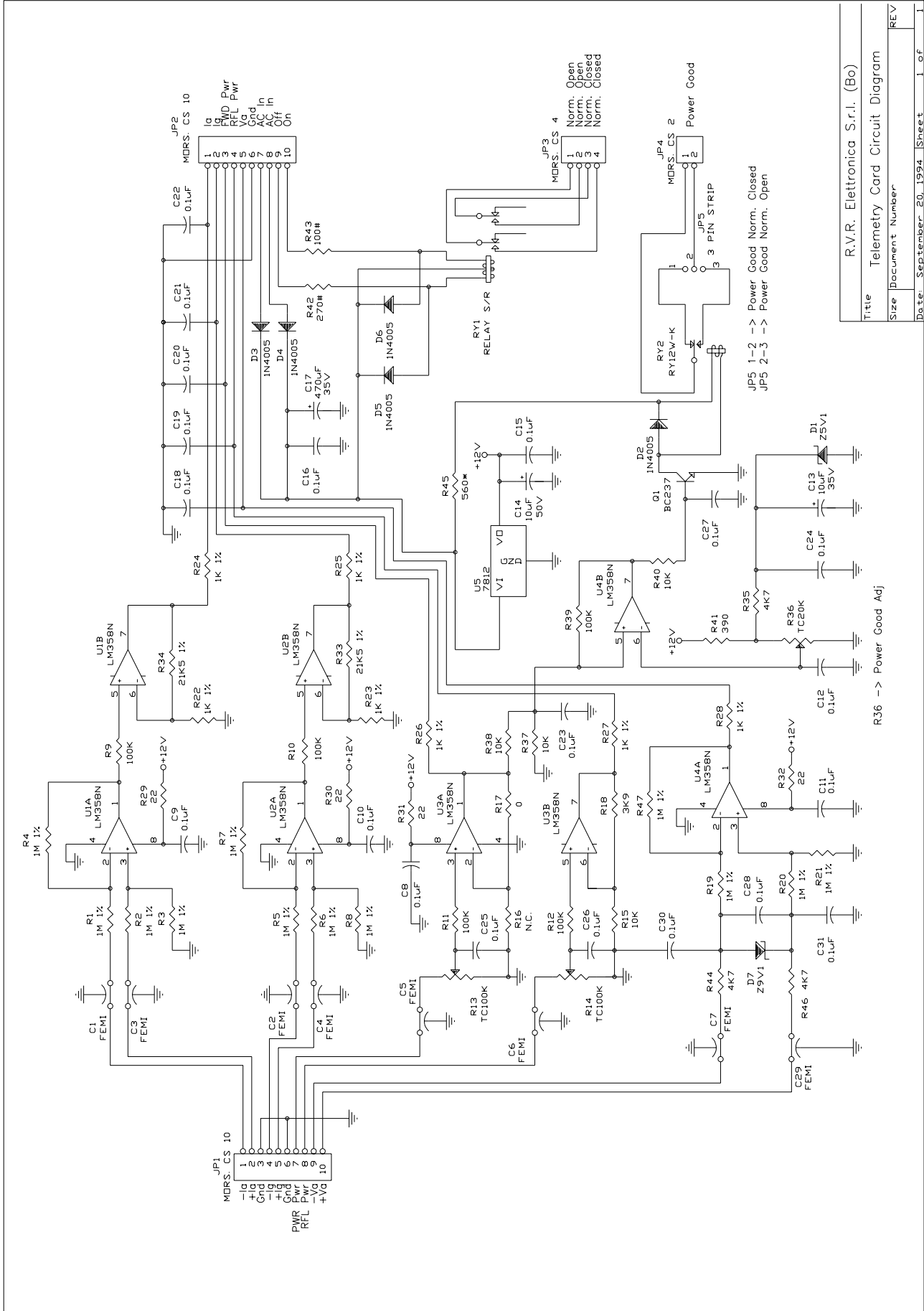

Title	R.V.R. Elettronica S.r.l. (Bo)
Size	Document Number
REV	REV
Date	September 20, 1994
Sheet	1 of 1

Telemetry Card		Bill of Materials/Lista Componenti		Pag. 1	
Item	Quantity	Reference	Part	Description	Part Order Code
1	1	R17	0	0 OHM RESISTOR	R000
2	4	R29,R30, R31,R32	22	RESISTOR 1/4W 5%	RSC1/4JH0022
3	1	R43	100#	RESISTOR 2W	RSC002JH0100
4	1	R42	270#	RESISTOR 2W 5%	RSC002JH0270
5	1	R41	390	RESISTOR 1/4W 5%	RSC1/4JH0390
6	1	R45	560*	RESISTOR 1/2W 5%	RSC1/2JH0560
7	7	R22,R23, R24,R25, R26,R27, R28	1K 1%	RESISTOR 1/4W 1%	RSM1/4FK0001
8	1	R18	3K9	RESISTOR 1/4W 5%	RSC1/4JK03,9
9	3	R35,R44,R46	4K7	RESISTOR 1/4W 5%	RSC1/4JK04,7
10	4	R15,R37, R38,R40	10K	RESISTOR 1/4W 5%	RSC1/4JK0010
11	2	R33,R34	21K5 1%	RESISTOR 1/4W 1%	RSM1/4FK21,5
12	5	R9,R10,R11, R12,R39	100K	RESISTOR 1/4W 5%	RSC1/4JK0100
13	12	R1,R2,R3, R4,R5,R6, R7,R8,R19, R20,R21,R47	1M 1%	RESISTOR 1/4W 1%	RSM1/4FM0001
14	1	R36	TC20K	TRIM. REG. VERT. CERMET	RVTVERVK0020
15	2	R13,R14	TC100K	TRIM. REG. VERT. CERMET	RVTCERVK0100
16	20	C8,C9,C10, C11,C12, C15,C16, C18,C19, C20,C21, C22,C23, C24,C25, C26,C27, C28,C30,C31	0.1 μ F	CERAMIC CAPACITOR	CKM104BK600P
17	2	C13,C14	10 μ F	ELECTROLYTIC CAPACITOR	CEA106AM350
18	1	C17	470 μ F	ELECTROLYTIC CAPACITOR	CEA477BM350
19	1	JP5	3 PIN STRIP	STRIP M P 2.54 3 PIN	CNTSTRIPMCS
20	8	C1,C2,C3, C4,C5,C6, C7,C29	FEMI	FILTRO EMI MURATA	FEAY5S223500
21	1	JP4	MORS. CS 2	MORSETTIERA CS 2 CONT.	MORSKB02PPO
22	1	JP3	MORS. CS 4	MORSETTIERA CS 4 CONT.	MORSKB04PPO
23	2	JP1,JP2	MORS. CS 10	MORSETTIERA CS 10 CONT.	MORSLB10PPO
24	1	RY2	RY12W-K	RELAY 2V 12 TAKAMISAWA	RLDRY12W-K
25	1	RY1	RELAY S/R	RELAY SET / RESET 12V	RLDMZP-R2

26	5	D2,D3,D4, D5,D6	1N4005	SILICON DIODE 600V	DIS1N4005
27	1	D1	Z5V1	ZENER DIODE 5.1V 0.4W	DIZ5V10W4
28	1	D7	Z9V1	ZENER DIODE 9.1V 0.4W	DIZ9V10W4
29	1	Q1	BC237	NPN TRANSISTOR	TRNBC237
30	4	U1,U2,U3,U4	LM358N	DOUBLE OP. AMP.	CILLM358N
31	1	U5	7812	POS. STABILIZER 1A	CIL7812P
32	1	R16	N.C.	NOT CONNECTED	