URP



TECHNICAL AND MAINTENANCE MANUAL



Manufactured by R.V.R. Elettronica - Italy

URP

**Portable FM Exciter 87.5-
108 MHz Range**

Technical and Maintenance Manual

INDEX

<i>Preliminary Instructions and Warranty Informations</i>	<i>Pag. 5</i>
<i>Safety Regulations</i>	<i>Pag. 7</i>

CHAPTER 1

<i>General Description</i>	<i>Pag. 9</i>
<i>Electrical Specifications (Table A)</i>	<i>Pag. 10</i>
<i>Dimensional & Environmental Specifications (Table B)</i>	<i>Pag. 12</i>

CHAPTER 2

<i>Electrical Description</i>	<i>Pag. 13</i>
<i>Front Panel View Description</i>	<i>Pag. 15</i>
<i>Front Panel View (Fig. 1)</i>	<i>Pag. 16</i>
<i>Rear Panel View Description</i>	<i>Pag. 17</i>
<i>Rear Panel View (Fig. 2)</i>	<i>Pag. 18</i>

CHAPTER 3

<i>Installation Procedure</i>	<i>Pag. 19</i>
<i>Main Voltage Connections (Fig. 3)</i>	<i>Pag. 21</i>
<i>Audio Input Connections (Fig. 4)</i>	<i>Pag. 22</i>

APPENDIX A

<i>Circuit Diagrams, Layouts and Bill of Materials</i>	<i>Pag. 23</i>
<i>Card Connections Diagram</i>	<i>Pag. 24</i>
<i>Front Panel Card</i>	<i>Pag. 25</i>
<i>Synthesis Card</i>	<i>Pag. 29</i>
<i>R.F. Amplifier Card</i>	<i>Pag. 34</i>
<i>VCO/AF Card</i>	<i>Pag. 39</i>

PRELIMINARY INSTRUCTIONS AND WARRANTY INFORMATION

WARNING: This equipment is a "CLASS A" equipment. In a residential place this equipment can cause hash. In this case can be requested to user to take the necessary measures.

Please observe safety precautions when handling this unit.
This equipment contains dangerous currents and high voltages.

This manual is written as a general guide for those having previous knowledge and experience with this kind of equipment. It is not intended to contain a complete statement of all safety warnings which should be observed by personnel in using this or other electronic equipment.

R.V.R. doesn't assume responsibility for injury or damage resulting from improper procedures or practices by untrained/unqualified personnel in the handling of this unit.

Please observe all local codes and fire protection standards in the operations of this unit.

CAUTION: always disconnect power before opening covers or removing any part of this unit. Use appropriate grounding procedures to short out capacitors and high voltage points before servicing.

Any damage to the goods must be reported to the carrier in writing on the shipment receipt. Any discrepancy or damage discovered subsequent to delivery, shall be reported to R.V.R. within five (5) days from its receipt.

R.V.R. extends to the original end-user purchaser all original manufacturers warranties which are transferable and all claims are to be made directly to R.V.R. per indicated procedures.

All manufacturers warranties will be supported by R.V.R. to ensure precise and speedy service where possible.

R.V.R. shall not be liable for any damage of whatsoever nature, arising out of or in connection with the product or its use thereof.

R.V.R.'s warranty shall not include:

- 1) Re-shipment of the unit to R.V.R. for repair purposes
- 2) Any unauthorized repair/modification
- 3) Incidental/consequential damages as a result of any defect
- 4) Nominal non-incidentals defects
- 5) Re-shipment costs or insurance of the unit or replacement units/parts

Warranty shall come into force from invoice date and for the period of the manufactures warranty.

The warranty for a period of 12 months is referred to any R.V.R. product, while for products as Transistors, Mos-Fet and Tubes of the final stages is applied the manufacture's warranty off these devices.

To claim your rights under this warranty:

- a. Contact the dealer or distributor where you purchased the unit. Describe the problem and ask if he has an easy solution. Dealers and Distributors are supplied with all the information about problems that may occur and usually they can repair the unit quicker than what the manufacturer could do. Very often installing errors are discovered by dealers.
- b. If your dealer cannot help you, contact R.V.R. in Bologna and explain the problem. If it is decided to return the unit to the factory, R.V.R. will mail you a regular authorization with all the necessary instructions to send back the goods.
- c. When you receive the authorization, you can return the unit. Pack it carefully for the shipment, preferably using the original packing and seal the package perfectly. The customer always assumes the risks of loss (i.e., R.V.R. is never responsible for damage or loss), until the package reaches R.V.R. premises. For this reason, we suggest you to insure the goods for the whole value. Shipment must be effected C.I.F. (PREPAID) to the address specified by R.V.R.'s service manager on the authorization.

DO NOT RETURN UNITS WITHOUT OUR AUTHORIZATION AS THEY WILL BE REFUSED.

Be sure to enclose a written technical report where mention all the problems found and a copy of your original invoice establishing the starting date of the warranty.

Replacement and warranty parts may be order from the following address. Be sure to include the equipment model and serial number as well as part description and part number.

R.V.R. Elettronica S.r.l. - Broadcasting Equipment -
Via del Fonditore, 2/2c
40138 Bologna - Italy
Telephone +39-51-6010506
Fax +39-51-6011104

R.V.R. reserves the right to modify the design and specifications of the equipment in this manual without previous notice.

WARNING!

The currents and voltages in this equipment are dangerous!
Personnel must at all times observe safety regulation!

This manual is intended as a general guide for trained and qualified personnel who are aware of the dangers inherent in handling potentially hazardous electrical and electronic circuits.

It is not intended to contain a complete statement of all safety precautions which should be observed by personnel in using this or other electronic equipment.

The installation, operation, maintenance and service of this equipment involves risks both to personnel and equipment, and must be performed only by qualified personnel exercising due care.

R.V.R. ELETTRONICA S.r.l. shall not be responsible for injury or damage resulting from improper procedures or from the use of improperly trained or inexperienced personnel performing such tasks.

During installation and operation of this equipment, local building codes and fire protection standards must be observed.

WARNING!

Always disconnect power before opening covers, doors, enclosures, gates, panels or shields.
Always use grounding sticks and short out high voltage points before servicing. Never make internal adjustments, perform maintenance or service when alone or when fatigued.

Do not remove, short-circuit or tamper with interlock switches on access covers, doors, enclosures, gates, panels or shields.

Keep away from live circuits, know your equipment and don't take chances.

WARNING!

In case of emergency ensure that power has been disconnected

Treatment of electrical Shock

1) If victim is not responsive follow the A-B-C's of basic life support.

PLACE VICTIM FLAT ON HIS BACK ON A HARD SURFACE

A AIRWAY

IF UNCONSCIOUS,
OPEN AIRWAY

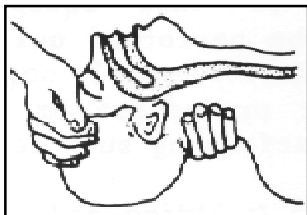

LIFT UP NECK,
PUSH FOREHEAD BACK,
CLEAR OUT MOUTH IF NECESSARY,
OBSERVE FOR BREATHING.

B BREATHING

IF NOT BREATHING,
BEGIN ARTIFICIAL
BREATHING

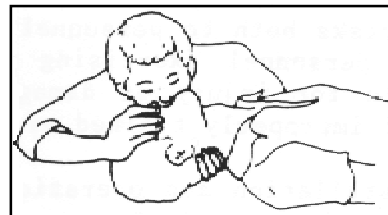

TILT HEAD,
PINCH NOSTRILS,
MAKE AIRTIGHT SEAL,
4 QUICK FULL BREATHS.
REMEMBER MOUTH TO MOUTH
RESUSCITATION MUST BE
COMMENCED AS SOON AS
POSSIBLE.

C CIRCULATION

CHECK CAROTID PULSE

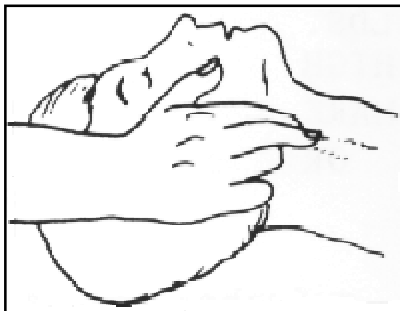

IF PULSE ABSENT,
BEGIN ARTIFICIAL
CIRCULATION

DEPRESS STERNUM 1 1/2" TO 2"

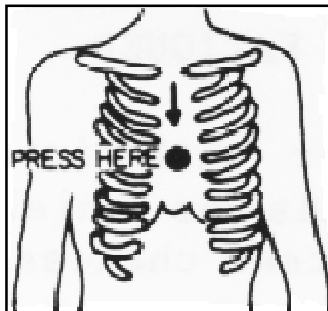

APPROX. 80 SEC. : ONE RESCUER, 15 COMPRESSIONS,
2 QUICK BREATHS.

APPROX. 60 SEC. : TWO RESCUERS, 5 COMPRESSIONS,
1 BREATH

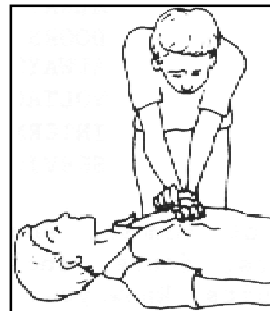

NOTE: DO NOT INTERRUPT RHYTHM OF COMPRESSIONS
WHEN SECOND PERSON IS GIVING BREATH.

Call for medical assistance as soon as possible.

- 2) If victim is responsive.
- Keep them warm.
 - Keep them as quiet as possible.
 - Loosen their clothing (a reclining position is recommended).

FIRST-AID

Personnel engaged in the installation, operation, maintenance or servicing of this equipment are urged to become familiar with first-aid theory and practices. The following information is not intended to be a complete first-aid procedure, it is brief and is only to be used as a reference. It is the duty of all personnel using the equipment to be prepared to give adequate Emergency First Aid and thereby prevent avoidable loss of life.

Treatment of electrical Burns

- 1) Extensive burned and broken skin.
 - a. Cover area with clean sheet or cloth.
(Cleanest available cloth article).
 - b. Do not break blisters, remove tissue, remove adhered particles of clothing, or apply any salve or ointment.
 - c. Treat victim for shock as required.
 - d. Arrange transportation to a hospital as quickly as possible
 - e. If arms or legs are affected keep them elevated.

NOTE

If medical help will not be available within an hour and the victim is conscious and not vomiting, give him a weak solution of salt and soda: 1 level teaspoonful of salt and 1/2 level teaspoonful of baking soda to each quart of water (neither hot or cold).

Allow victim to sip slowly about 4 ounces (half a glass) over a period of 15 minutes.

Discontinue fluid if vomiting occurs (Do not give alcohol).

- 2) Less severe burns - (1st & 2nd degree)
 - a. Apply cool (not ice cold) compresses using the cleanest available cloth article.
 - b. Do not break blisters, remove tissue, remove adhered particles of clothing, or apply salve or ointment.
 - c. Apply clean dry dressing if necessary.
 - d. Treat victim for shock as required.
 - e. Arrange transportation to a hospital as quickly as possible.
 - f. If arms or legs are affected keep them elevated.

CHAPTER 1

GENERAL DESCRIPTION

1.1 INTRODUCTION

The R.V.R. model URP are very compact externally powered FM exciters which may be used as an economic alternative to a low power exciter or as a portable unit.

1.2 ELECTRICAL DESCRIPTION

The URP is capable of either 10 watts or 2 watts with the power output being controlled by a switch on the front panel. The URP/2 model is capable of 2 watts only. Both units operate from an external power supply which must be regulated to ensure stability of the operating frequency. The supply voltage may be in the range of 12 VDC to 13.8 VDC. Power output will vary somewhat with the applied supply voltage.

1.3 SPECIFICATIONS

Please refer to Table A for the electrical specifications and Table B for the mechanical specifications.

TABLE A**ELECTRICAL SPECIFICATIONS**

DC Power Requirements (approx) at 10W (approx) at 2.5W	12-13.8V, 2.2A or 1.7A
Frequency Range	from 87.5 to 108MHz (other in request)
Frequency Range	direct from front panel in 100KHz increments-shift 50KHz
Frequency Stability	better than ± 500 Hz
Max Power Output	10W $\pm 10\%$ dependent on and portionate to supplied DC Volatge (12-13.8V allowed)
R.F. Output Connector	S0239 (PL) type
Output Impedance	50 Ohm
Audio Inputs	2 Total, 5KOhm impedance, unbalanced, balanced. 1 Standard stereo male XLR which can be used either for composite/wideband operation or monaural operation (switchable). 1 Standard mono male XLR for direct microphone use with built-in micro pre-amp and limiter.
Input Level for Stereo Version	2Vrms for 100% modulation
Input Level for Mono Version	25mV rms for 100% modulation

Stereo Separation	40dB or better
Amplitude Response 30Hz to	± 0.5 dB or better, 100KHz
Pre-emphasis	for FCC 75 microsec for CCIR 50 microsec
S/N Ratio	>70 dB below ± 75 KHz deviation at 400Hz measured in a 30Hz to 100KHz bandwidth with 75 μ sec
Spurious Harmonic Suppression	meets or exceeds all FCC and CCIR requirements
Modulation Capability	meets or exceeds all FCC and CCIR requirements (the following AM noise parameters are determined primarily by the DC power source used)
Asynchronous AM S/N Ratio	70dB below reference carrier with 100% amplitude modulation at 400Hz, without de-emphasis, no FM modulation present
Asynchronous AM S/N Ratio	60dB below reference carrier with 100% amplitude modulation at 400Hz, without de-emphasis, FM modulation = ± 75 KHz at 400Hz
THD, IMD, TIM	0.25% or better

TABLE B

DIMENSIONAL AND ENVIRONMENTAL SPECIFICATIONS

Chassis Dimensions	143mm (5.7") W 71mm (2.8") H 310mm (12.4") D
Ambient Operating Temperature	from -10°C to +45°C
Humidity	90% maximum, non-condensing
Weight	2 Kg (4.5 lbs)

CHAPTER 2

ELECTRICAL DESCRIPTION

2.1 FRONT PANEL BOARD

The front panel board contains all of the controls, switches and indicators necessary to operate the unit.

Toggle switches control DC power (9 Fig.1), RF power (3 Fig.1), Stereo /Mono selection (1 Fig.1), Line/Mike selection (2 Fig.1), and Power/Deviation selection.

The four digi-switches (5 Fig.1) control the frequency of the unit in 100KHz steps.

2.2 SYNTHESIZER BOARD

The Synthesizer board contains the phase lock loop circuits required to maintain the unit on frequency. IC1 is the reference frequency oscillator and divider.

The crystal oscillator oscillates at 6.4MHz and is divided down to 781.25Hz which is the reference input frequency to IC2 phase detector. The VCO frequency of 88 to 108MHz comes in to the board at CN7 to IC4 where it is divided by 128.

The VCO signal then goes to T2 and IC5. IC5 divides by a number determined by the front panel digi-switches. The output of this divider is 781.25Hz when the units is locked to the reference frequency.

When the unit is out of lock the phase detector generates an error signal which if filtered by IC3B and used to steer the VCO to the proper frequency.

IC3A generates the Mute signal which shuts down the RF output when the unit is unlocked, and lights the unlock light (12 Fig.1) on the front panel.

2.3 VCO/AUDIO BOARD

The VCO/Audio board generates an RF signal at the output frequency which is locked to a stable crystal reference as shown in 2.2.

The VCO is T4 and its associated circuits. The coil L1 is made up of coaxial cable to prevent microphonics in the output signal due to vibration of the oscillator components.

Diodes D2 and D4 are varicap diodes used to control the frequency of the VCO.

A DC control voltage from the synthesizer is used to control this point. Diodes D1 and D3 are used to modulate the VCO with the desired audio signal from the audio processing circuits.

T6 and T7 make up a set of gate controlled amplifiers. T9 controls the on/off condition the amplifier by application of the unlock control signal from the synthesizer.

The Audio section process the input audio signal for application to the

VCO.

IC8B amplifies the input signal. Jumper JP2 is used when the user desired single ended input.

With JP2 out of the circuit, the input is balanced. The output of IC8B is sent to IC8A. With capacitors C63 and C64 in the circuit, pre-emphasis is applied.

The insertion of these capacitors is controlled by the stereo/mono switch on the front panel. The output of IC8A is used to modulate the unit in the line selection.

In the microphone selection the signal from IC8B is further amplified in IC9B and IC9A. IC10A and IC10B are used to rectify the audio signal and process it for a deviation meter reading.

2.4 POWER AMPLIFIER BOARD

The power amplifier board receives the RF signal from the VCO board at a level of 1.5 to 2 watts.

In the URP this signal is amplified by Q1 to ten watt level with the high/low switch (4 Fig.1) on the front panel shorting out the collector/emitter junction of Q2. When the high/low switch is open, transistor Q2 lower the voltage to Q1 and thus lowers the output power.

The amplified signal is then sent through a low pass filter to remove the harmonic content, then sent to the VSWR circuit where the power is sampled for the front panel meter reading.

Only the direct power is measured on the front panel.

FRONT PANEL

VIEW DESCRIPTION (Fig. 1)

1	MONO/STEREO	Mono/Stereo switch
2	LINE/MIKE	Input type Swtitch : line or mike
3	DEV/PWR	The measurement made by the meter corresponds to the position of this selector (Deviation or Power Output)
4	HIGH/LOW	Level Power Output : High= 10W Low= 2W
5	FREQUENCY	Rotary frequency selector
6	+50	Led indicating the +50KHz shift insertion
7	AUDIO INPUT	Audio Input connector (XLRmale connector)
8	DEV ADJ	Deviation Adjustment trimmer
9	ON	Power On switch
10	ON	Power On led
11	PWR/DEV	Analog meter used to monitor the parameters of the exciter such as: DEVIATION POWER OUTPUT
12	UNLOCK	Indicated that the VCO is not locked to the reference frequency. The power will drop to zero in this condition

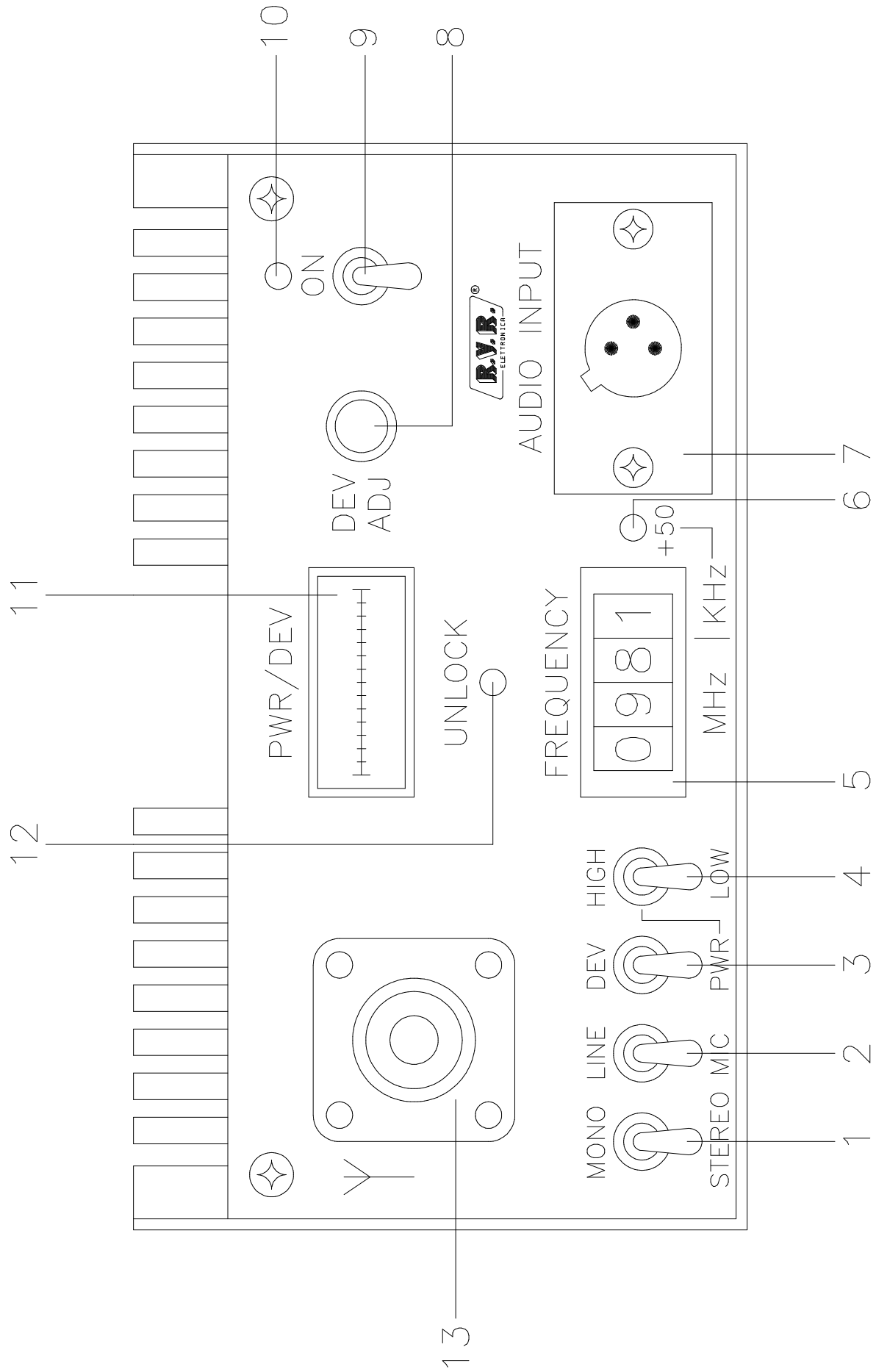

FRONT PANEL (FIG. 1)

REAR PANEL

VIEW DESCRIPTION (Fig. 2)

1	PWR ADJ	Trimmer to regulate the power output of the exciter
2	DC POWER INPUT	DC power input connector
3	FUSE	Fuse block. Fuse = 4A for the 10W version Fuse = 3.15A for the 2W version

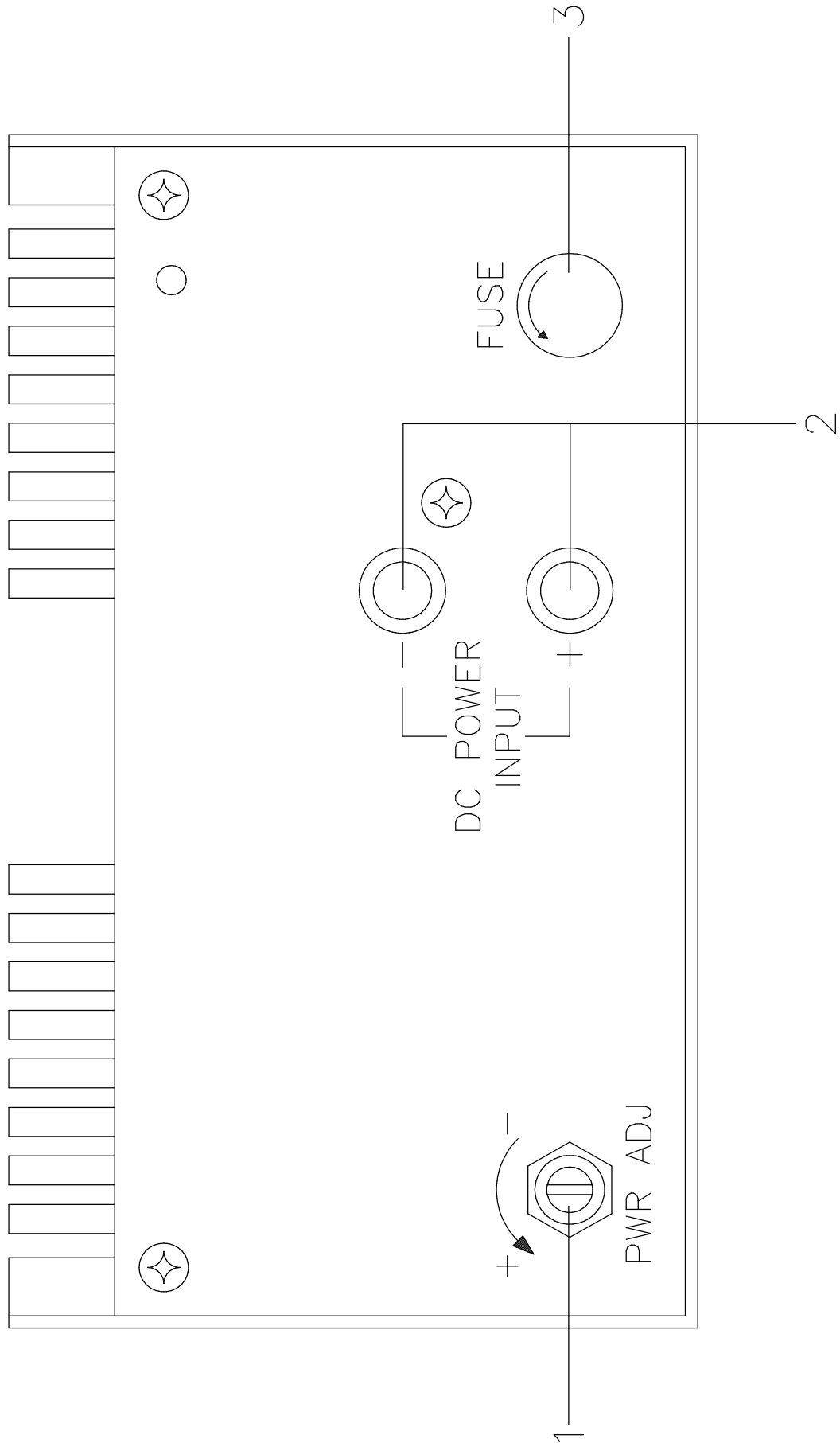

REAR PANEL (FIG.2)

CHAPTER 3

INSTALLATION PROCEDURE

3.1 INTRODUCTION

This chapter contains the information required to install the URP and carry out preliminary checks.

3.2 UNPACKING

Remove the unit from its packing and, before anything else, ensure that the unit has not suffered any damage during transit and that all front and rear panel controls are operational.

3.1 INSTALLATION

To install the URP exciter, carry out the following procedure:

- 1) Connect a suitable dummy load (50 ohm) to the antenna connector (13 Fig.1) or connect to the intended antenna (50 ohm).
The unit should be connected to the proper load to ensure that it does not generate unwanted spurs or get damage due to high VSWR caused by antenna or load mismatch.
Antenna VSWR should be 1.5:1 or better.
- 2) Set the desired operating frequency on the front panel digi-switches.
An additional 50KHz may be set with jumper JP1 on the synthesizer board.
- 3) Connect the audio line to the front panel.
The unit will accept either a line input of 0dBm or a microphone input of approx 20mV rms.
The desired input is selected with the Line/Mic switch (2 Fig.1) on the front panel.
This input will accept signals up to 100KHz. The user has the option of using either mono or a multiplex signal from stereo generator. The URP unit does not contain an internal stereo generator.
- 4) Connect 12 to 13.8 volts DC to the rear panel.
CAUTION : Observe the polarity of DC voltage.
Plus goes to the red terminal and minus goes to the black terminal. The URP units contain a reverse current diode to protect the unit against power reversal.
The purpose of this diode is to blow the fuse in the event of DC input reversal.
The fuse is 4A for the 10W version and 3.15A for the 2W version. The size of the wire should be sufficient to prevent voltage drop

on the wires or heating of the wires.

The power supply itself should be tightly regulated. The unit may also be powered from a suitable 12 volt battery or a battery charged by a solar panel.

For the mains voltage connections see as reference Fig.3

In each case the power source must be stable to prevent unlocking of the VCO or modulation of the signal by unstable power source.

- 5) Place the DEV/PWR switch (3 Fig.1) on the front panel to the power position.

Turn the power on to the unit. Observe that the power light (10 Fig.1) comes on and the unlock light (12 Fig.1) will go out and the power meter (11 Fig.1) will register power output.

The unit is designed to shut down the power if the phase lock loop is in the unlocked condition.

- 6) Place the DEV/PWR switch (3 Fig.1) in the DEV position and apply the modulation.

Check to ensure that the unit is not overmodulating.

Modulation level may be adjusted with the DEV ADJ control (8 Fig.1) on the front panel.

Use a small screwdriver blade to adjust the level.

- 7) For the audio input connections see as reference Fig.4

BATTERY CHARGER CONNECTOR

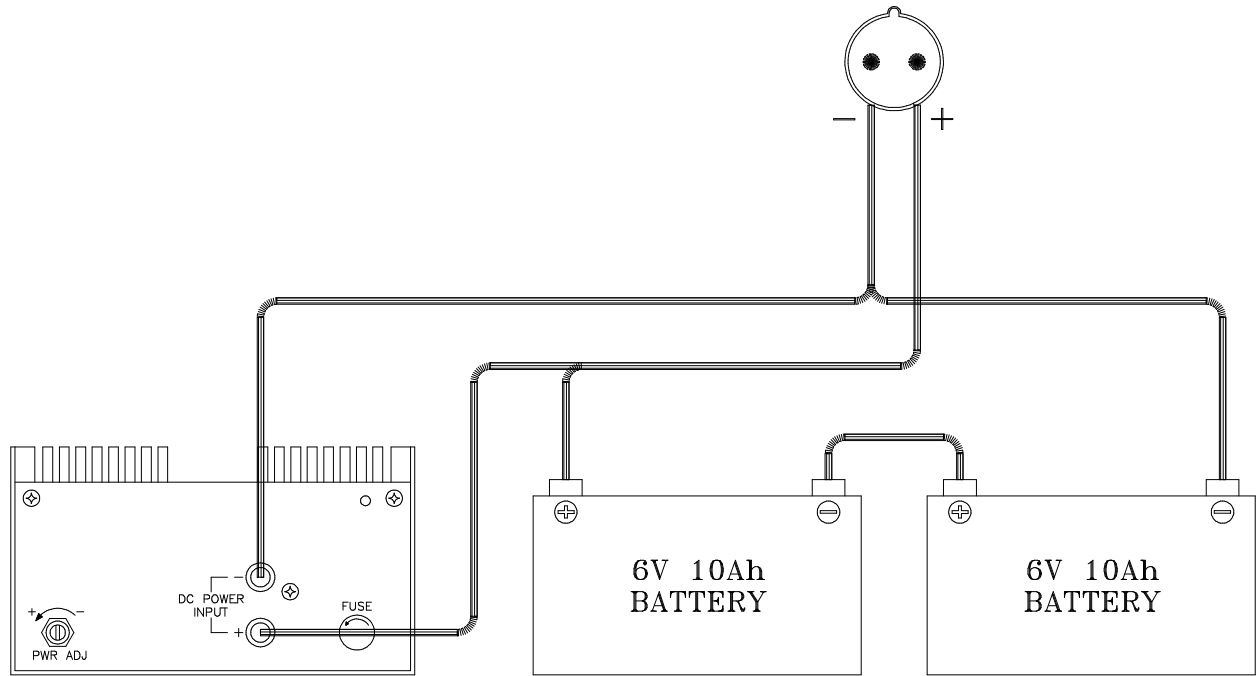

URP

ALIMENTATION WITH BATTERY

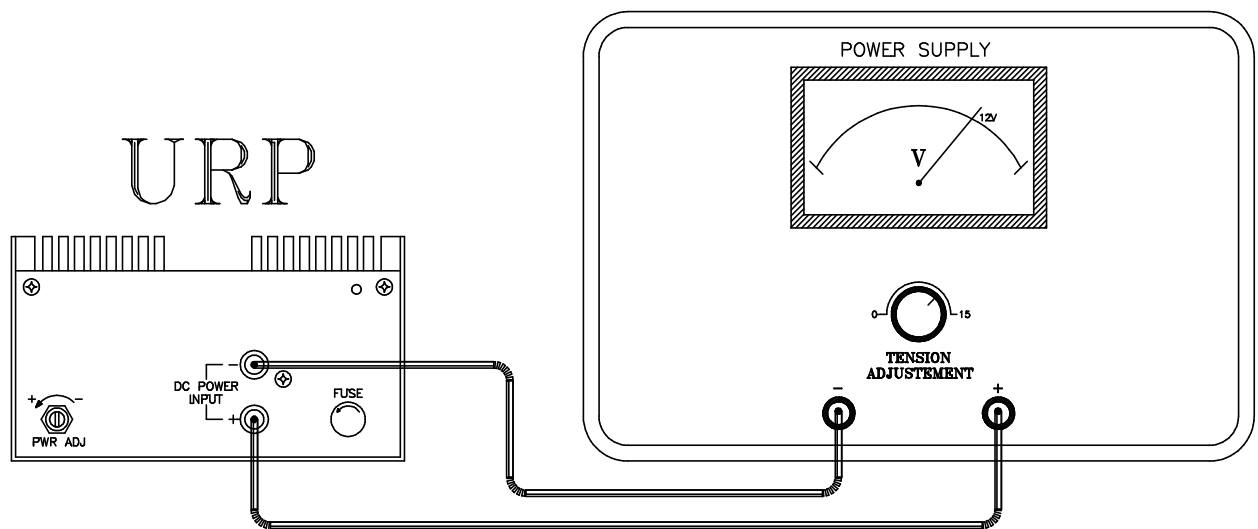

URP

ALIMENTATION WITH POWER SUPPLY

MAIN VOLTAGE CONNECTIONS (FIG.3)

CONNECTIONS TO OBTAIN THE BALANCED AUDIO INPUT

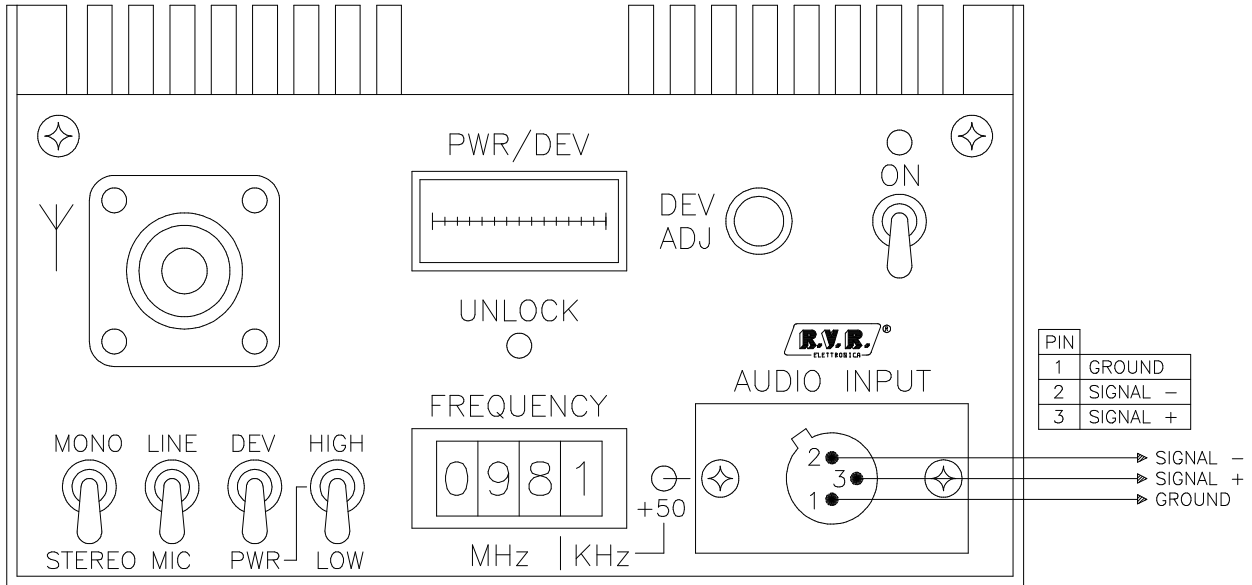

CONNECTIONS TO OBTAIN THE UNBALANCED AUDIO INPUT

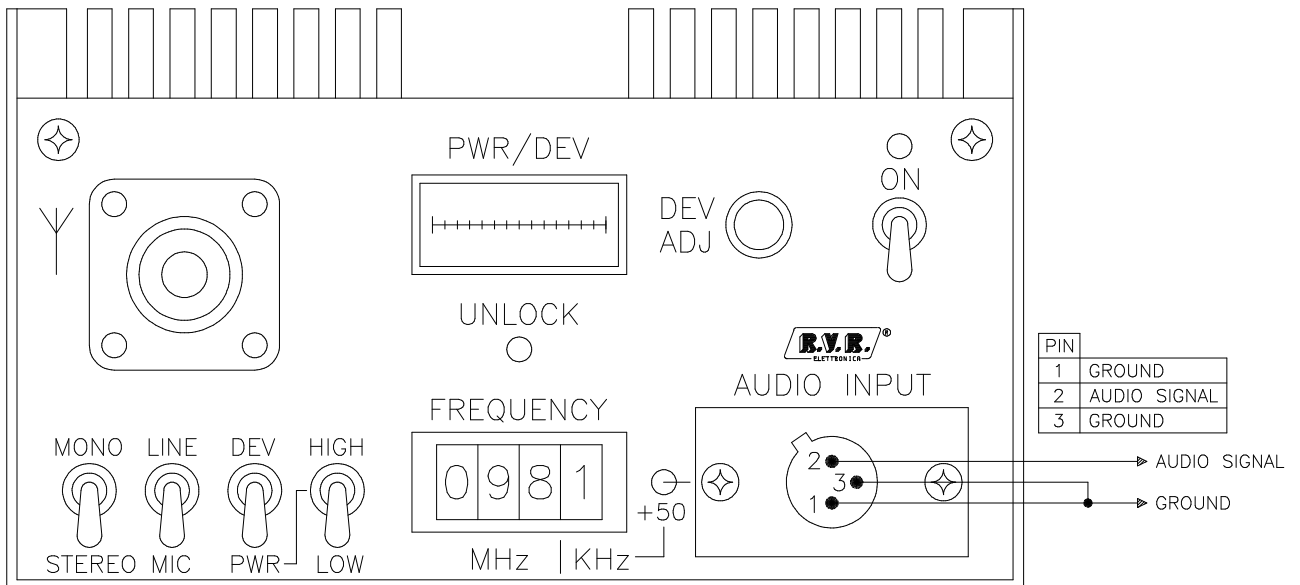

AUDIO INPUT CONNECTIONS (FIG. 4)

APPENDIX A

CIRCUIT DIAGRAMS, LAYOUTS AND BILLS OF MATERIAL

This section contains circuit diagrams, layouts and bills of material of the modules which composing the equipment.
For more information about each module see as reference Section 2.

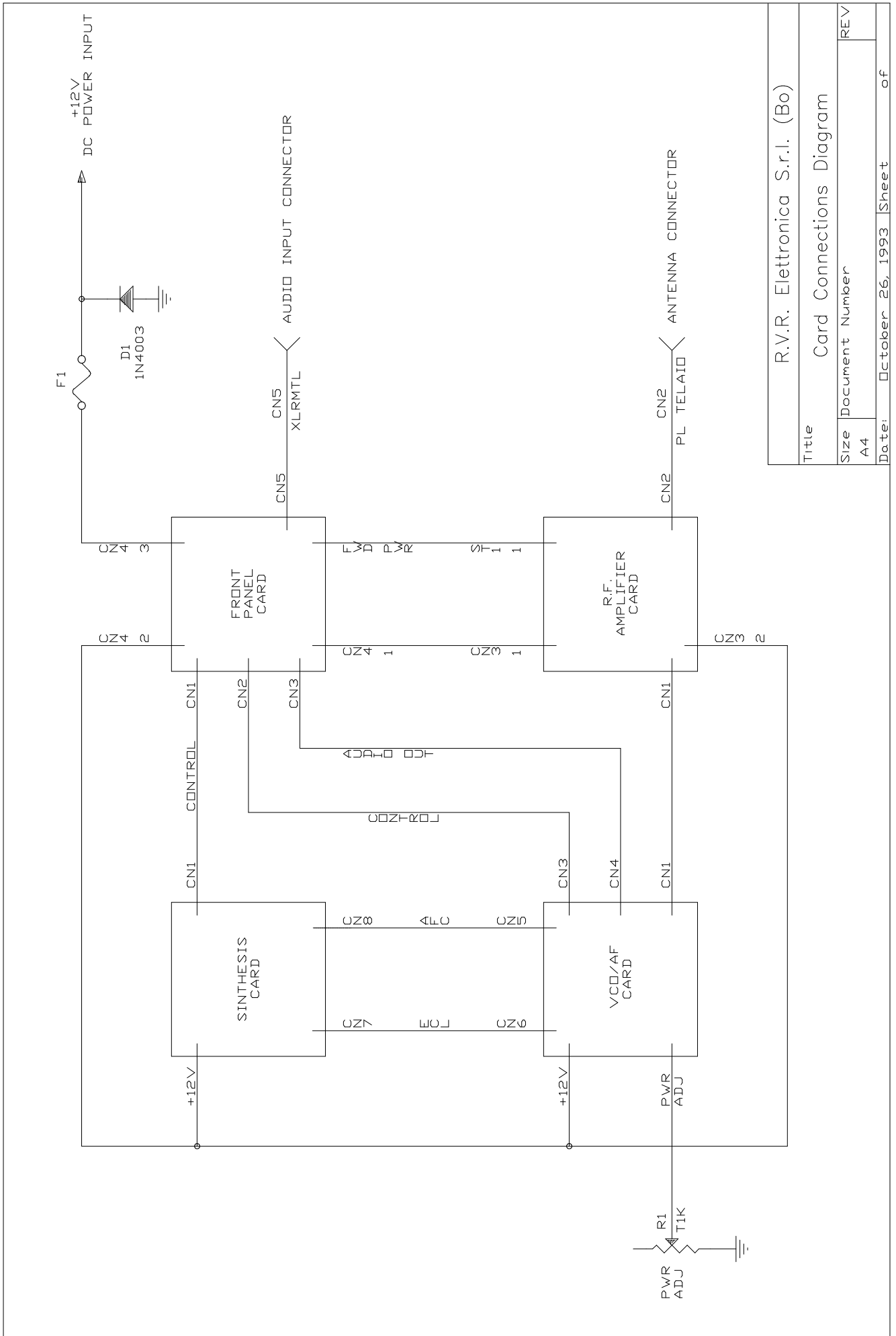

Title		R.V.R. Elettronica S.r.l. (Bo)
Size		Card Connections Diagram
Document Number	REV	
A4		
Date:	October 26, 1993	Sheet of

FRONT PANEL CARD

1	<i>Circuit Diagram</i>	<i>Pag</i>	26
2	<i>Bill of Materials</i>	<i>Pag</i>	27
3	<i>Component Layout</i>	<i>Pag</i>	28

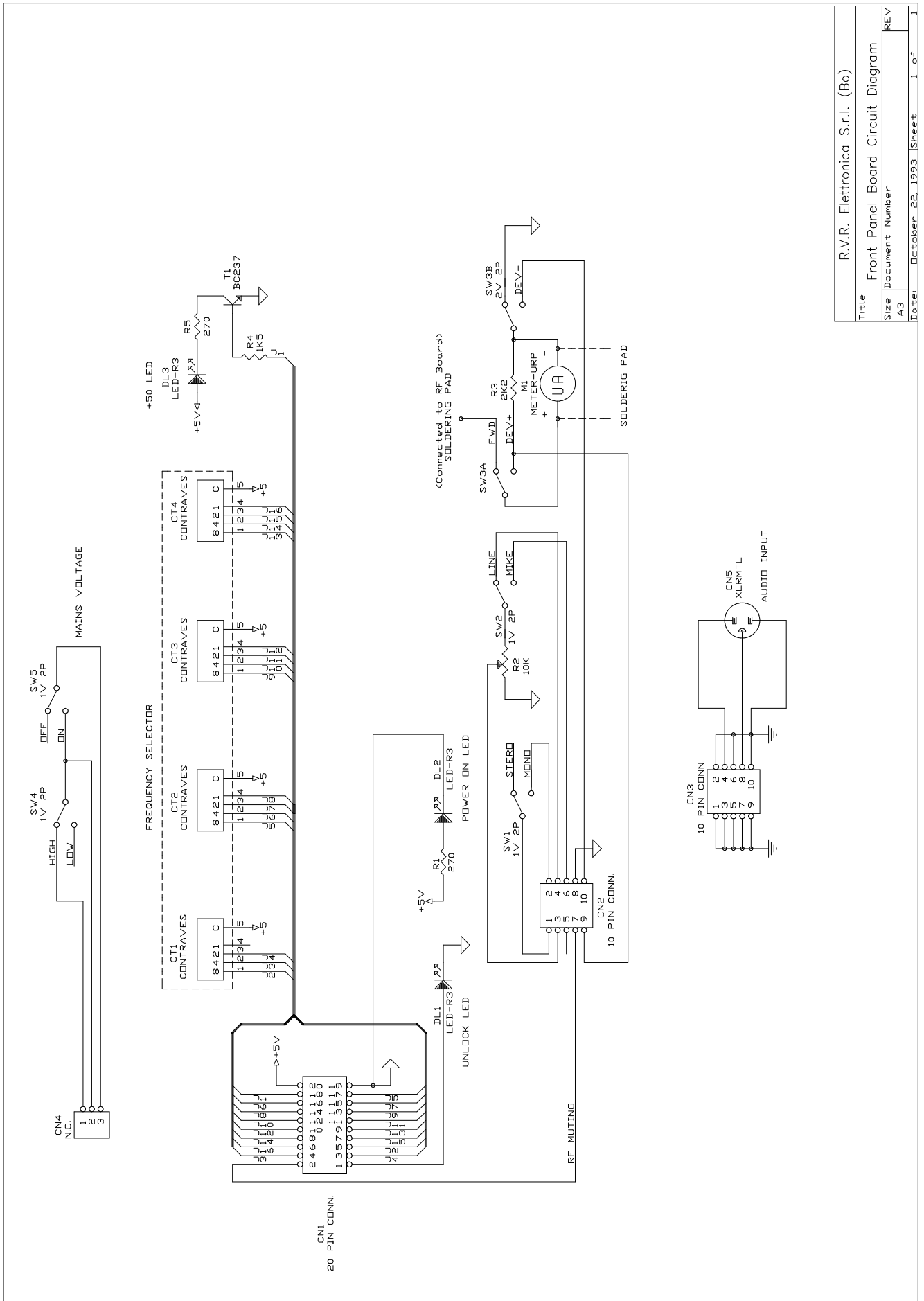

R.V.R. Elettronica S.r.l. (Bo)

Title	Front Panel Board Circuit Diagram
Size	A3
Document Number	REV
Date:	October 22, 1993
Sheet	1 of 1

<i>Front Panel Card</i>			<i>Bill of Materials/Lista Componenti</i>		<i>Pag. 1</i>
<i>Item</i>	<i>Quantity</i>	<i>Reference</i>	<i>Part</i>	<i>Description</i>	<i>Part Order Code</i>
1	2	R1,R5	270	RESISTOR 1/4W 5%	RSC1/4JH0270
2	1	R4	1K5	RESISTOR 1/4W 5%	RSC1/4JK01,5
3	1	R3	2K2	RESISTOR 1/4W 5%	RSC1/4JK02,2
4	1	R2	10K	RESISTOR 1/4W 5%	RSC1/4JK0010
5	1	M1	METER-URP	STRUMENTO ORIZ. URM	SMASK15
6	1	CN5	XLRMTL	XLR MASCHIO DA TELAIO	CNTXLRMP3P
7	2	CN2,CN3	10P CONN.	CONN. M 2*5 P 2.54	CNTMCSFC10P
8	1	CN1	20P CONN.	CONN. M 2*10 P 2.54	CNTMCSFC20P
9	4	SW1,SW2, SW4,SW5	1V 2P	DEVIATORE 1 VIA 2 POS	DEV1V1103CS
10	1	SW3	2V 2P	DEVIATORE 2 VIE 2 POS	DEV2V1103CS
11	4	CT1,CT2, CT3,CT4	CONTRAVES	COMMUTATORI BCD 15mm	COMBCD15
12	3	DL1,DL2,DL3	LED-R3	RED LED DIODE 3mm	LEDRO03
13	1	T1	BC237	NPN TRANSISTOR	TRNBC237
14	1	CN4	N.C.	NOT CONNECTED	

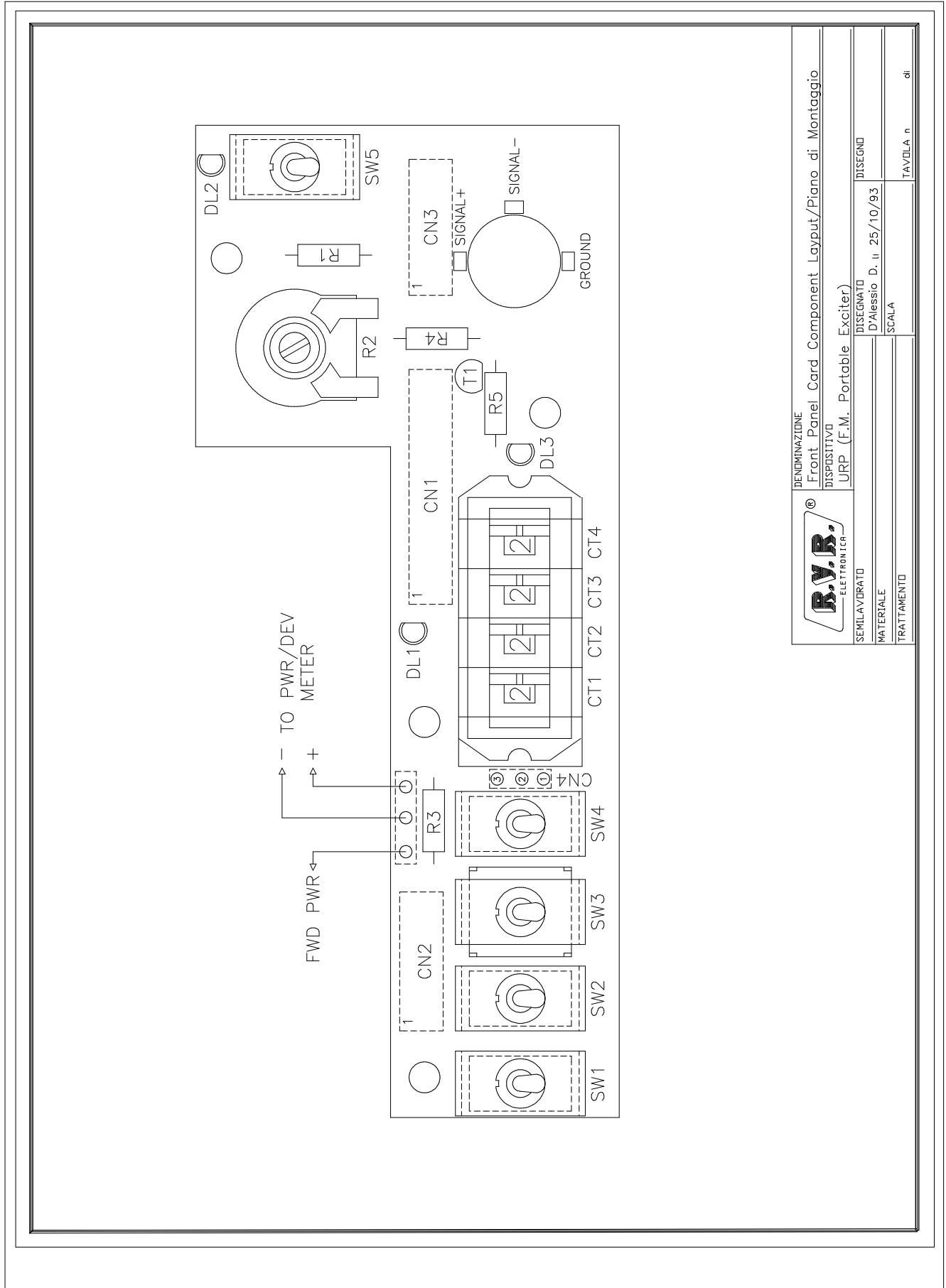

	
DENOMINAZIONE Front Panel Card Component Layout/Piano di Montaggio	
DISPOSITIVO URP (F.M. Portable Exciter)	
SEMILAVORATO	DISEGNATO D'Alessio D. II 25/10/93
MATERIALE	SCALA
TRATTAMENTO	TAVOLA n. di

SYNTHESIS CARD

1	<i>Circuit Diagram</i>	<i>Pag</i>	30
2	<i>Bill of Materials</i>	<i>Pag</i>	31
3	<i>Component Layout</i>	<i>Pag</i>	33

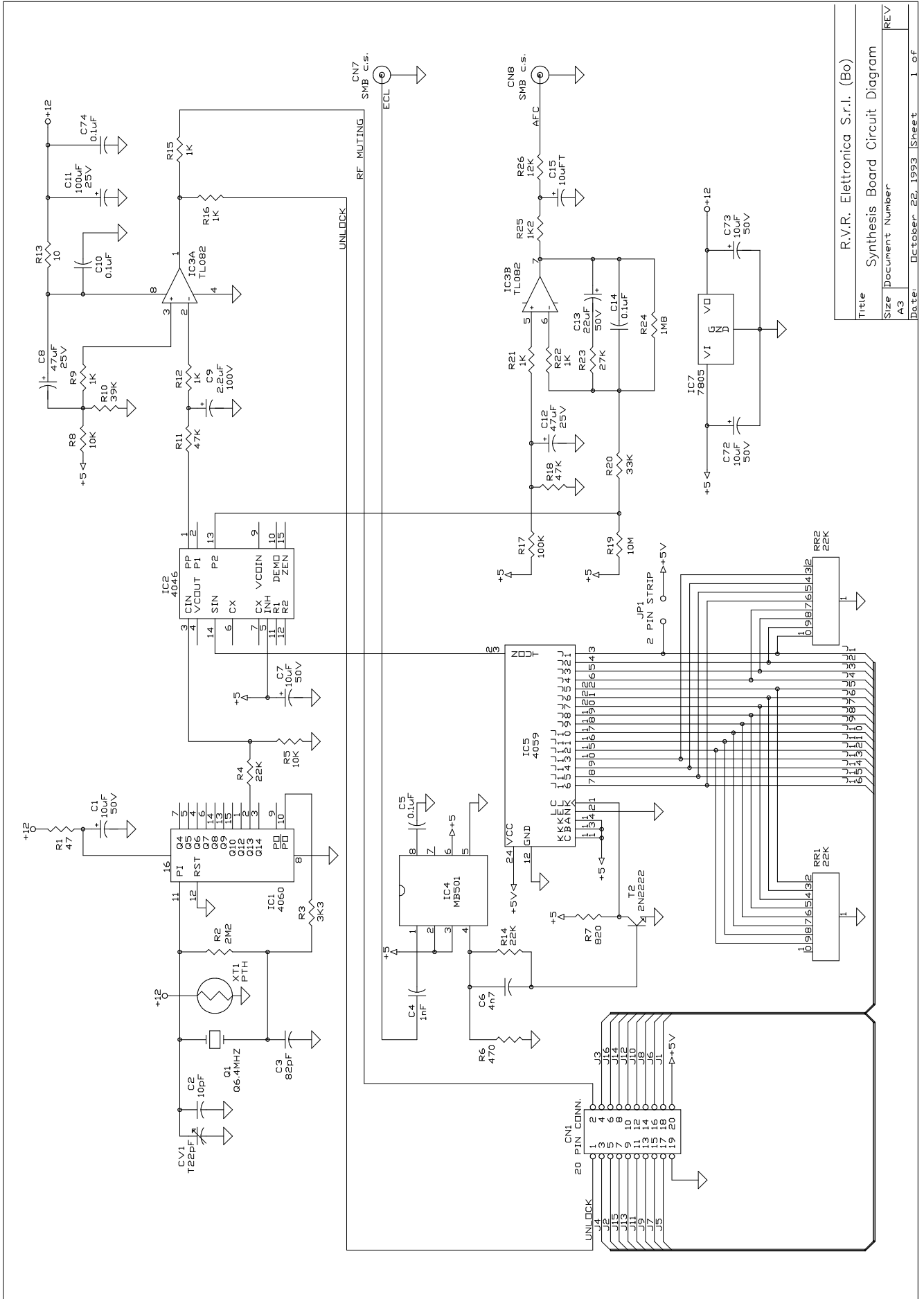

R.V.R. Elettronica S.r.l. (Bo)	
Title	Synthesis Board Circuit Diagram
Size	Document Number
A3	REV
Date:	October 22, 1993 Sheet 1 of 1

Synthesis Card			Bill of Materials/Lista Componenti		Pag. 1
Item	Quantity	Reference	Part	Description	Part Order Code
1	1	R13	10	RESISTOR 1/4W 5%	RSC1/4JH0010
2	1	R1	47	RESISTOR 1/4W 5%	RSC1/4JH0047
3	1	R6	470	RESISTOR 1/4W 5%	RSC1/4JH0470
4	1	R7	820	RESISTOR 1/4W 5%	RSC1/4JH0820
5	6	R9,R12,R15, R16,R21,R22	1K	RESISTOR 1/4W 5%	RSC1/4JK0001
6	1	R25	1K2	RESISTOR 1/4W 5%	RSC1/4JK01,2
7	1	R3	3K3	RESISTOR 1/4W 5%	RSC1/4JK03,3
8	2	R5,R8	10K	RESISTOR 1/4W 5%	RSC1/4JK0010
9	1	R26	12K	RESISTOR 1/4W 5%	RSC1/4JK0012
10	4	RR1,RR2, R4,R14	22K	RESISTOR 1/4W 5%	RSC1/4JK0022
11	1	R23	27K	RESISTOR 1/4W 5%	RSC1/4JK0027
12	1	R20	33K	RESISTOR 1/4W 5%	RSC1/4JK0033
13	1	R10	39K	RESISTOR 1/4W 5%	RSC1/4JK0039
14	2	R11,R18	47K	RESISTOR 1/4W 5%	RSC1/4JK0047
15	1	R17	100K	RESISTOR 1/4W 5%	RSC1/4JK0100
16	1	R24	1M8	RESISTOR 1/4W 5%	RSC1/4JM01,8
17	1	R2	2M2	RESISTOR 1/4W 5%	RSC1/4JM02,2
18	1	R19	10M	RESISTOR 1/4W 5%	RSC1/4JM0010
19	1	C2	10pF	CERAMIC CAPACITOR NP0	CKM100BJ600C
20	1	CV1	T22pF	TRIMMER CAPACITOR	CVF220CK600
21	1	C3	82pF	CERAMIC CAPACITOR NP0	CKM820BJ600C
22	1	C4	1nF	CERAMIC CAPACITOR	CKM102BK600P
23	1	C6	4n7	CERAMIC CAPACITOR	CKM472BK600P
24	4	C5,C10, C14,C74	0.1µF	CERAMIC CAPACITOR	CKM104BK600P
25	1	C9	2.2µF	ELECTROLYTIC CAPACITOR	CEA225AM630
26	4	C1,C7,C72, C73	10µF	ELECTROLYTIC CAPACITOR	CEA106AM350
27	1	C15	10µFT	TANTALIUM CAPACITOR	CET106AM350

Synthesis Card			Bill of Materials/Lista Componenti		Pag. 2
Item	Quantity	Reference	Part	Description	Part Order Code
28	1	C13	22 μ F	ELECTROLYTIC CAPACITOR	CEA226BM350
29	2	C8,C12	47 μ F	ELECTROLYTIC CAPACITOR	CEA476BM630
30	1	C11	100 μ F	ELECTROLYTIC CAPACITOR	CEA107BM350
31	1	JP1	2 PIN STRIP	STRIP M P 2.54 2 PIN	CNTSTRIPMCS
32	1	CN1	20P CONN.	CONN. M 2*10 P 2.54	CNTMCSFC20P
33	2	CN7,CN8	SMB C.S.	CONN. SMB A STAMPATO	CNTSMBMCS
34	1	XT1	PTH	CRYSTAL HEATER	PTHHC18
35	1	Q1	Q6.4MHZ	CRYSTAL	QRZ6.4HC18
36	1	IC7	7805	POS. STABILIZER 1A	CIL7805P
37	1	T2	2N2222	NPN RF TRANSISTOR	TRN2N2222
38	1	IC3	TL082	DOUBLE OP. AMP.	CILTL082
39	1	IC4	MB501	DUAL MOD. PRESCALER	CIDMB501
40	1	IC2	4046	CMOS PHASE COMPARATOR	CID4046
41	1	IC5	4059	CMOS PROGRAM. DIVIDER	CID4059
42	1	IC1	4060	CMOS BIN DIVIDER	CID4060

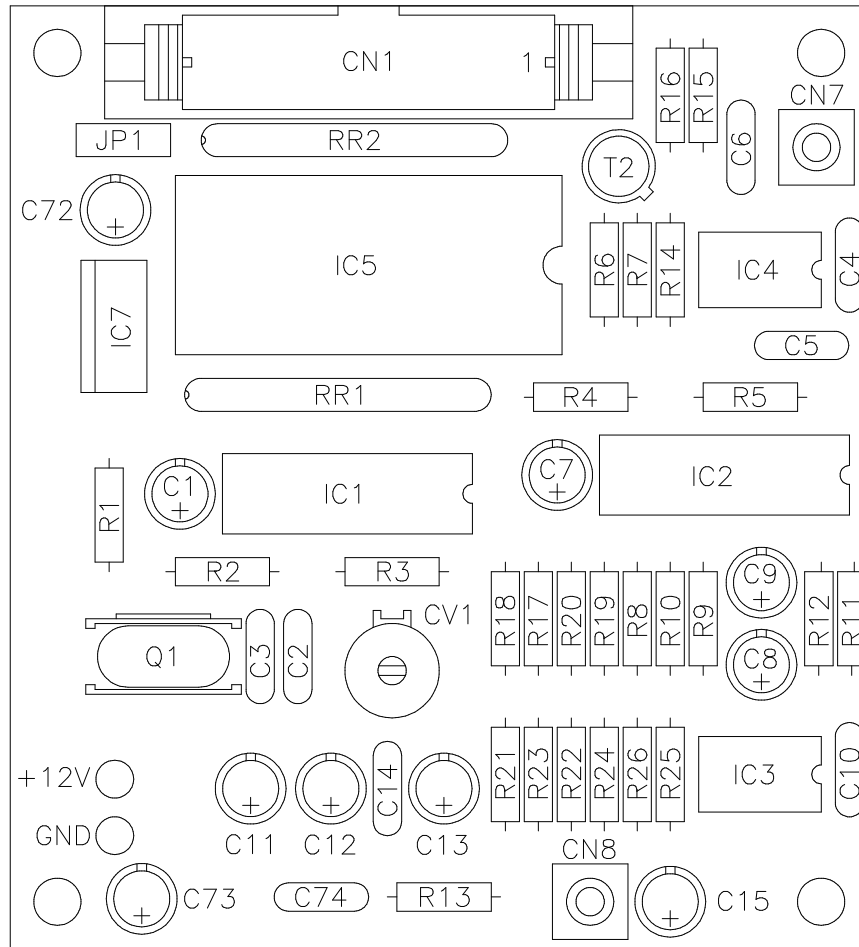

	DENOMINAZIONE Synthesis Card Component Layout / Piano di Montaggio	
	DISPOSITIVO URP (FM Portable Exciter)	
SEMILAVORATO	DISEGNATO D'Alessio D. U.	DISEGNO
MATERIALE	SCALA	
TRATTAMENTO		

R.F. AMPLIFIER CARD

1	<i>Circuit Diagram</i>	<i>Pag</i>	35
2	<i>Bill of Materials</i>	<i>Pag</i>	36
3	<i>Component Layout</i>	<i>Pag</i>	38

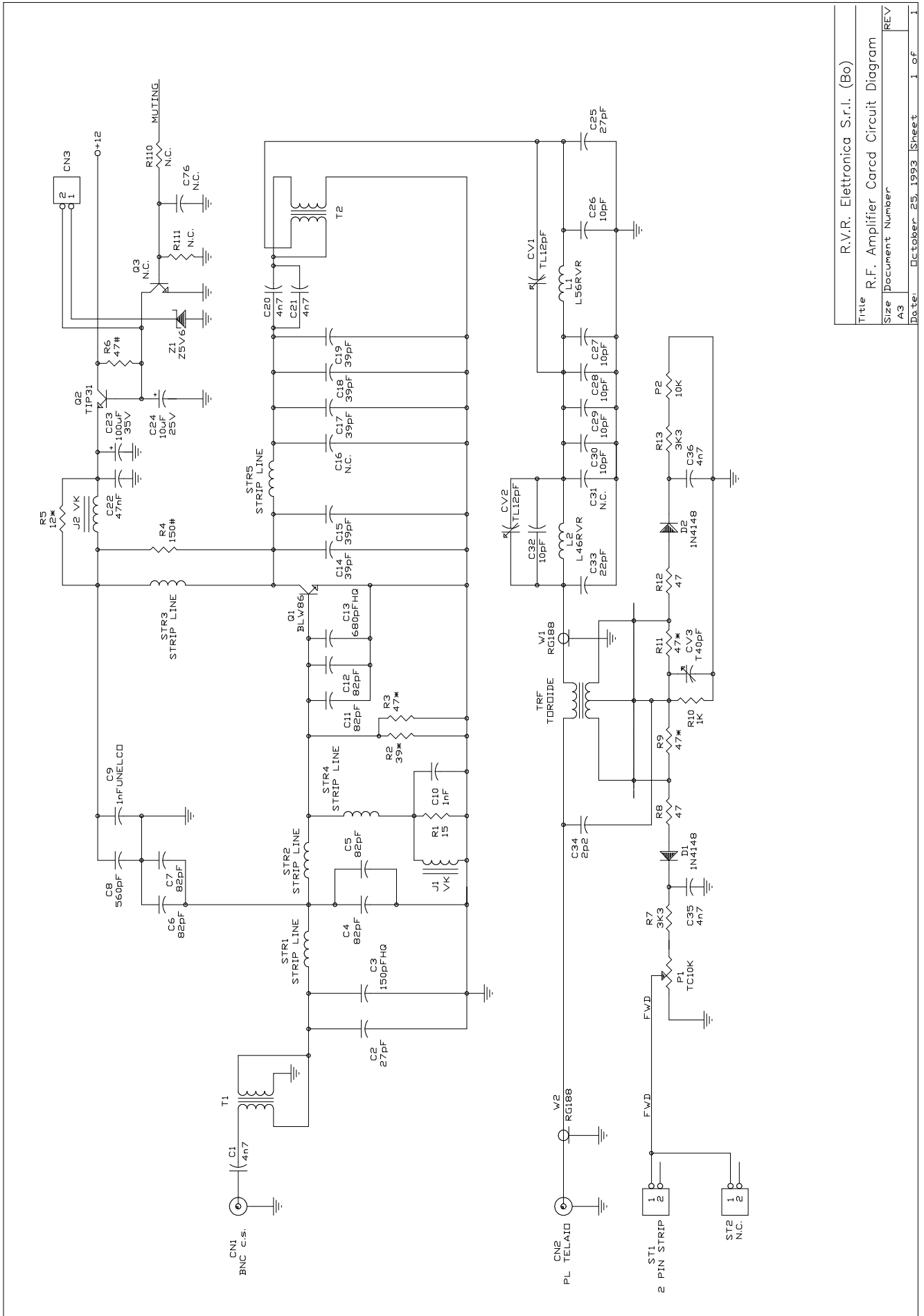



Title		R.V.R. Elettronica S.r.l. (Bo)
Size		Document Number
A3	REV	
Date:	October 25, 1993	Sheet 1 of 1

Item	Quantity	Reference	Part	Description	Part Order Code
1	1	R5	12*	RESISTOR 1/2W 5%	RSC1/2JH0012
2	1	R1	15	RESISTOR 1/4W 5%	RSC1/4JH0015
3	1	R2	39*	RESISTOR 1/2W 5%	RSC1/2JH0039
4	2	R8,R12	47	RESISTOR 1/4W 5%	RSC1/4JH0047
5	3	R3,R9,R11	47*	RESISTOR 1/2W 5%	RSC1/2JH0047
6	1	R6	47#	RESISTOR 2W	RSC002JH0047
7	1	R4	150#	RESISTOR 2W	RSC002JH0150
8	1	R10	1K	RESISTOR 1/4W 5%	RSC1/4JK0001
9	2	R7,R13	3K3	RESISTOR 1/4W 5%	RSC1/4JK03,3
10	1	P2	10K	RESISTOR 1/4W 5%	RSC1/4JK0010
11	1	P1	TC10K	TRIM. REG. VERT. CERMET	RVTCERVK0010
12	1	C34	2p2	CERAMIC CAPACITOR NP0	CKM2,2BJ600C
13	6	C26,C27, C28,C29, C30,C32	10pF	CERAMIC CAPACITOR NP0	CKM100BJ600C
14	2	CV1,CV2	TL12pF	TRIMMER CAPACITOR	CVC120DK600
15	1	C33	22pF	CERAMIC CAPACITOR NP0	CKM220BJ600C
16	2	C2,C25	27pF	CERAMIC CAPACITOR NP0	CKM270BJ600C
17	5	C14,C15, C17,C18,C19	39pF	CERAMIC CAPACITOR NP0	CKM390BJ600C
18	1	CV3	T40pF	TRIMMER CAPACITOR	CVF400BK
19	6	C4,C5,C6, C7,C11,C12	82pF	CERAMIC CAPACITOR NP0	CKM820BJ600C
20	1	C3	150pFHQ	HIGHT Q CAPACITOR	CHQ151AJ500
21	1	C8	560pF	CERAMIC CAPACITOR	CKM561BK600P
22	1	C13	680pFHQ	HIGHT Q CAPACITOR	CHQ681AJ500
23	1	C10	1nF	CERAMIC CAPACITOR	CKM102BK600P
24	1	C9	1nFUNELCO	SILVER MICA CAPACITOR	CSM102XK351
25	5	C1,C20, C21,C35,C36	4n7	CERAMIC CAPACITOR	CKM472BK600P
26	1	C22	47nF	CERAMIC CAPACITOR	CKM473BK600P

R.F. Amplifier Card Bill of Materials/Lista Componenti Pag. 2

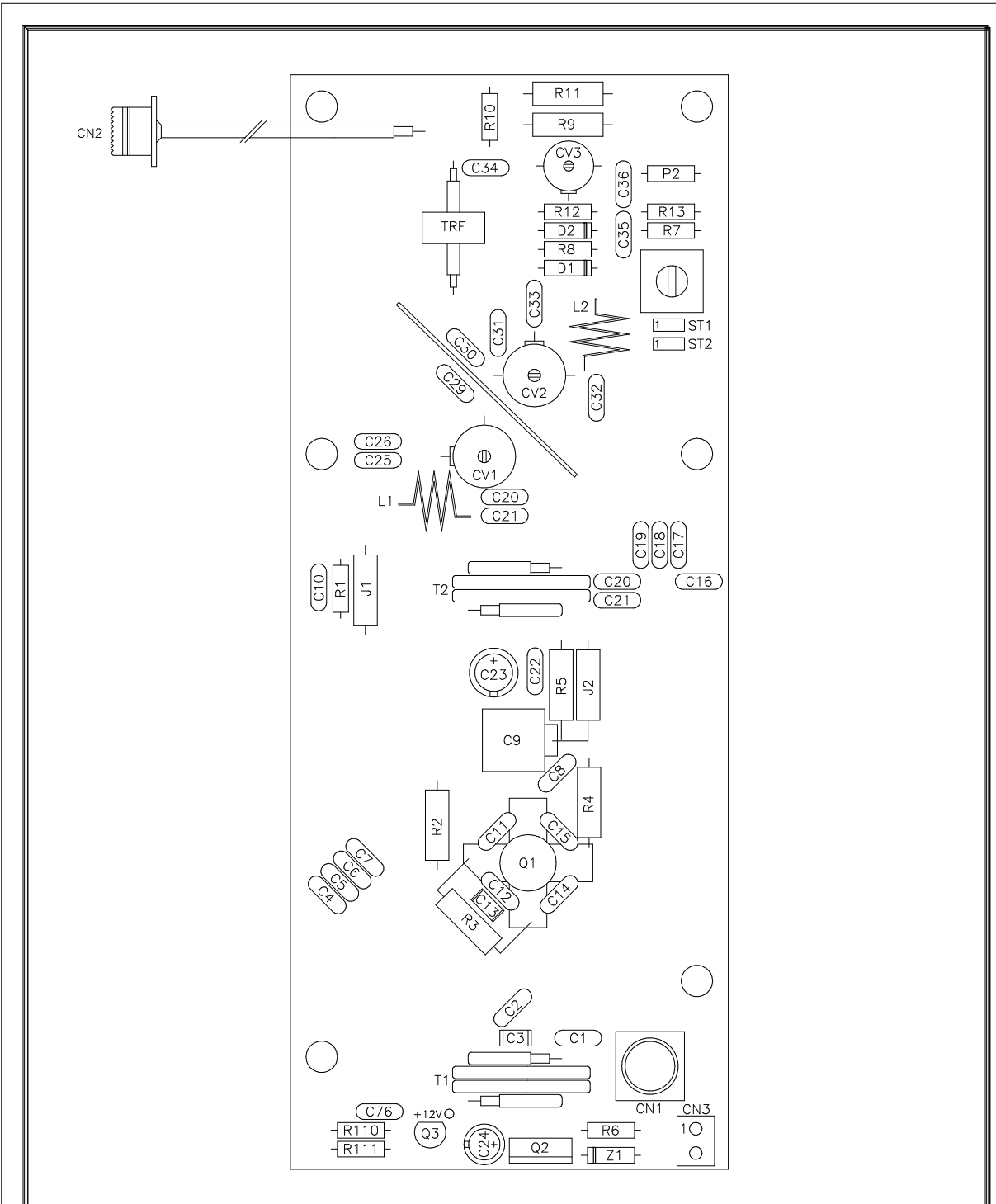
Item	Quantity	Reference	Part	Description	Part Order Code
27	1	C24	10 μ F	ELECTROLYTIC CAPACITOR	CEA106AM350
28	1	C23	100 μ F	ELECTROLYTIC CAPACITOR	CEA107BM350
29	2	J1,J2	VK	RF CHOKE	IMPVK00A
30	1	L2	L46RVR	4 SP DIA 6	
31	1	L1	L56RVR	5 SP DIA 6	
32	2	T1,T2	4:1	TRASF. RF. CAVO 25 OHM	CAV7612/78
33	1	TRF	TOROIDE	TOROIDE DIA. 10 MM	FTR10N
34	1	ST1	2 PIN STRIP	STRIP M P 2.54 2 PIN	CNTSTRIPMCS
35	2	W1,W2	RG188	COAX CABLE RG188	CAVRG188
36	1	CN1	BNC C.S.	CONN. BNC A STAMPATO	CNTBNCFCSO
37	1	CN2	PL TELAIO	CONN. PL A TELAIO	CNTPLFPFL
38	2	D1,D2	1N4148	SILICON DIODE	DIS1N4148
39	1	Z1	Z5V6	ZENER DIODE 5.6V 0.4W	DIZ5V60W4
40	1	Q2	TIP31	NPN DARLINGTON	TRNTIP31
41	1	Q1	BLW86	RF POWER TRANSISTOR	TRNBLW86
42	8	ST2,Q3,CN3, C16,C31, C76,R110, R111	N.C.	NOT CONNECTED	
43	5	STR1,STR2, STR3,STR4, STR5	STRIP LINE	STRIP LINE	



	DENOMINAZIONE		
	R.F. Amplifier Card Circuit Diagram/Piano di Montaggio		
DISPOSITIVO			
URP (Portable F.M. Exciter)			
SEMILAVORATO	DISEGNATO		DISEGNO
MATERIALE	D'Alessio D. tt 25/10/93		
TRATTAMENTO	SCALA		TAVOLA n di

VCO/AF CARD

1	<i>Circuit Diagram</i>	<i>Pag</i>	40
2	<i>Bill of Materials</i>	<i>Pag</i>	41
3	<i>Component Layout</i>	<i>Pag</i>	45

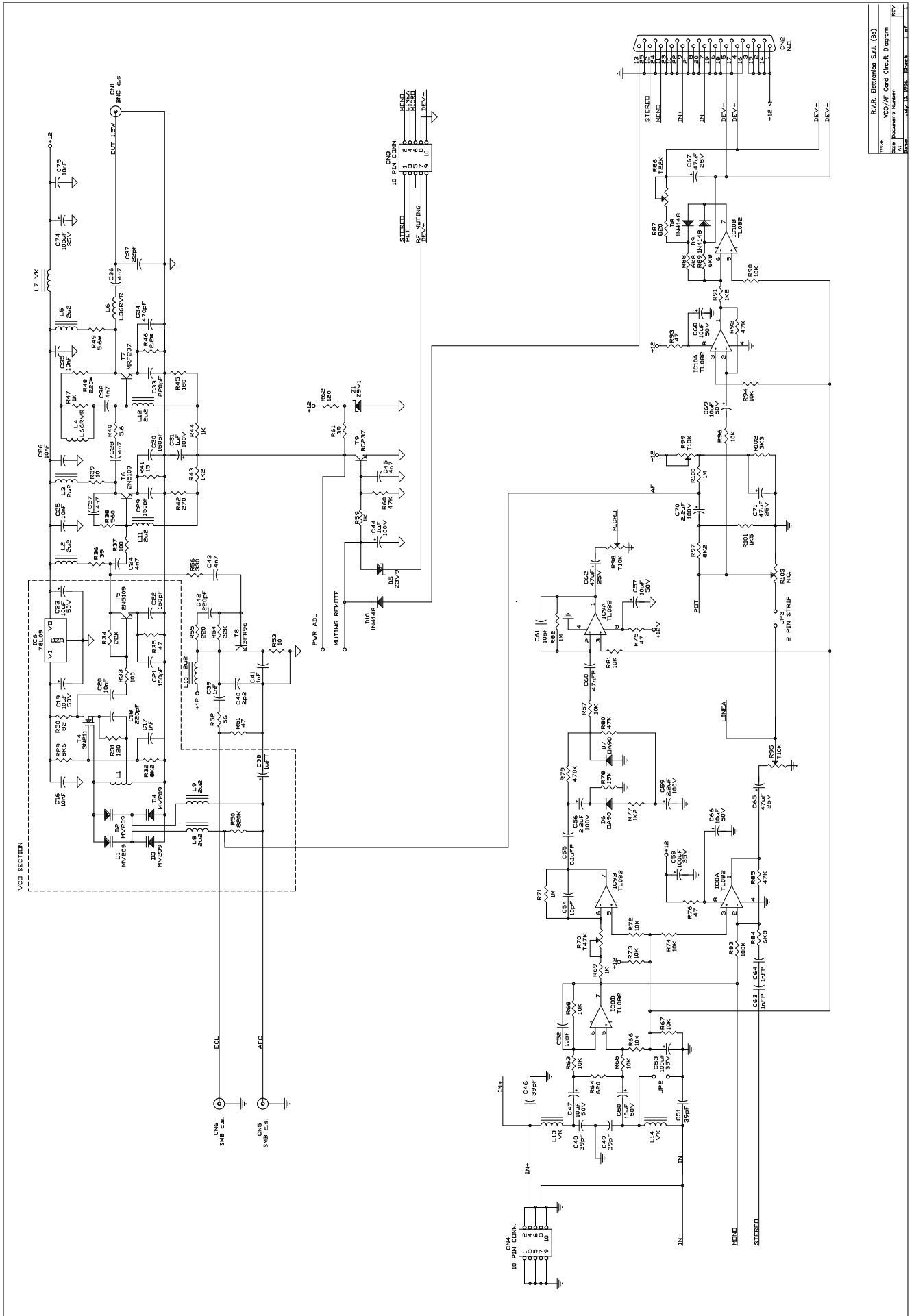

File	R.V.R. Elettronica S.r.l. (Bo)
Doc. Name	VCO/AF Core Circuit Diagram
Doc. Number	
Doc. Date	1997.08.18
Doc. Author	BOBBI
Doc. Rev.	01

VCO/AF Card			Bill of Materials/Lista Componenti		Pag. 1
Item	Quantity	Reference	Part	Description	Part Order Code
1	1	R46	2.2*	RESISTOR 1/2W 5%	RSC1/2JH02,2
2	1	R40	5.6	RESISTOR 1/4W 5%	RSC1/4JH05,6
3	1	R49	5.6*	RESISTOR 1/2W 5%	RSC1/2JH05,6
4	2	R39,R53	10	RESISTOR 1/4W 5%	RSC1/4JH0010
5	1	R41	15	RESISTOR 1/4W 5%	RSC1/4JH0015
6	2	R36,R61	39	RESISTOR 1/4W 5%	RSC1/4JH0039
7	5	R35,R51, R75,R76,R93	47	RESISTOR 1/4W 5%	RSC1/4JH0047
8	1	R52	56	RESISTOR 1/4W 5%	RSC1/4JH0056
9	1	R30	82	RESISTOR 1/4W 5%	RSC1/4JH0082
10	2	R33,R37	100	RESISTOR 1/4W 5%	RSC1/4JH0100
11	2	R31,R62	120	RESISTOR 1/4W 5%	RSC1/4JH0120
12	1	R45	180	RESISTOR 1/4W 5%	RSC1/4JH0180
13	1	R55	220	RESISTOR 1/4W 5%	RSC1/4JH0220
14	1	R48	220*	RESISTOR 1/2W 5%	RSC1/2JH0220
15	1	R42	270	RESISTOR 1/4W 5%	RSC1/4JH0270
16	1	R56	330	RESISTOR 1/4W 5%	RSC1/4JH0330
17	1	R38	560	RESISTOR 1/4W 5%	RSC1/4JH0560
18	1	R64	620	RESISTOR 1/4W 1%	RSM1/4FH0620
19	1	R87	820	RESISTOR 1/4W 5%	RSC1/4JH0820
20	4	R44,R47, R59,R69	1K	RESISTOR 1/4W 5%	RSC1/4JK0001
21	3	R43,R77,R91	1K2	RESISTOR 1/4W 5%	RSC1/4JK01,2
22	1	R101	1K5	RESISTOR 1/4W 5%	RSC1/4JK01,5
23	1	R102	3K3	RESISTOR 1/4W 5%	RSC1/4JK03,3
24	1	R29	5K6	RESISTOR 1/4W 5%	RSC1/4JK05,6
25	3	R84,R88,R89	6K8	RESISTOR 1/4W 5%	RSC1/4JK06,8
26	2	R32,R97	8K2	RESISTOR 1/4W 5%	RSC1/4JK08,2
27	4	R60,R80, R85,R92	47K	RESISTOR 1/4W 5%	RSC1/4JK0047

Item	Quantity	Reference	Part	Description	Part Order Code
28	13	R57,R63, R65,R66, R67,R68, R72,R73, R74,R81, R90,R94, R96	10K	RESISTOR 1/4W 5%	RSC1/4JK0010
29	1	R78	15K	RESISTOR 1/4W 5%	RSC1/4JK0015
30	2	R34,R54	22K	RESISTOR 1/4W 5%	RSC1/4JK0022
31	1	R83	100K	RESISTOR 1/4W 5%	RSC1/4JK0100
32	1	R79	470K	RESISTOR 1/4W 5%	RSC1/4JK0470
33	1	R50	820K	RESISTOR 1/4W 5%	RSC1/4JK0820
34	3	R71,R82, R100	1M	RESISTOR 1/4W 5%	RSC1/4JM0001
35	3	R95,R98,R99	T10K	TRIMMER REG. VERT. 10mm	RVTD10VK0010
36	1	R86	T22K	TRIMMER REG. VERT. 10mm	RVTD10VK0022
37	1	R70	T47K	TRIMMER REG. VERT. 10mm	RVTD10VK0047
38	1	C40	2p2	CERAMIC CAPACITOR NP0	CKM2,2BJ600C
39	3	C52,C54,C61	10pF	CERAMIC CAPACITOR NP0	CKM100BJ600C
40	1	C37	22pF	CERAMIC CAPACITOR NP0	CKM220BJ600C
41	4	C46,C48, C49,C51	39pF	CERAMIC CAPACITOR NP0	CKM390BJ600C
42	4	C21,C22, C29,C30	150pF	CERAMIC CAPACITOR NP0	CKM151BK600C
43	3	C18,C33,C42	220pF	CERAMIC CAPACITOR NP0	CKM221BK600C
44	1	C34	470pF	CERAMIC CAPACITOR	CKM471BK600P
45	3	C17,C39,C41	1nF	CERAMIC CAPACITOR	CKM102BK600P
46	2	C63,C64	1nFP	POLIESTER CAPACITOR	CPE102BK161
47	7	C24,C27, C28,C32, C36,C43, C45	4n7	CERAMIC CAPACITOR	CKM472BK600P
48	6	C16,C20, C25,C26, C35,C75	10nF	CERAMIC CAPACITOR	CKM103BK600P
49	1	C60	47nFP	POLIESTER CAPACITOR	CPE473BJ101

VCO/AF Card			Bill of Materials/Lista Componenti		Pag. 3
Item	Quantity	Reference	Part	Description	Part Order Code
50	1	C55	0.1 μ FP	POLIESTER CAPACITOR	CPE104DK101
51	2	C31,C44	1 μ F	ELECTROLYTIC CAPACITOR	CEA105AM630
52	1	C38	1 μ FT	TANTALIUM CAPACITOR	CET105AM350
53	3	C56,C59,C70	2.2 μ F	ELECTROLYTIC CAPACITOR	CEA225AM630
54	8	C19,C23, C47,C50, C57,C66, C68,C69	10 μ F	ELECTROLYTIC CAPACITOR	CEA106AM350
55	4	C62,C65, C67,C71	47 μ F	ELECTROLYTIC CAPACITOR	CEA476BM630
56	3	C53,C58,C74	100 μ F	ELECTROLYTIC CAPACITOR	CEA107BM350
57	8	L2,L3,L5, L8,L9,L10, L11,L12	2 μ 2	RF CHOKE	IMP02U2A
58	3	L7,L13,L14	VK	RF CHOKE	IMPVK00A
59	1	L6	L36RVR	3 SP DIA 6	
60	1	L4	L66RVR	6 SP DIA 6	
61	2	JP2,JP3	2 PIN STRIP	STRIP M P 2.54 2 PIN	CNTSTRIPMCS
62	2	CN3,CN4	10P CONN.	CONN. M 2*5 P 2.54	CNTMCSFC10P
63	1	CN1	BNC C.S.	CONN. BNC A STAMPATO	CNTBNCFCSD
64	2	CN5,CN6	SMB C.S.	CONN. SMB A STAMPATO	CNTSMBMCSD
65	2	D6,D7	OA90	DIODO AL GERMANIO	DIGOA90
66	3	D8,D9,D10	1N4148	SILICON DIODE	DIS1N4148
67	4	D1,D2,D3,D4	MV209	VARICAP DIODE	DIVMV209
68	1	Z1	Z9V1	ZENER DIODE 9.1V 0.4W	DIZ9V10W4
69	1	D5	Z3V9	ZENER DIODE 3.9V 0.4W	DIZ3V90W4
70	1	IC6	78L09	POS. STABILIZER 100mA	CIL78L09
71	1	T9	BC237	NPN TRANSISTOR	TRNBC237
72	2	T5,T6	2N5109	NPN RF TRANSISTOR	TRN2N5109
73	1	T8	BFR96	NPN RF TRANSISTOR	TRNBFR96
74	1	T7	MRF237	RF POWER TRANSISTOR	TRNMRF237
75	1	T4	3N211	MOSFET 2 GATE	TRN3N211

VCO/AF Card

Bill of Materials/Lista Componenti Pag. 4

Item	Quantity	Reference	Part	Description	Part Order Code
76	3	IC8,IC9, IC10	TL082	DOUBLE OP. AMP.	CILTL082
77	2	CN2,R103	N.C.	NOT CONNECTED	
78	1	L1	STRIP LINE	STRIP LINE	

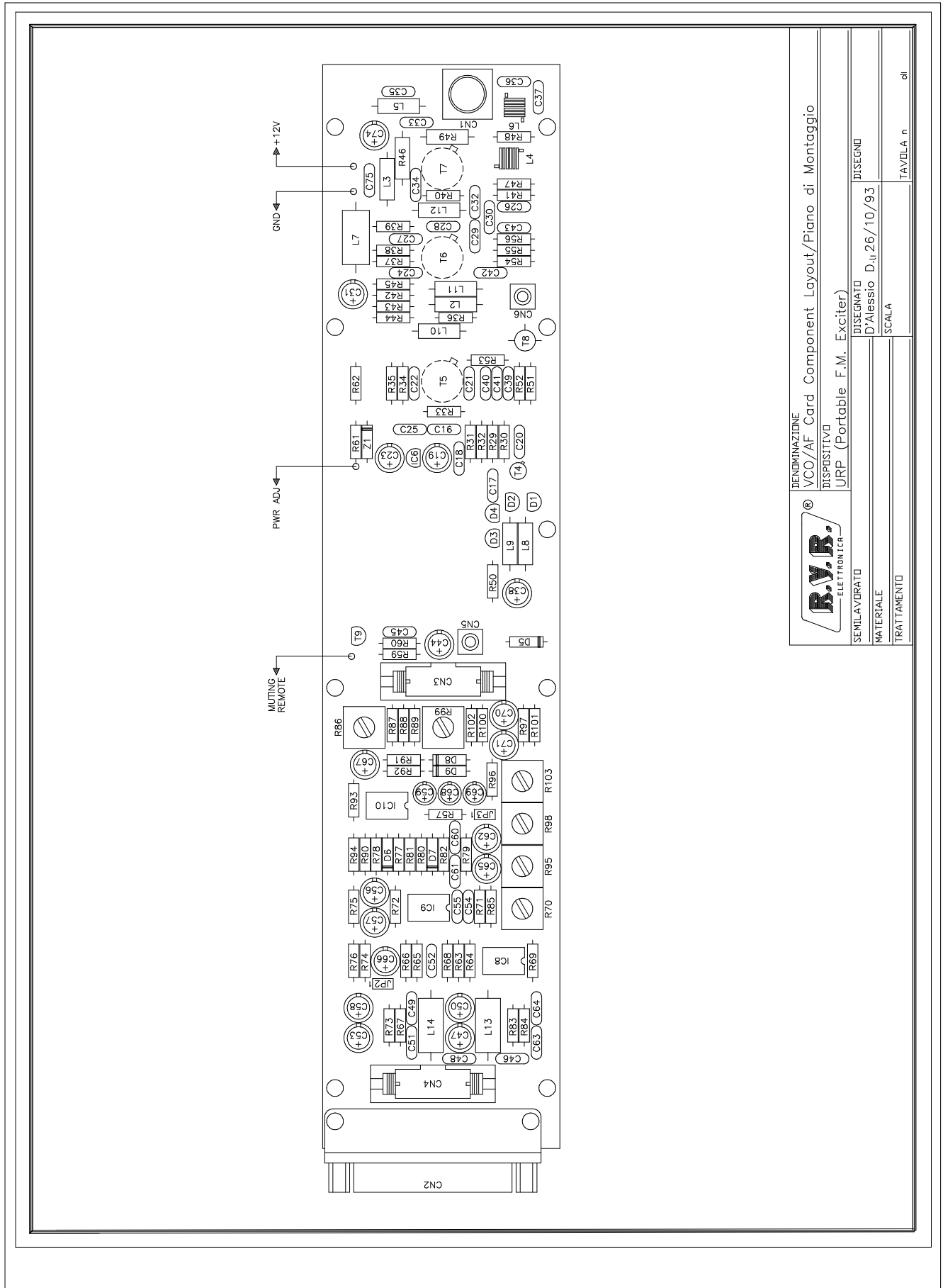

	
DENOMINAZIONE VCO/AF Card Component Layout/Piano di Montaggio	
DISPOSITIVO URP (Portable F.M. Exciter)	
SEMILAVORATO	DISEGNATO D'Alessio D.ii.26/10/93
MATERIALE	SCALA
TRATTAMENTO	TAVOLA n. di

© Copyright 1993
Second Edition - July '96
Created By D'Alessio D. & Morotti M.

R.V.R. Elettronica S.r.l. (Bo)
ViadelFonditore2/2c - 40138 - Bologna (Italy)
National: Tel. (051) 601.05.06 r.a. - Fax (051) 601.11.04
International: Phone +39 51-601.05.06 - Fax +39 51-601.11.04

Printed and bound in Italy. All rights reserved. No part of this manual may be reproduced or utilized in any form or by any means, electronic or mechanical, including photocopying, recording, or by any information storage and retrieval system, without permission in writing from the publisher.

Tutti i diritti sono riservati. Stampato in Italia. Nessuna parte di questo libro può essere riprodotta, memorizzata in sistemi di archivio, o trasmessa in qualsiasi forma o mezzo, elettronico, meccanico, fotocopia, registrazione o altri senza la preventiva autorizzazione scritta dell'editore.