TOUCH30S



User Manual

Volume 1: User Manual

Manufactured by  Italy



File name: capitoli_en.P65

Version: 2.1

Date: 11/06/2003

Revision History

Version	Date	Reason	Editor
2.0	13/12/2002	New version	D. Canazza
2.1	11/06/2003	Add telemetry board	J. Berti

TOUCH30S - User Manual

Versione 2.1

© Copyright 2003

R.V.R. Elettronica SpA

Via del Fonditore 2/2c - 40138 - Bologna (Italia)

Telefono: +39 051 6010506

Fax: +39 051 6011104

Email: info@rvr.it

Web: www.rvr.it

All rights reserved

Printed and bound in Italy. No part of this manual may be reproduced, memorized or transmitted in any form or by any means, electronic or mechanic, including photocopying, recording or by any information storage and retrieval system, without written permission of the copyright owner.

Table of Contents

1. Preliminary Instructions	1
2. Warranty	3
3. First Aid	5
3.1 Treatment of electrical shocks	5
3.2 Treatment of electrical Burns	6
4. General Description	7
4.1 Main Characteristics	7
4.2 Meter Readings	8
4.3 Microprocessor Section	8
5. Quick Reference	9
6. Use	11
6.1 First Use	11
6.2 Visualization mode	14
6.3 Programming mode	16
6.4 General advises	18
7. External description	21
7.1 Connectors description	23
8. Technical Specifications	25
8.1 R.F. Characteristics	25
8.2 Stereo Operation	26
8.3 Mono Operation	26
8.4 S/N Ratio	26
8.5 Audio Inputs	27
8.6 Audio Outputs	27
8.7 Environmental Characteristics	28
8.8 Mechanical Characteristics	28
9. Identification and access to the modules	29
9.1 Circuit description	29

This page was intentionally left blank

1. Preliminary Instructions

This manual is written as a general guide for those having previous knowledge and experience with this kind of equipment, well conscious of the risks connected with the operation of electrical equipment.

It is not intended to contain a complete statement of all safety rules which should be observed by personnel in using this or other electronic equipment.

The installation, use and maintenance of this piece of equipment involve risks both for the personnel performing them and for the device itself, that shall be used only by trained personnel.

R.V.R. Elettronica SpA doesn't assume responsibility for injury or damage resulting from improper procedures or practices by untrained/unqualified personnel in the handling of this unit.

Please observe all local codes and fire protection standards in the operations of this unit.



WARNING: always disconnect power before opening covers or removing any part of this unit.

Use appropriate grounding procedures to short out capacitors and high voltage points before servicing.



WARNING: this device can irradiate radio frequency waves, and if it's not installed following the instructions contained in the manual and local regulations it could generate interferences in radio communications.

This is a "CLASS A" equipment. In a residential place this equipment can cause hash. In this case can be requested to user to take the necessary measures.

R.V.R. Elettronica SpA reserves the right to modify the design and/or the technical specifications of the product and this manual without notice.

This page was intentionally left blank

2. Warranty

Any product of **R.V.R. Elettronica** is covered by a 24 (twentyfour) month warranty.

For components like tubes for power amplifiers, the original manufacturer's warranty applies.

R.V.R. Elettronica SpA extends to the original end-user purchaser all manufacturers warranties which are transferrable and all claims are to be made directly to R.V.R. per indicated procedures.

Warranty shall not include:

- 1 danni verificatisi durante la spedizione della macchina alla R.V.R. per eventuali riparazioni;
- 2 Any unauthorized repair/modification;
- 3 Incidental/consequential damages as a result of any defect
- 4 Nominal non-incidentual defects
- 5 Re-shipment costs or insurance of the unit or replacement units/parts

Any damage to the goods must be reported to the carrier in writing on the shipment receipt.

Any discrepancy or damage discovered subsequent to delivery, shall be reported to **R.V.R. Elettronica** within **5** (five) days from delivery date.

To claim your rights under this warranty, you should follow this procedure:

- 1 Contact the dealer or distributor where you purchased the unit. Describe the problem and, so that a possible easy solution can be detected.

Dealers and Distributors are supplied with all the information about problems that may occur and usually they can repair the unit quicker than what the manufacturer could do. Very often installing errors are discovered by dealers.

- 2 If your dealer cannot help you, contact **R.V.R. Elettronica** and explain the problem. If it is decided to return the unit to the factory, **R.V.R. Elettronica** will mail you a regular authorization with all the necessary instructions to send back the goods.
- 3 When you receive the authorization, you can return the unit. Pack it carefully for the shipment, preferably using the original packing and seal the package perfectly. The customer always assumes the risks of loss (i.e., R.V.R. is never responsible for damage or loss), until the package reaches R.V.R. premises. For this reason, we suggest you to insure the goods for the whole value. Shipment must be effected C.I.F. (PREPAID) to the address specified by R.V.R.'s service manager on the authorization



DO NOT RETURN UNITS WITHOUT OUR AUTHORIZATION AS THEY WILL BE REFUSED

- 4 Be sure to enclose a written technical report where mention all the problems found and a copy of your original invoice establishing the starting date of the warranty.

Replacement and warranty parts may be ordered from the following address. Be sure to include the equipment model and serial number as well as part description and part number.



R.V.R. Elettronica SpA
Via del Fonditore, 2/2c
40138 BOLOGNA
ITALY
Tel. +39 051 6010506

3. First Aid

The personnel employed in the installation, use and maintenance of the device, shall be familiar with theory and practice of first aid..

3.1 Treatment of electrical shocks

3.1.1 If the victim is not responsive

Follow the A-B-C's of basic life support

- Place victim flat on his back on a hard surface.
- Open airway: lift up neck, push forehead back (Fig. 3-1).
- clear out mouth if necessary and observe for breathing
- if not breathing, begin artificial breathing (Figure 3-2): tilt head, pinch nostrils, make airtight seal, four quick full breaths. Remember mouth to mouth resuscitation must be commenced as soon as possible



Figure 3-1



Figure 3-2

- Check carotid pulse (Fig 3-3); if pulse is absent, begin artificial circulation (Fig. 3-4) depressing sternum (Fig. 3-5)



Figure 3-3

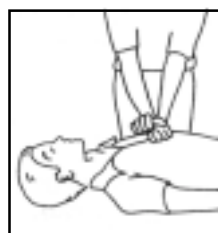

Figure 3-4

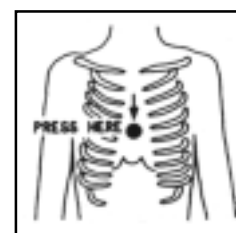

Figure 3-5

- In case of only one rescuer, 15 compressions alternated to two breaths.
- If there are two rescuers, the rhythm shall be of one breath each 5 compressions.
- Do not interrupt the rhythm of compressions when the second person is giving breath.
- Call for medical assistance as soon as possible.

3.1.2 If victim is responsive

- Keep them warm
- Keep them as quiet as possible
- Loosen their clothing (a reclining position is recommended)
- Call for medical help as soon as possible

3.2 Treatment of electrical Burns

3.2.1 Extensive burned and broken skin

- Cover area with clean sheet or cloth
- Do not break blisters, remove tissue, remove adhered particles of clothing, or apply any salve or ointment.
- Treat victim for shock as required.
- Arrange transportation to a hospital as quickly as possible.
- If arms or legs are affected keep them elevated

If medical help will not be available within an hour and the victim is conscious and not vomiting, give him a weak solution of salt and soda: 1 level teaspoonful of salt and 1/2 level teaspoonful of baking soda to each quart of water (neither hot or cold). Allow victim to sip slowly about 4 ounces (half a glass) over a period of 15 minutes. Discontinue fluid if vomiting occurs



DO NOT give alcohol

3.2.2 Less severe burns

- Apply cool (not ice cold) compresses using the cleansed available cloth article.
- Do not break blisters, remove tissue, remove adhered particles of clothing, or apply salve or ointment.
- Apply clean dry dressing if necessary.
- Treat victim for shock as required.
- Arrange transportation to a hospital as quickly as possible
- If arms or legs are affected keep them elevated.

4. General Description

The TOUCH30S is an exciter for FM audio broadcasting able to transmit in the band between 87.5 and 108 MHz with an output RF power adjustable up to a maximum of 30 W

The TOUCH30S can be used like exciter of an amplifier of greater power, or like transmitter directly in antenna.

4.1 Main Characteristics

- State of the art performances at moderate cost .
- Controlled through microprocessor - programmable externally through PC via RS232.
- Extremely low distortion THD, IMD & TIM (Transient Intermod. Distortion) specified.
- Very silent operation (S/N).
- Highest stereo performances: separation 80 Hz*15 kHz typ. 65 dB (30*80Hz typ. 56dB).
- L, R (balanced & unbalanced), RDS / SCA, AUX, MPX.
- 0, 50 o 75us preemphasis .
- Easy to handle: comprehensive monitoring of all relevant parameters and setting values.
- Modular construction, easy to customise and fast to test. Auxiliary functions as special encoders on request. Smartly designed to minimise spare parts
- All solid state using RF Power Mosfet in output module, LDMOS in driver stage.
- Automatic Power Control (APC) maintains required RF power at 45°C & at 1.3:1 VSWR. Higher value of VSWR causes the power reduction.
- Lightweight RF power module, can be removed from mainframe and replaced in less than 5 minutes.
- Nominal RF o/p level = 30W / typical max power in excess of 35 W. Power output continuously adjustable.
- Built-in RF harmonic filter and true wattmeter.
- High spectral purity: > -100 dBc spurious, >-75dBc harmonics (typ.).
- Provides the following outputs: RF, RF monitor, 19 kHz to lock RDS, RS232, RS485 remote alarm, and remote memory setting. Rds available.
- AC mains in switching mode selectable between 95 and 130 V_{ac} beyond 195 and 265 V_{ac}.

- CCIR & FCC compliant.

4.2 Meter Readings

- Forward power.
- Reflected power.
- DC Supply voltages.
- Frequency
- Mono and stereo sensitivity (0.25 dB step).
- Output power programmed.
- MPX peak modulation.
- L & R peak level.
- Rds, Sca, Aux, MPX ext modulation.
- Audio programmed parameters (+L or -L, +R or -R, L on/off, R on/off, Preemphasis lin, 50, 75 mS, Limiter on/off, Input Impedance Z=10KOhm/ 600 Ohm,
- Alarm status
- Memory status
- Internal voltages
- Serial Number

4.3 Microprocessor Section

- All functions are controlled by 9 keys and a 2-rows/16 characters LCD display.
- RS232 (on front panel), DB9 socket I/O
- RS485 (on rear panel) RJ45 socket
- Interlock input on connector DB9: 4 pin for interlock (2 jumper normally closes). A predisposed connector is supplied with the machine.
- Firmware upgradable, via RS232 connection and an external PC
- Friendly parameters configuration
- Customizable slides on the LCD display with address, web, phone, network identification or local sales organization, can be inserted on demand.

5. Quick Reference

The following instruction permits you to manage this transmitter quickly.

- 1) Two modes of operation are possible:
 - Single visualization mode
 - Programming mode
- 2) You can move between various slides by using the four "function keys" (audio, frequency, power, check) and the up & down keys of the "navigation ring".
- 3) Pushing the central button of the "navigation ring" for more than 4 sec., you can enter to the programmable functions menus.
- 4) You can program all audio functions and audio parameters, frequency, power etc. When a value as been modified press the central button to confirm.
- 5) Una volta programmati, i dati verranno memorizzati premendo a lungo il tasto centrale. Se nel frattempo non viene effettuata nessuna regolazione per i successivi due minuti (tempo di abbandono) il trasmettitore chiude automaticamente la modalità di programmazione e tutti i nuovi dati, compresi quelli modificati, non verranno memorizzati.

Once programmed, the data will come memorized pushing the central key for long time. If in the meantime does not come made any regulation for two minutes (abandonment time) the transmitter closes automatically the programming mode and all the new data, comprised those modified, will not come memorized.

This page was intentionally left blank

6. Use

This FM transmitter has been projected to be operated in a manner as simple and consistent as possible.

Many options/selections are accessed by an easy direct action dedicated keys and thematic subsequent menus.

A full description of the menus and how to move around them is described in the later sections.

6.1 First Use

6.1.1 Demounting instructions



WARNING : before the instalation follow this instructions:

- REMOVE THE TWO SCREWS BLOCKING THE COVER
- SLIDE OUT THE COVER
- REMOVE THE FOAM CUBE HOLDING THE VCO
- CLOSE THE COVER WITH THE TWO SCREWS
- USE THE TRANSMITTER IN HORIZONTAL POSITION

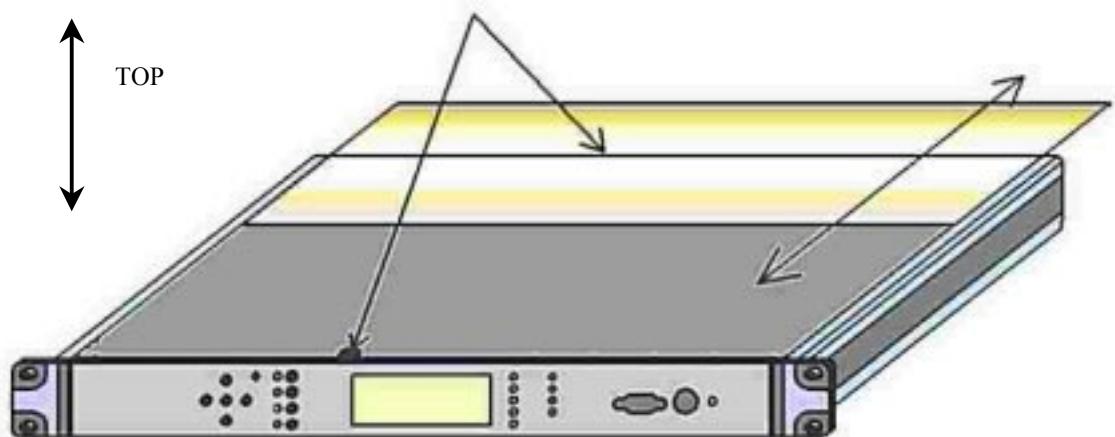

REMEMBER: Insert supplied PLUG into DB 9 CONNECTOR located on rear panel to allow the power distribution(interlock)

6.1.2 Power supply requirements and setting

Inserire la spina di alimentazione nella presa VDE presente nel pannello posteriore.

Insert the mains plug in the VDE place in the rear panel.

The power supply can work at any voltage between 95 and 130 Vac or between 195 and 265 Vac. A label on the rear, glued close to the ON/OFF switch, indicates the preset voltage range. If you want to change this voltage, or for fuse replacement, follow next instructions:

- SWITCH-OFF AND DISCONNECT from mains the equipment
- Open the transmitter (see standard "demounting" instructions)
- Unscrew the cover of the power supply (please control if the plug of input power cord is out of its receptacle!), see photo:

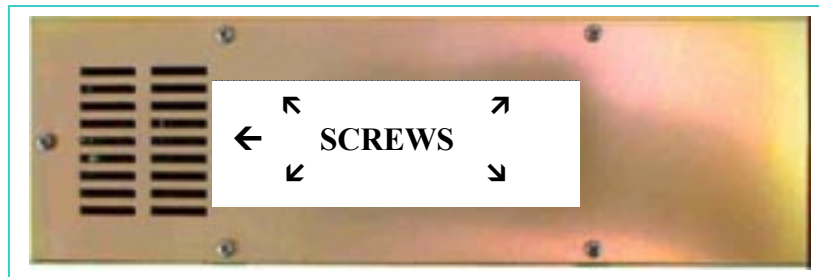

- Slide out the internal black plastic cover of the mains socket and change the two fuses.
- Replace the fuses by using two 1.25 A fuses for 220/230 V range and 2.5 A for 110/117 V. Insert the plastic cover.
- Move the jumper in the position "A" for 110V and "B" for 220V:

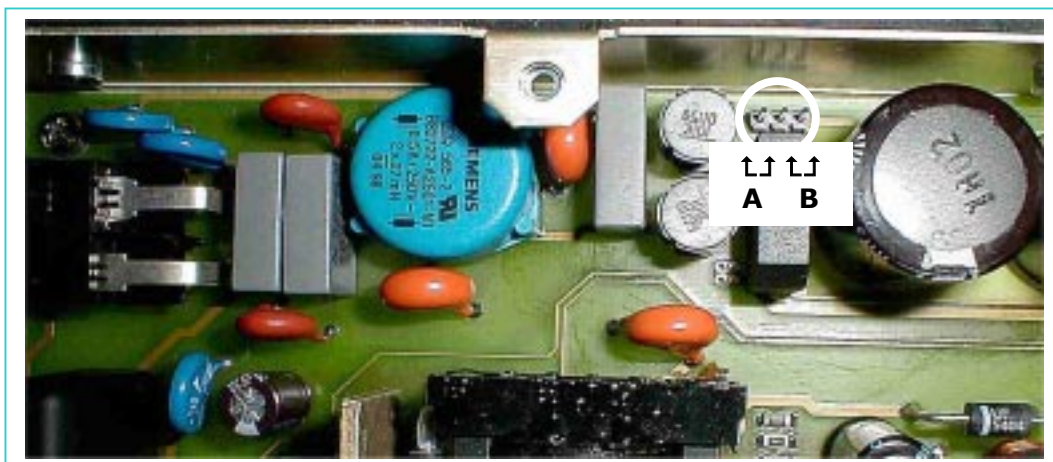

- Place the supply cover in the original position and fix the screws.
- Close the transmitter with the top cover.

- **PAY ATTENTION:** the transmitter cannot work without the cover. The air-cooling system is designed to work in a closed box.



Serious problems can result if the transmitter is operated without cover.

- Reconnect the mains.

6.1.3 Switch On

Connect the transmitter to a 30 W dummy load and start it by the switch (03 pag.22) placed on the rear panel.

The first image that you see in the front display is similar to:



```
Freq: 97.70 MHz
Step: 10 KHz
```

The PLL (phase locked loop) enters in function and are necessary approximately 10-40 sec. (depends on the frequencies) because the oscillator locks on the established frequency. The slowness of the operation is due to a slow answer of the PLL filter that is designated in order to increase the stereo separation to the lower audio frequencies.

6.1.4 Keyboards and indicators description and use

Are presents nine key on the front panel that control the transmitter.

The five buttons placed in the left side of the front panel (identified in page 21 from numbers 06 to 10) are necessary to "navigate", in usual mode, through various slides and functions.

The central button (10 pag.21) is a standard "ENTER" key. By pushing this key for a long time you have access to program functions and you can change various parameters. An equivalent long action closes the access to program and the transmitter returns to visual mode operations.

The other four buttons are (listed in sequence):

- "AUDIO" (audio function) (11pag.21)
- "FREQ" (frequencies programming) (12 pag.21)
- "RF PWR" (power programming) (13 pag.21)
- "CHK" (information and control slides) (14 pag.21)

When the red LED (05 pag.21) is lighting, the program mode is active and the operator must be very alert.

The four green LEDs (01 pag.21), (02 pag.21), (03 pag.21), (04 pag.21) indicate selection of the correspondent key.

The lighting of the five red LEDs (16 pag.21), (17 pag.21), (18 pag.21), (19 pag.21), (20 pag.21) indicates:

- Transmitter unlocked (PLL)
- Internal limiter disabled
- Preemphasis disabled
- RF OUT disabled
- An external alarm is active

The four yellow LEDs (21 pag.21), (22 pag.21), (23 pag.21), (24 pag.21) indicate the active memory M1 to M4 (not implemented).

The green LED (27 pag.21) is the standard "power" indicator.

The DB9 connector (25 pag.21) permits the RS232 connection to the PC.

The last connector (26 pag.21) is a BNC female type for monitoring and measurement purposes.

6.2 Visualization mode

It's possible to check all parameters and stored data, without modifications, during the normal functioning of the equipment. The available menus regard audio setting, frequency setting, internal supply voltages control, general information about firmware version, Internet manufacturer's web, serial number etc.

6.2.1 Audio menu

The audio menu, through the selection of the UP (08 pag.21) and DOWN (09 pag.21) buttons, shown the follow parameters:

1) L & R bars show the peak modulation. The filled square blocks indicate 10%/ each of modulation, unfilled block show 100% modulation.

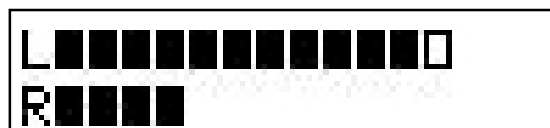

2) Peak deviation indicator. Unfilled block= 75 kHz



3) SCA/RDS peak deviation indicator. Unfilled block= 7.5 kHz

```

Sca/Rds      : 7.5K
>■■
    
```

4) 19kHz % control bar. (internally adjustable)

```

19K%  8:9:10:11:
    
```

5) AUX peak deviation indicator. Unfilled block= 7.5 kHz

```

Aux         : 7.5K
>■■■■
    
```

6) All set audio parameters synthesis slide :

```

HiZ 50uS Lim:Off
-0.50dBm Mo:+L+R
    
```

- HI-Z: Impedenza degli ingressi bilanciati. Scelta tra 10 Kohm (HI-Z) o 600 Ohm (LO-Z).
- 50uS : Preemphasis value. You can choose between "FLAT" (no preemphasis) and 50/75 uS. The value, that is depending on specific local rules, can be modified by moving a jumper located on the mother board.
- Limiter OFF: status of internal limiter. This limiter, when active, performs a strong cutting of all peaks that exceed the authorized 75kHz deviation
- -0.50dBm. Audio sensitivity. You can set this value from -3.75 and 12 dBm in 0.25 dB/step. Remember that 0 dBm = 1mW on 600 Ohm or 774 mVeff. or 2.19 Vpp.
- MO = Mono. The internal coder stereo is disable. To able select ST = Stereo.
- +L, +R is the channels status and fase. The other options are -L, +R; -L, -R; +L (R=off); -L (R=off); +R (L=off); -R (L=off).

6.2.2 Frequency menu

When you push the audio button a slide similar to the following will appear:

```

Freq: 97.70 MHz
Step: 10 KHz
    
```

6.2.3 R.F. power menu

The following image is an example of the slide obtained pressing the RF PWR button (13 pag.21) :



```
Fwd: 1.97W
Ref: 1.22W RF=ON
```

- Fwd: forward power measure
- Ref: reflected power measure
- RF: distributed power status (ON or OFF)

6.2.4 Information and control menu

This slide shows for control purposes:

- V + : Positive internal power supply +7.5V ($\pm 0.15V$)
- V - : Negative internal power supply -7.5V ($\pm 0.15V$)
- VRF: power supply voltage of the final stage of power . This voltage can varies between 5V and 28V depending by the RF output power.
- Vtu: VCO voltage expressed in percentage.

These informations are interesting for the technicians in case of a failure taken place.



```
V+ :7.45 VRF: 6.6
V- :7.40 Vtu: 37%
```



One more screen is present in this menù, that shows the software version and the serial number of the machine.

6.3 Programming mode

In order to vary the different parameters of the transmitter is necessary to enter the programming mode.

In order to begin, select the parameter to change and to press the corresponding key, press for some seconds key "ENTER" (10 pag.21) (the central key of the navigation keys). The red LED (05 pag.21) will illuminate itself. This indicates that the access to the modification of the parameters of the apparatus has been made

6.3.1 Audio setting menu

Let's start from the audio key: There are five pages available containing data to insert:

- Sensitivity: is the input level sensitivity (it refers to the L and R balanced input placed on the rear panel). The value can be set from -3.75 and 12 dBm with 0.25dB step, as described in the following picture:

```
Sensitivity:
P1/5  -0.50dBm
```

It is needed to move the cursor under the character that you want to modify, increasing or decreasing the value with the UP and DOWN keys

- The second page allows you to program the input impedance value. The two permitted values are 600 Ohm or 10 kOhm:

```
Impedance:
P2/5  Z=10K Ohm
```

- The third page allows you to set the limiter status and the preemphasis value:

The value of 50uS o 75uS depends on the different rules and can be set inside equipment by shifting a jumper bridge.

The processor recognises the internal set value showing it on the display.

```
PRE LIMITER
P3/5  50uS  Off
```

- The fourth slide sets the input status as Left: +, -, On, Off; and Right : +, -, On, Off:

```
Status:
P4/5 +L=On +R=On
```

- The fifth and last page sets the transmission mode between mono and stereo:

```
Mode:
P5/5  Mono
```

```
Mode :  
P5/5 Stereo
```

Therefore the programming of the AUDIO parameters finishes. As last step will be necessary confirm with "ENTER" key and will appear to confirm the modifications the slide of LOADING.

6.3.2 Frequency setting menu

It is possible to program the frequency very easily by observing the following picture:

```
Frequency  
MHz 105.000
```

The cursor must be moved under the character with LEFT and RIGHT keys and then the value can be modified through the UP and DOWN keys.

The range limits are: 87.50 MHz e 108,00 MHz. The default step is 10kHz but it is possible, on request, to choose different step values (i.e. 25 or 50 kHz).

At the end press ENTER to confirm. The modification can, in any case, be abandoned selecting NO at the moment of the demand for confirmation.

```
ARE YOU SURE  
YES/NO
```

6.3.3 RF power setting menu

```
Fwd: 1.97W  
Ref: 1.22W RF=ON
```

Through the UP and DOWN keys is possible choose the wished power value observing at the same time the effect.

6.4 General advises

6.4.1 Ordinary precautions

To maintain the transmitter in a good state in long operating times, we suggest to read the following instructions:

- Make sure that the rear part is ventilated adequately. If the internal temperature of the RACK, where the transmitter is contained, is too much high (we recommend that the temperature does not exceed the 40°C) make sure that comes guaranteed the adequate ventilation.
- Not operate without the cover of the container. Moreover make sure that the cover is placed and pushed until the end of the rabbet.
- Avoid that the voltage variations exceed the limits. The worse conditions take place with lower power RF (p.e. 5W) and with higher mains voltage (p.e. 250V) or viceversa.
- Not exceed the maximum power of 30W. The transmitter can increase of 10% this power. Not allow that these limits are exceeds.
- Improved versions of the software will be prepared. Ask to your retailer approximately the upgraded versions of our software or visit our web address.

This page was intentionally left blank

7. External description

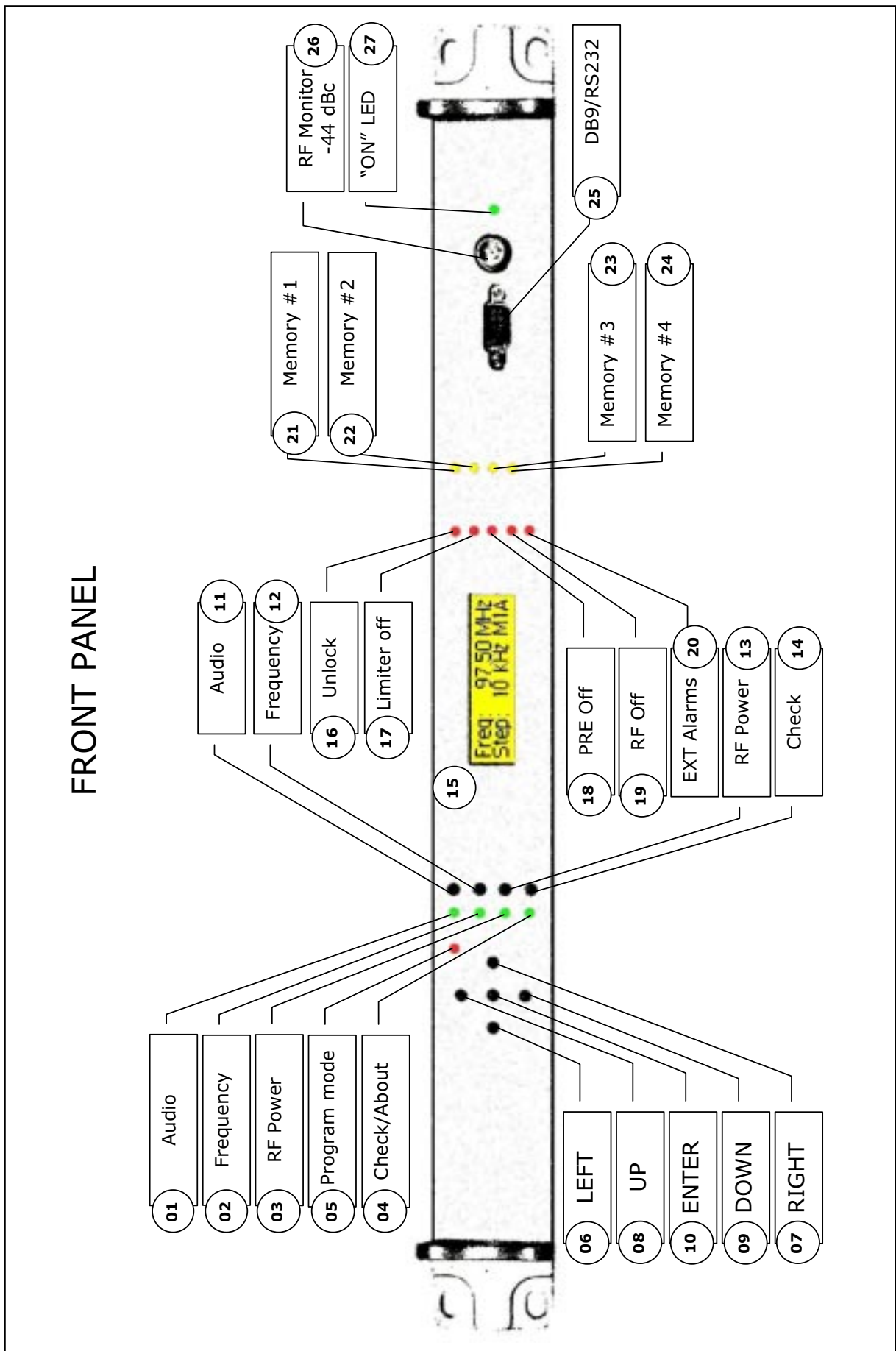

REAR PANEL

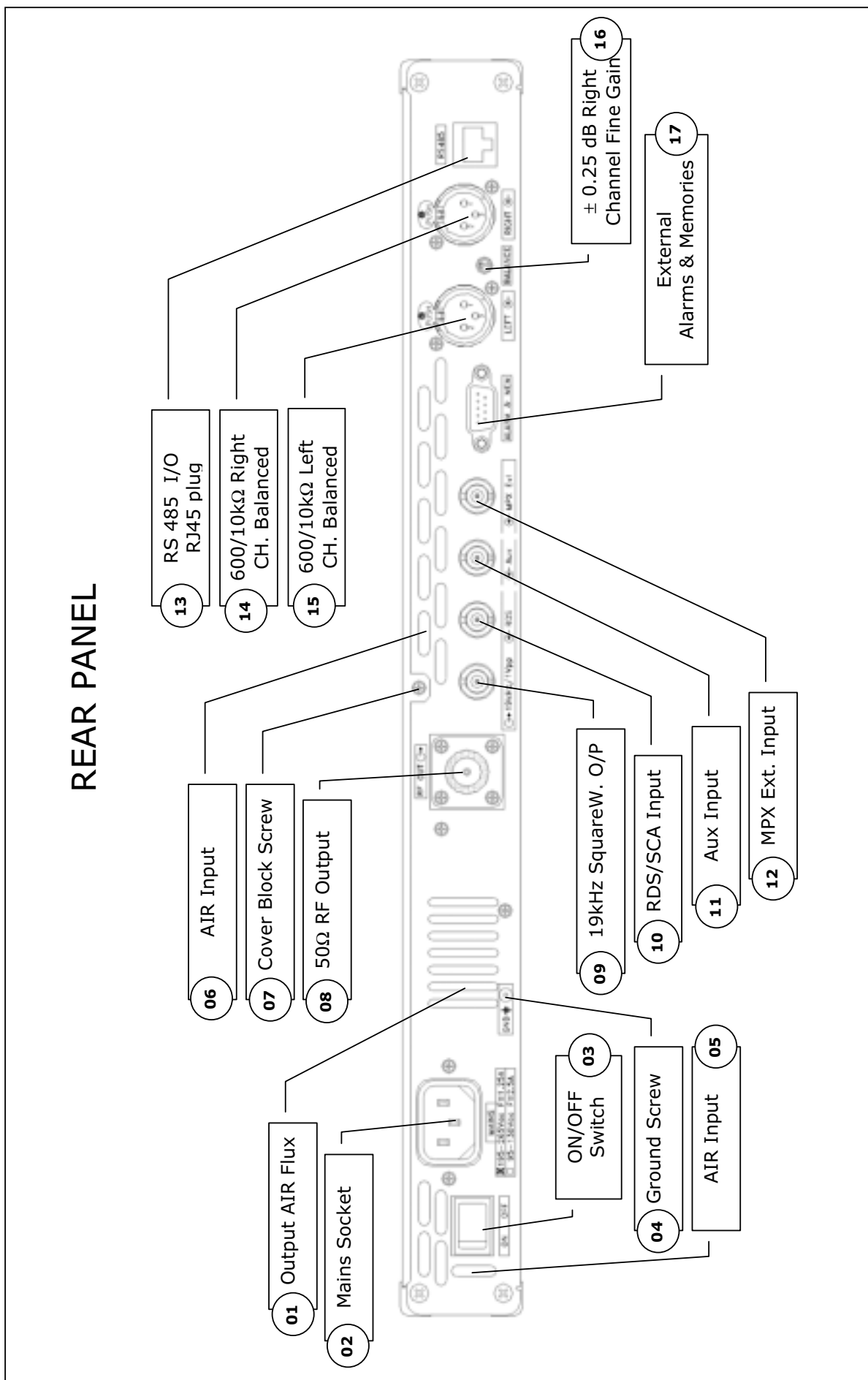

7.1 Connectors description

7.1.1 RS232

Type: DB9 female

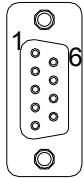

1	Set B
2	Set A
3	GND
4	Ext 2
5	Ext 1
6	GND
7	GND
8	GND
9	GND

7.1.2 Left / Right unbalanced inputs

Type: XLR female



1	GND
2	Positive
3	Negative

This page was intentionally left blank

8. Technical Specifications

8.1 R.F. Characteristics

RF CHARACTERISTICS	
1. Power	30 W adjustable from +0.2 dB to -10 dB (-20dB with option "OPT01")
2. RF output impedance	50Ω unbalanced, VSWR less than 1.5:1
3. RF connector	N (7/16 optional).
4. Frequency range	87.5 to 108 MHz, 4 channels (10kHz / step μ p selected) can be stored and recalled from panel, by remote switch command, or via RS232 connection. (25-50-100kHz step with option "OPT02")
5. Frequency control	Synthesizer μ processor controlled
6. Off lock attenuation	> 60 dBc
7. Type of modulation	F3E / F8E direct FM at the carrier frequency
8. Frequency deviation	± 75 kHz =100 %, ± 150 kHz capability
9. Reference	TCXO = 12.8 MHz.
10. Stability of fq. dev.	$\pm 2,5$ % over six months.
11. Variation of fq.	≤ 1 kHz/year (internal TCXO)
12. Short term stability	± 2.5 ppm from -20 to +45 °C (± 1 ppm "OPT 03")
13. Instantaneous BW	20 MHz
14. RF harmonics	Exceeds EBU/CCIR/FCC requirements > -75dBc
15. RF spurious	Exceeds EBU/CCIR/FCC requirements < -100 dBc @ ± 1 MHz min. out of carrier
16. Preemphasis	Flat/50/75 μ s internal jumper setting
17. Stereo operation	CCIR 450/S2 "pilot tone system"
18. Distortion (THD)	Less than 0.07 % (typ. 0.03 %)
19. Intermodulation (IMD)	Less than 0.07 % (typ. 0.03 %)
20. Transient IMD	< 0.15% (square / sine Wave)
21. MPX amplitude response	± 0.15 dB, 30 Hz to 100 kHz
22. Monitor RF output	-44dBc ± 2 dB from 87.5 to 108 MHz

8.2 Stereo Operation

STEREO OPERATION	
1. Audio filter attenuation	> 68 dB @ 19 kHz, >50dB 19 to 100kHz
2. Common mode rejection	> 40 dB typ. (50dB on request "OPT04")
3. Stereo Separation	30÷80Hz >53dB (typ. 56), 80Hz÷15kHz >60 dB (typ.65)
4. Crosstalk attenuation (M / S)	> 45 dB 30 Hz to 15 kHz (typ. 55dB / 100Hz to 8kHz)
5. Spurious products	> 53 kHz > 50 dB
6. 38 kHz suppression	> 60 dB
7. Subcarrier frequency	38 kHz ± 2 Hz
8. Subcarrier generation	Internal crystal
9. Pilot frequency	19 kHz ± 1 Hz
10. Phase difference	19/38 kHz 0°±2° adjustable
11. THD on encoded channels	< 0.1 % 30 Hz TO 15 kHz
12. IMD	60 Hz / 7 kHz 4 :1 RATIO < 0.1 %
13. TIM	< 0.1 % (square/sinus)
14. Audio response	±0.1 dB 20 Hz to 15 kHz
15. Nominal pilot deviation	±7 kHz

8.3 Mono Operation

MONO OPERATION	
1. Audio response	30 Hz to 15 kHz ±0.1 dB
2. THD	30 Hz to 15 kHz < 0.07 % (typ. 0.03 %)

8.4 S/N Ratio

S/N RATIO			
Type	Condition	Value (Peak CCIR)	Value (RMS detector)
Mono Ref. ± 75kHz	Weighted (CCIR 468/2)	83 dB/50 μs 77.5 dB/flat	86 dB/50 μs 80.5 dB/flat
	Unweighted 30 Hz - 20kHz		90.5 dB/50 μs 86 dB/flat
Built-in stereo encoder L & R Or external stereo	Weighted (CCIR 468/2)	73 dB/50 μs 68.5 dB/flat	75.5 dB/50 μs 71.5 dB/flat
	Unweighted 30 Hz ÷20kHz		82 dB/50 μs 77 dB/flat
Am synchronous AM=500 Hz Fm=500 Hz ± 75 kHz Ref. = 100 % AM	$\frac{P^+ + P^-}{2}$	61 dB (detector)	
Am asynchronous Fm = no modulation Ref. = 100 % AM	$\frac{P^+ + P^-}{2}$ Weighted & unweighted	69 dB (detector)	

8.5 Audio Inputs

AUDIO INPUTS						
Function	100 % lev.	BW	Impedance	Type	Conn.	N°
Composite	+6 dBm	0.15 dB 30 Hz÷100kHz	~5 kΩ	Unbal.	BNC	1
Sca/RDS	-20 dBm	0.15 dB 40kHz÷100kHz	~10 kΩ	Unbal.	BNC	2
Aux	-6 dBm (opt. up to +6 dBm)	0.15 dB 40kHz÷100kHz	~10 kΩ	Unbal.	BNC	3
L	-3.75 dBm +12 dBm	0.1 dB 30Hz÷15kHz	10 kΩ 600 Ω	Unbal. Bal.	XLR	4
R	-3.75 dBm +12 dBm	0.1 dB 30Hz÷15kHz	10 kΩ 600 Ω	Unbal. Bal.	XLR	5
<p>L & R inputs can be adjusted in 0.25dB step. The inputs can be programmed and stored by keyboard as: L, -L, R, -R or "off" in any combination</p>						

8.6 Audio Outputs

OUTPUTS						
Function	Level	Bw	Impedance	Type	Conn.	N°
Pilot	1 Vpp	19 kHz Squarewave	>5kΩ	Unbal.	Bnc	6

8.7 Environmental Characteristics

ENVIRONMENTAL	
Storage temperature	-20°C TO + 60 °C
Operating temperature	-5 °C TO + 45 °C
Guaranteed performances temp.	0 °C TO + 40 °C
Relative humidity (non condensing)	90 % MA
Max operating altitude	2000 mt
Max extraneous field strength	≤10 V/m; ≤ 4 A/m
Cooling	Forced convection internal low noise blower

8.8 Mechanical Characteristics

PHISICAL & ELECTRICAL	
Dimensions	Standard 19" chassis /1 U rack
Cabinet	365 mm deep by 485 mm wide, 44 mm height
Weight	Approx. 5 kg.
Finish	Plastic film on aluminum (front panels). Stainless steel (cabinet).
Power supply	110/223V single phase AC (+10 / -15 %) 50-60Hz/ ± 5%

9. Identification and access to the modules

9.1 Circuit description

The transmitter is realized using the following parts:

- 1) Mother Board (**MBG08**)
- 2) Audio Input and attenuators module (**MAB 25**)
- 3) Preemphasis and limiter module (**MPL75**)
- 4) Stereo Audio Filter Module (**AFS15**)
- 5) StereoCoder Module (**SCD02**)
- 6) PLL Module (**MSY01**)
- 7) Measurements module (**MMS04**)
- 8) VCO and 1 W amplifier (**MVA11**)
- 9) RF Power amplifier 30W, Low-Pass Filter (**MPA45**)
- 10) Directional Coupler (**DCA45**)
- 11) SMPS power supply (**SPC28**)
- 12) Logic Board and Display (**MPR51**)
- 13) RS232 Interface (**MIB232**)

The modules (2), (3), (4), (5), (6), (7), are inserted on the mother board (1). The DCA45 (10) block is located inside the same box of the 30 W power amplifier (9).

See following photos:

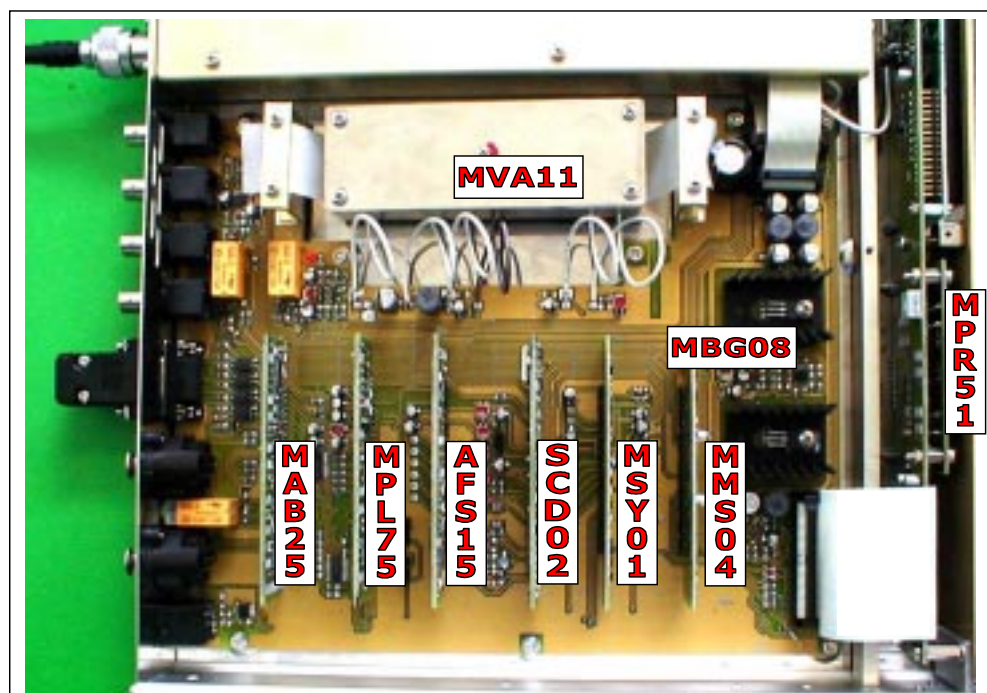

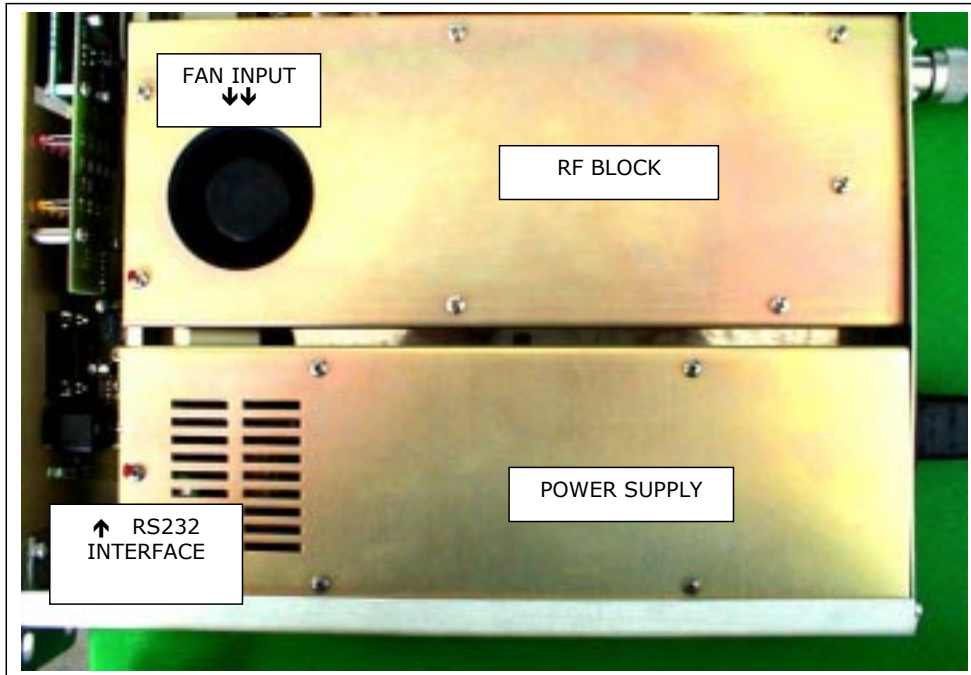

Top view of RF and SMPS block

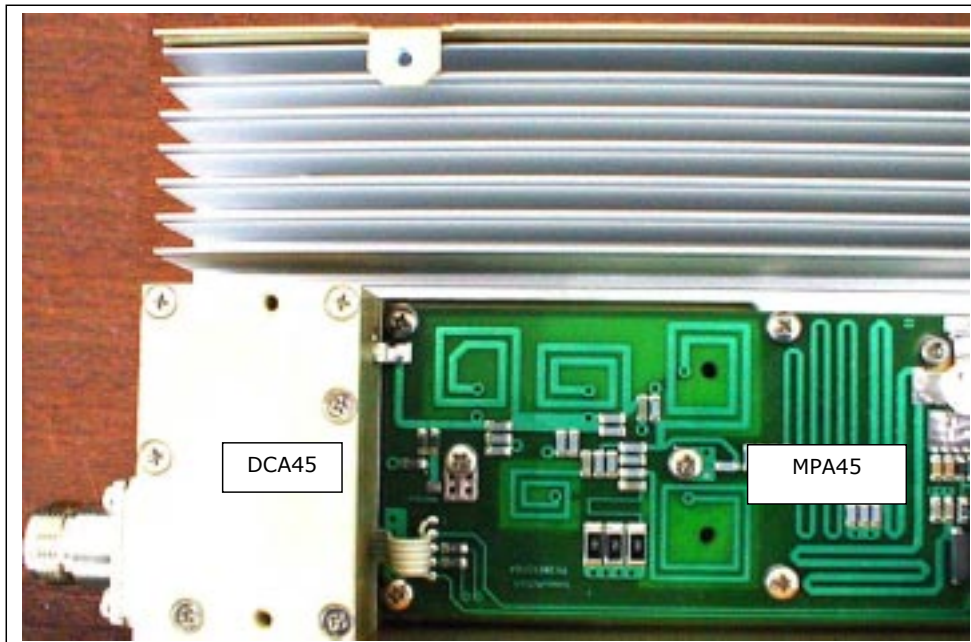

Directional Coupler, printed LO-PASS filter, 30W RF amplifier board

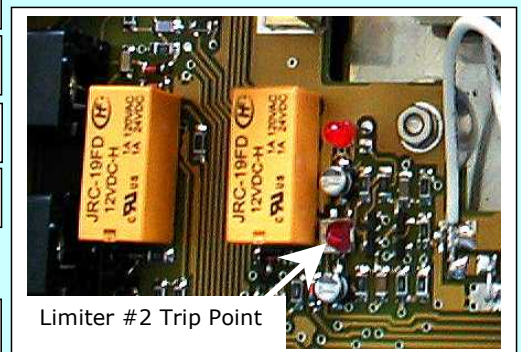
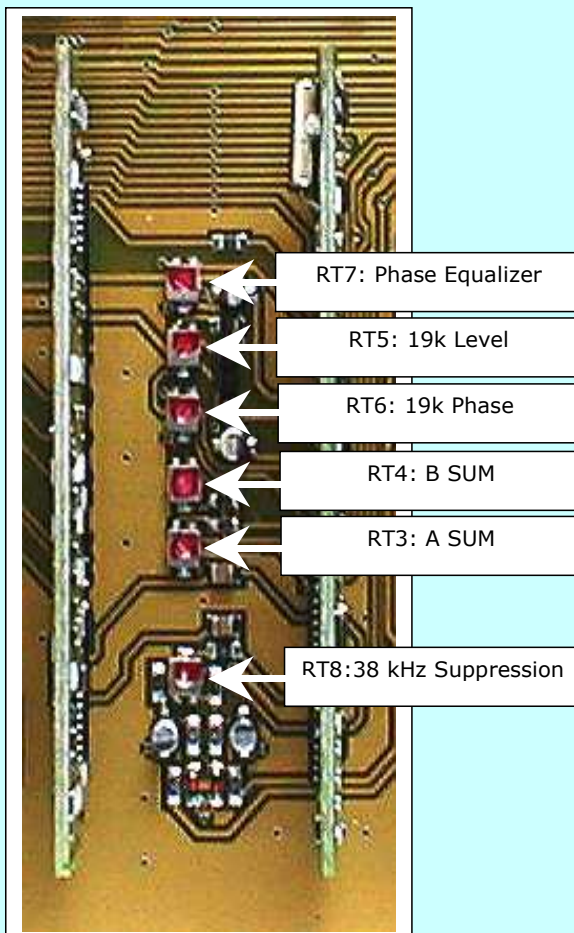
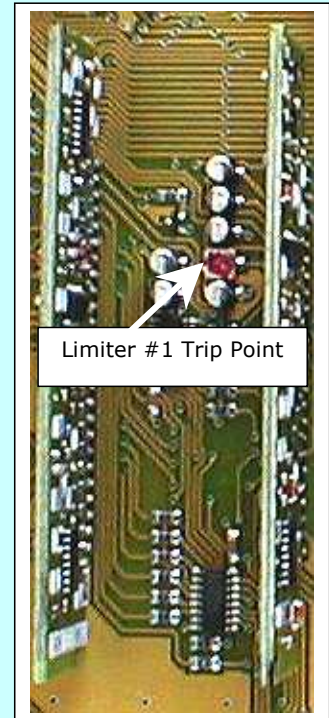
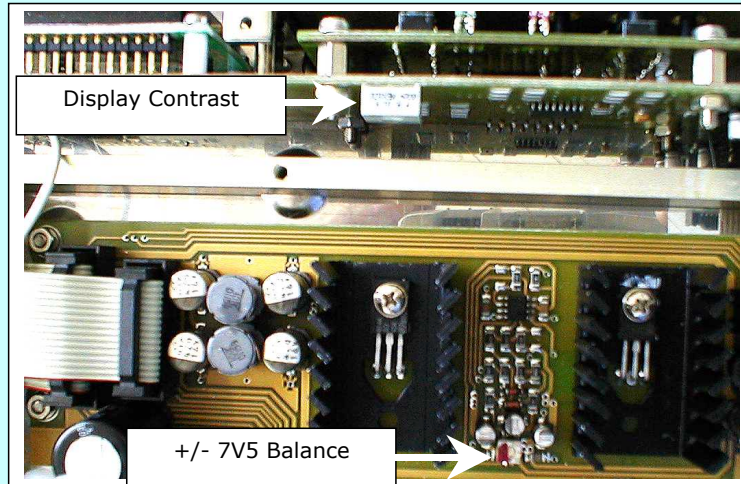

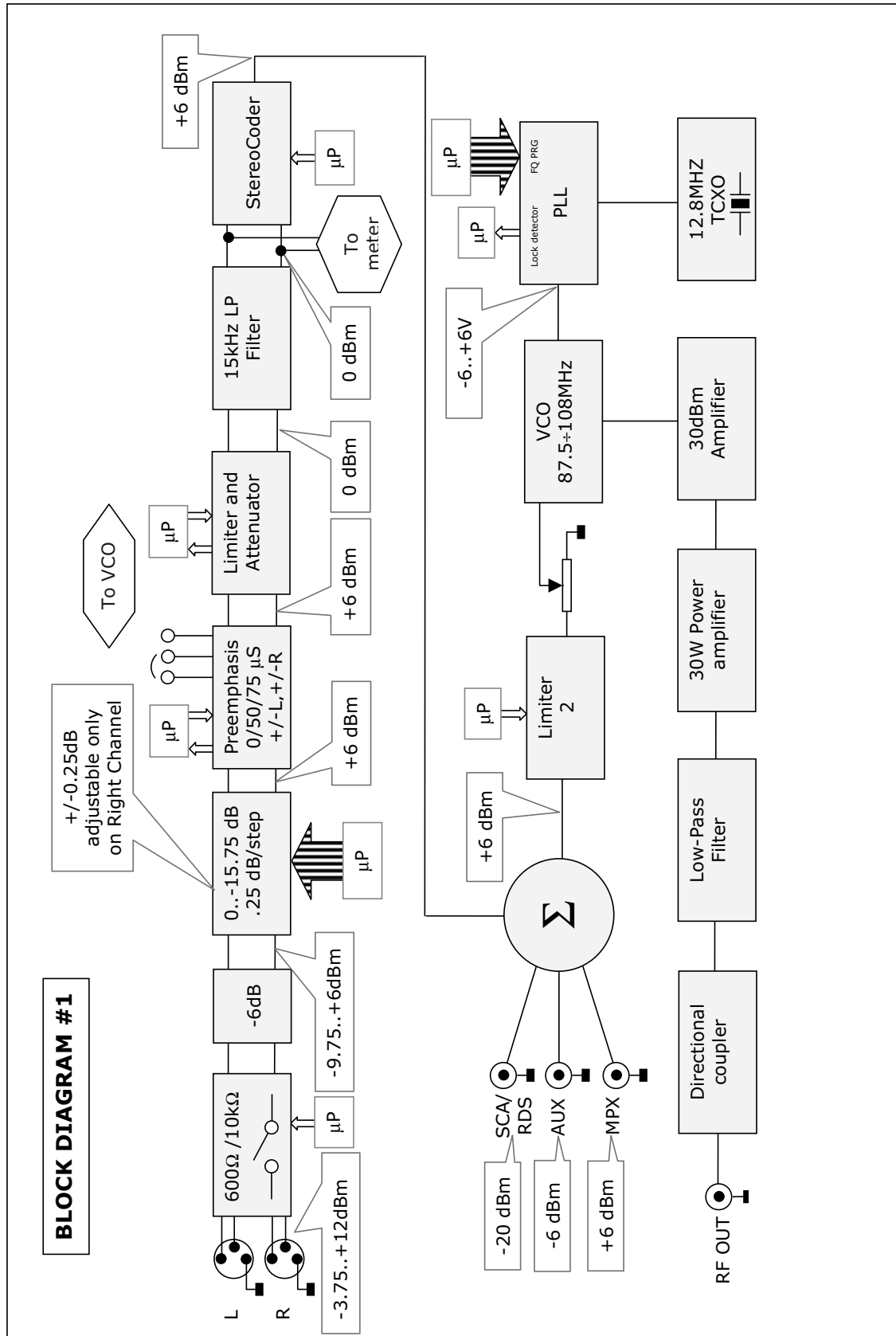

BLOCK DIAGRAM # 2

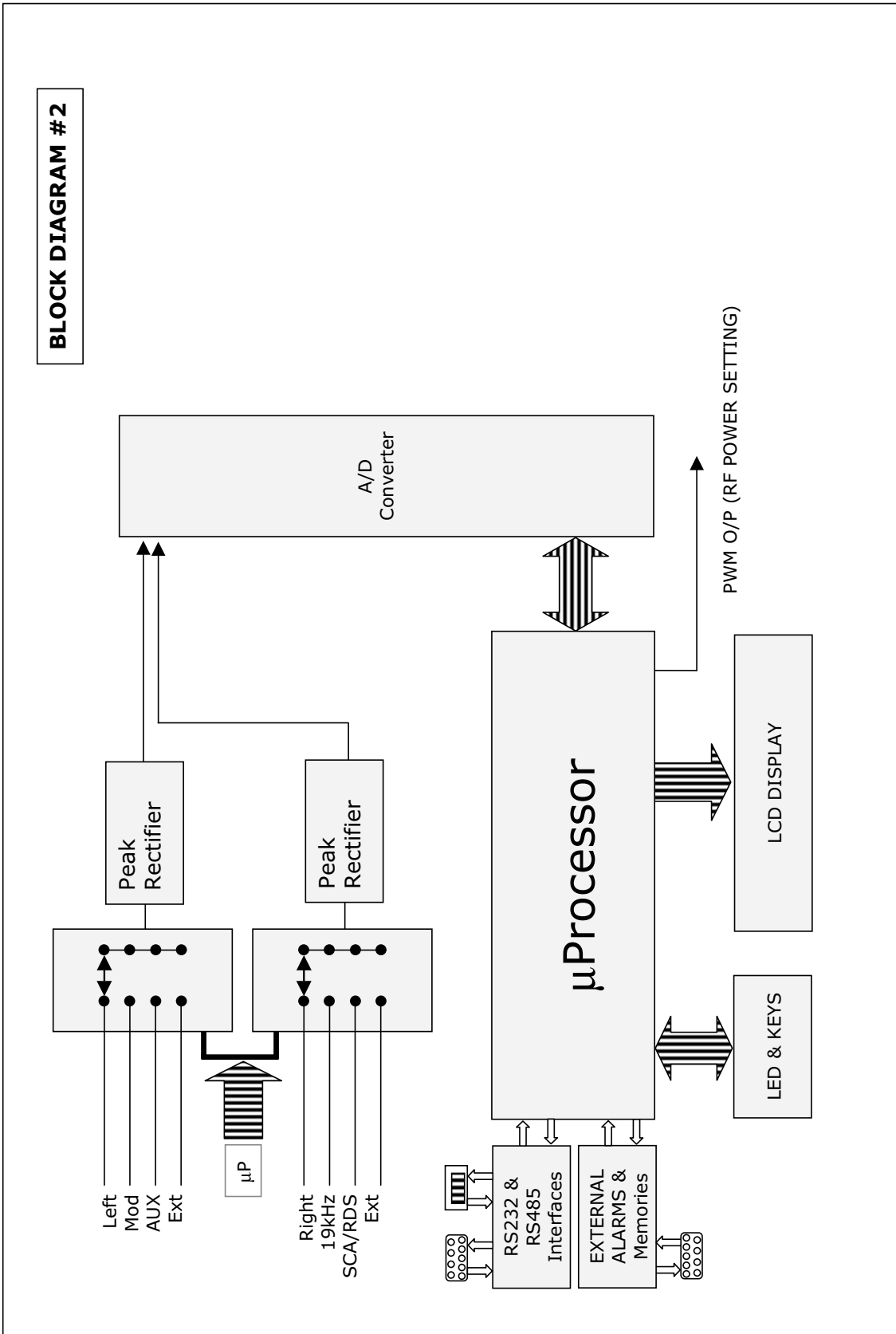

This page was intentionally left blank