

---

---

# SCML1+1SL



## User Manual Volume 1

---

---

Manufactured by



Italy



**File Name:** 03\_SCML1+1SL\_ING\_1.5.indd

**Version:** 1.5

**Date:** 08/06/2016

## Revision History

## Document History

Date	Version	Reason	Editor
05/02/2007	1.1	Minor Corrections	J. H. Berti
02/03/2007	1.2	External Description Integration	J. H. Berti
04/06/2007	1.3	Configurations Figures Update	J. H. Berti
20/05/2014	1.4	Configuration Table Update	J. H. Berti
08/06/2016	1.5	TC/TS Interface Integration	J. H. Berti

SCML1+1SL - User Manual  
Version 1.5

© Copyright 2007-2016  
R.V.R. Elettronica SpA  
Via del Fonditore 2/2c - 40138 - Bologna (Italia)  
Telephone: +39 051 6010506  
Fax: +39 051 6011104  
Email: info@rvr.it  
Web: www.rvr.it

All rights reserved

Printed and bound in Italy. No part of this manual may be reproduced, memorized or transmitted in any form or by any means, electronic or mechanic, including photocopying, recording or by any information storage and retrieval system, without written permission of the copyright owner.

### **Notification of intended purpose and limitations of product use**

This product is a FM transmitter intended for FM audio broadcasting. It utilises operating frequencies not harmonised in the intended countries of use. The user must obtain a license before using the product in intended country of use. Ensure respective country licensing requirements are complied with. Limitations of use can apply in respect of operating frequency, transmitter power and/or channel spacing.

### **Declaration of Conformity**

Hereby, R.V.R. Elettronica SpA, declares that this FM transmitter is in compliance with the essential requirements and other relevant provisions of Directive 1999/5/EC.



# Table of Contents

<b>1.</b>	<b>Preliminary Instructions</b>	<b>1</b>
<b>2.</b>	<b>Warranty</b>	<b>1</b>
<b>3.</b>	<b>First Aid</b>	<b>1</b>
3.1	Treatment of electrical shocks	1
3.2	Treatment of electrical Burns	2
<b>4.</b>	<b>Unpacking</b>	<b>3</b>
4.1	General Description	3
<b>5.</b>	<b>Configurations</b>	<b>4</b>
5.1	Typical Configuration with Exciters of Tex and Blues family	4
5.2	Typical Configuration with Exciters of PTX family	6
5.3	Typical Configuration with Mixed Exciters	7
5.4	Typical Configuration with Transmitting systems	8
5.5	User Interface	9
5.6	Management Firmware	10
<b>6.</b>	<b>External Description</b>	<b>14</b>
6.1	Front Panel	14
6.2	Rear Panel SCML1+1SL/V1	15
6.3	Rear Panel SCML1+1SL/V2	16
6.4	Rear Panel SCML1+1SL/V3	17
6.5	Rear Panel SCML1+1SL/V4	18
6.6	Connectors Description	19
<b>7.</b>	<b>Technical Specifications</b>	<b>22</b>
7.1	Electrical characteristics	22
<b>8.</b>	<b>Internal Description</b>	<b>24</b>
8.1	SCML1+1SL/V1	24
8.2	SCML1+1SL/V2	25
8.3	SCML1+1SL/V3	26
8.4	SCML1+1SL/V4	27
<b>9.</b>	<b>TC/TS Electromechanical Interface</b>	<b>22</b>

*This page was intentionally left blank*

**IMPORTANT**

The lightning flash with arrowhead, within a triangle, is intended to alert the user of the presence of dangerous voltage that may constitute a risk of electric shock.



The exclamation point within an equilateral triangle is intended to alert the user to the presence of important operating and maintenance (servicing) instructions in the literature accompanying the equipment.

## 1. Preliminary Instructions

### • General Warnings

This equipment should only be operated, installed and maintained by "trained" or "qualified" personnel who are familiar with risks involved in working on electric and electronic circuits. "Trained" means personnel who have technical knowledge of equipment operation and who are responsible for their own safety and that of other unqualified personnel placed under their supervision when working on the equipment. "Qualified" means personnel who are trained in and experienced with equipment operation and who are responsible for their own safety and that of other unqualified personnel placed under their supervision when working on the equipment.

 **WARNING: Residual voltage may be present inside the equipment even when the ON/OFF switch is set to Off. Before servicing the equipment, disconnect the power cord or switch off the main power panel and make sure the safety earth connection is connected. Some service situations may require inspecting the equipment with live circuits. Only trained and qualified personnel may work on the equipment live and shall be assisted by a trained person who shall keep ready to disconnect power supply at need.**

**R.V.R. Elettronica SpA** shall not be liable for injury to persons or damage to property resulting from improper use or operation by trained/untrained and qualified/unqualified persons.

 **WARNING: The equipment is not water resistant. Any water entering the enclosure might impair proper operation. To prevent the risk of electrical shock or fire, do not expose this equipment to rain, dripping or moisture.**

Please observe local codes and fire prevention rules when installing and operating this equipment.

 **WARNING: This equipment contains exposed live parts involving an electrical shock hazard. Always disconnect power supply before removing any covers or other parts of the equipment.**

Ventilation slits and holes are provided to ensure reliable operation and prevent overheating; do not obstruct or cover these slits. Do not obstruct the ventilation slits under any circumstances. The product must not be incorporated in a rack unless adequate ventilation is provided or the manufacturer's instructions are followed closely.

 **WARNING: This equipment can radiate radiofrequency energy and, if not installed in compliance with manual instructions and applicable regulations, may cause interference with radio communications.**

 **WARNING: This equipment is fitted with earth connections both in the power cord and for the chassis. Make sure both are properly connected.**

Operation of this equipment in a residential area may cause radio interference, in which case the user may be required to take adequate measures.

The specifications and data contained herein are provided for information only and are subject to changes without prior notice. **R.V.R. Elettronica SpA** disclaims all warranties, express or implied. While **R.V.R. Elettronica SpA** attempts to provide accurate information, it cannot accept responsibility or liability for any errors or inaccuracies in this manual, including the products and the software described herein. **R.V.R. Elettronica SpA** reserves the right to make changes to equipment design and/or specifications and to this manual at any time without prior notice.

• **Notice concerning product intended purpose and use limitations.**

This product is a radio transmitter suitable for frequency-modulation audio radio broadcasting. Its operating frequencies are not harmonised in designated user countries. Before operating this equipment, user must obtain a licence to use radio spectrum from the competent authority in the designated user country. Operating frequency, transmitter power and other characteristics of the transmission system are subject to restrictions as specified in the licence.

## 2. Warranty

La **R.V.R. Elettronica S.P.A.** warrants this product to be free from defects in workmanship and its proper operation subject to the limitations set forth in the supplied Terms and Conditions. Please read the Terms and Conditions carefully, as purchase of the product or acceptance of the order acknowledgement imply acceptance of the Terms and Conditions. For the latest updated terms and conditions, please visit our web site at [WWW.RVR.IT](http://WWW.RVR.IT). The web site may be modified, removed or updated for any reason whatsoever without prior notice. The warranty will become null and void in the event the product enclosure is opened, the product is physically damaged, is repaired by unauthorised persons or is used for purposes other than its intended use, as well as in the event of improper use, unauthorised changes or neglect. In the event a defect is found, follow this procedure:

1 Contact the seller or distributor who sold the equipment; provide a description of the problem or malfunction for the event a quick fix is available.

Sellers and Distributors can provide the necessary information to troubleshoot the most frequently encountered problems. Normally, Sellers and Distributors can offer a faster repair service than the Manufacturer would. Please note that Sellers can pinpoint problems due to wrong installation.

2 If your Seller cannot help you, contact **R.V.R. Elettronica** and describe the problem; if our staff deems it appropriate, you will receive an authorisation to return the equipment along with suitable instructions;

3 When you have received the authorisation, you may return the unit. Pack the unit carefully before shipment; use the original packaging whenever possible and seal the package perfectly. The customer bears all risks of loss (i.e., **R.V.R.** shall not be liable for loss or damage) until the package reaches the **R.V.R.** factory. For this

reason, we recommend insuring the goods for their full value. Returns must be sent on a C.I.F. basis (PREPAID) to the address stated on the authorisation as specified by the R.V.R. Service Manager.



Units returned without a return authorisation may be rejected and sent back to the sender.

- 4 Be sure to include a detailed report mentioning all problems you have found and copy of your original invoice (to show when the warranty period began) with the shipment.

Please send spare and warranty replacement parts orders to the address provided below. Make sure to specify equipment model and serial number, as well as part description and quantity.

R.V.R. Elettronica SpA  
Via del Fonditore, 2/2c  
40138 BOLOGNA ITALY  
Tel. +39 051 6010506

## 3. First Aid

All personnel engaged in equipment installation, operation and maintenance must be familiar with first aid procedures and routines.

### 3.1 Electric shock treatment

#### 3.1.1 If the victim is unconscious

Follow the first aid procedures outlined below.

- Lay the victim down on his/her back on a firm surface.
- the neck and tilt the head backwards to free the airway system (**Figure 1**).

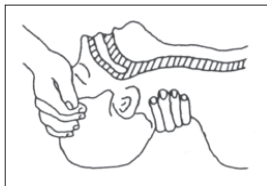

Figure 1

- If needed, open the victim's mouth and check for breathing.
- If there is no breathing, start artificial respiration without delay (**Figure 2**) as follows: tilt the head backwards, pinch the nostrils, seal your mouth around the victim's mouth and give four fast rescue breaths.



Figure 2

- Check for heartbeat (**Figure 3**); if there is no heartbeat, begin chest compressions immediately (**Figure 4**) placing your hands in the centre of the victim's chest (**Figure 5**).

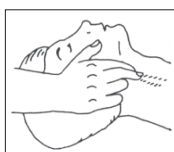

Figure 3

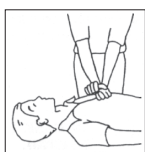

Figure 4

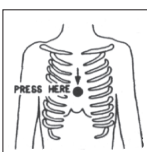

Figure 5

- One rescuer: give 2 quick rescue breaths after each 15 compressions.
- Two rescuers: one rescue breath after each 5 compressions.
- Do not stop chest compressions while giving artificial breathing.
- Call for medical help as soon as possible.

#### 3.1.2 If the victim is conscious

- Cover victim with a blanket.
- Try to reassure the victim.
- Loosen the victim's clothing and have him/her lie down.
- Call for medical help as soon as possible.

### 3.2 Treatment of electric burns

#### 3.2.1 Large burns and broken skin

- Cover affected area with a clean cloth or linen.
- Do not break any blisters that have formed; remove any clothing or fabric that is stuck to the skin; apply adequate ointment.
- Administer adequate treatment for the type of accident.
- Get the victim to a hospital as quickly as possible.
- Elevate arms and legs if injured.

If medical help is not available within an hour, the victim is conscious and is not retching, administer a solution of table salt and baking soda (one teaspoon of table salt to half teaspoon of baking soda every 250 ml of water).

Have the victim slowly drink half a glass of solution for four times during a period of 15 minutes.

Stop at the first sign of retching.

Do not administer alcoholic beverages.

#### 3.2.2 Minor burns

- Apply cold (not ice cold) strips of gauze or dress wound with clean cloth.
- Do not break any blisters that have formed; remove any clothing or fabric that is stuck to the skin; apply adequate ointment.
- If needed, have the victim change into clean, dry clothing.
- Administer adequate treatment for the type of accident.
- Get the victim to a hospital as quickly as possible.
- Elevate arms and legs if injured.

## 4. Unpacking

The package contains:

- 1 **SCML1+1SL**
- 1 User Manual
- 1 Mains power cable

The following accessories are also available from Your R.V.R. Dealer:

- **Accessories, spare parts and cables**

### 4.1 General Description

The new **SCML1+1SL** changeover family can be connected to all RVR standard equipment, as well with all kind of transmitting systems, and are characterized by:

- **SCML1+1SL/V1**: version with external Spinner relay mod. BN754067 and BN754098, for transmitters with output power range of 150W to 1000W:



- **SCML1+1SL/V2**: version with internal relay, for transmitters with output power lower than 150W:



- **SCML1+1SL/V3**: version with external Spinner relay mod. BN512690, BN640075 and BN941912, for transmitters with output power higher than 1000W:



- **SCML1+1SL/V4**: version with interface for customized external relay:



A clear and immediate representation of the working conditions through synoptic indication on the position of changeover.

Connection for the management of the main signals: Telecontrol (TC) and Telesignal (TS) are available on I/O interface.



## 5. Configurations

This section provides a description about the typical configurations and about the firmware of the equipment.

In the following figure is represented the dip-switches necessary to configure the SCML1+1SL in case of change in the system configuration.

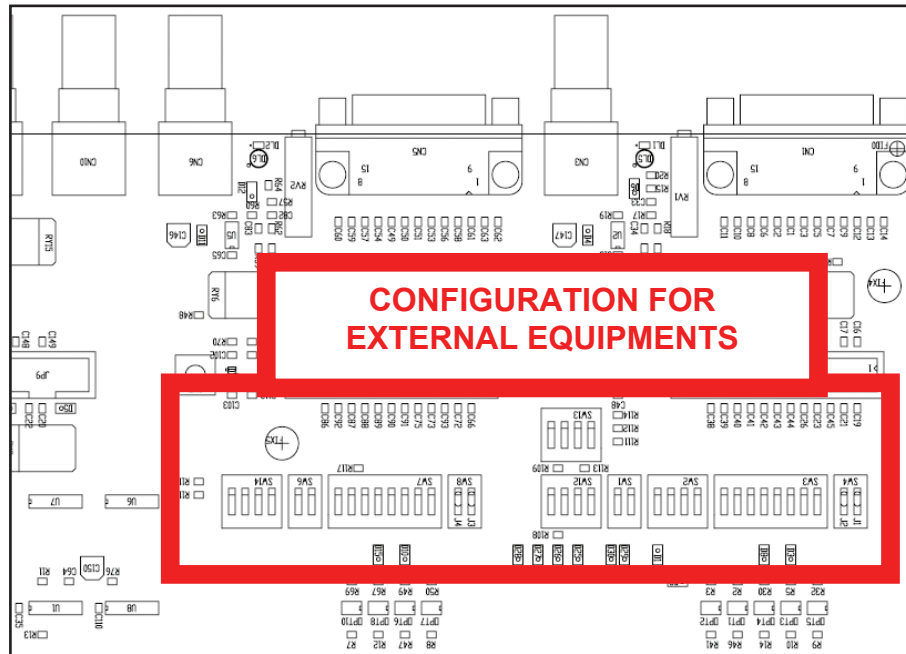

Figure 5.1: Dip-switch for external equipment configurations

### 5.1 Typical Configuration with Exciters of Tex and Blues family

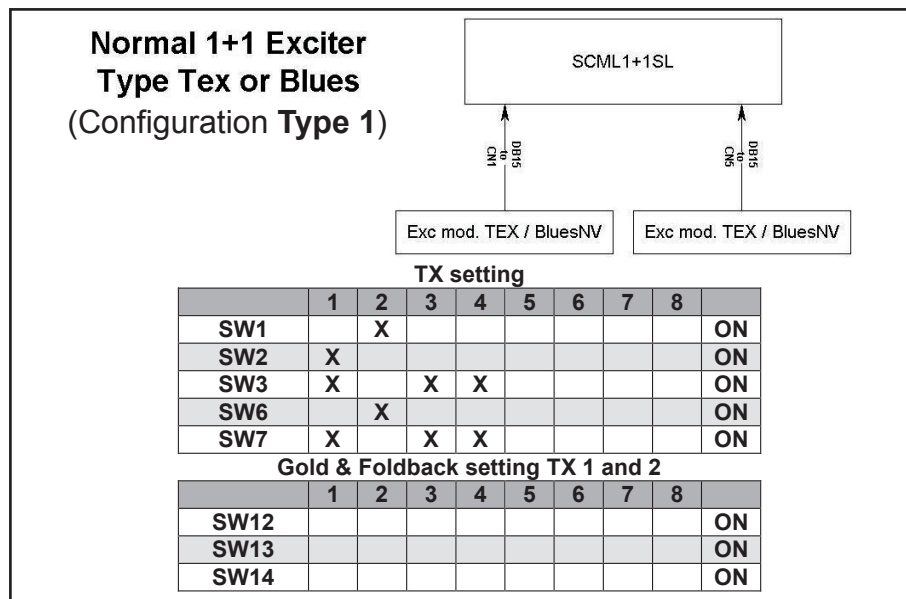

Figure 5.2: 1+1 system typical configuration for TEX or Blues Family



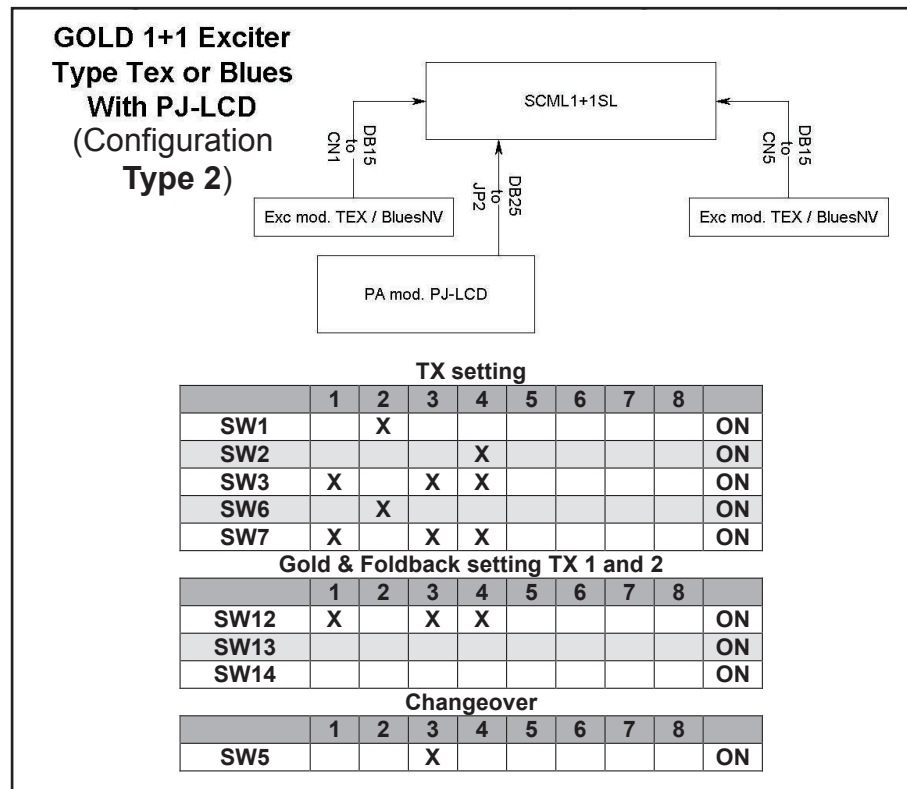

Figure 5.3: 1+1 GOLD system typical configuration for TEX or Blues and PJ-LCD

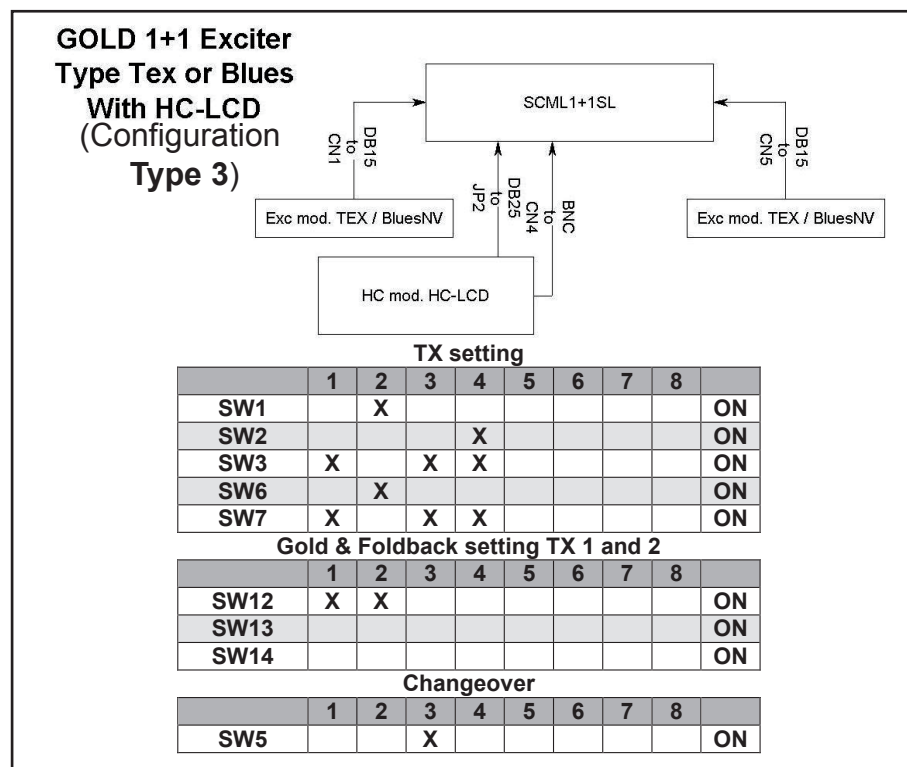

Figure 5.4: 1+1 GOLD system typical configuration for TEX or Blues and HC-LCD

## 5.2 Typical Configuration with Exciters of PTX family

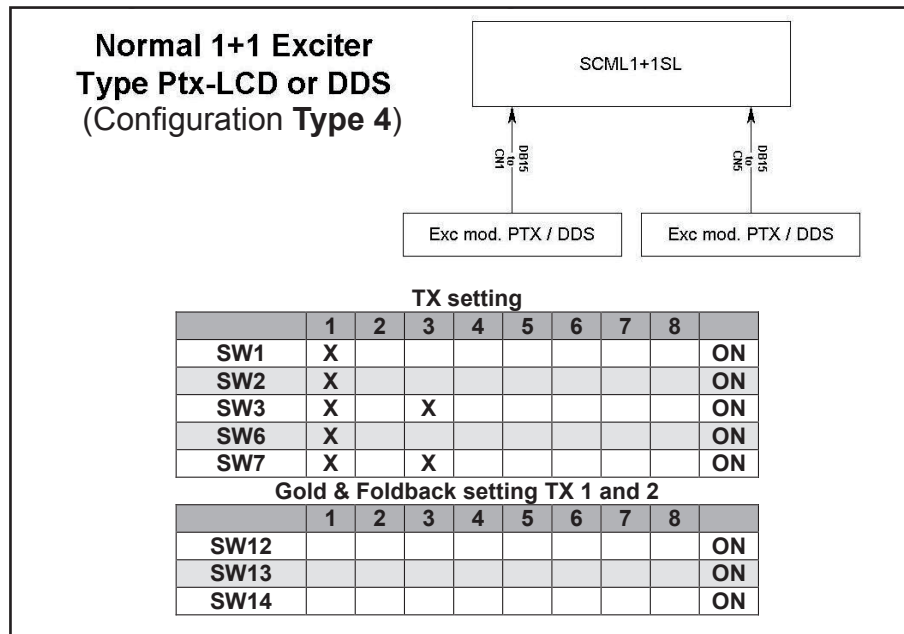

Figure 5.5: 1+1 system typical configuration for PTX LCD or DDS Family

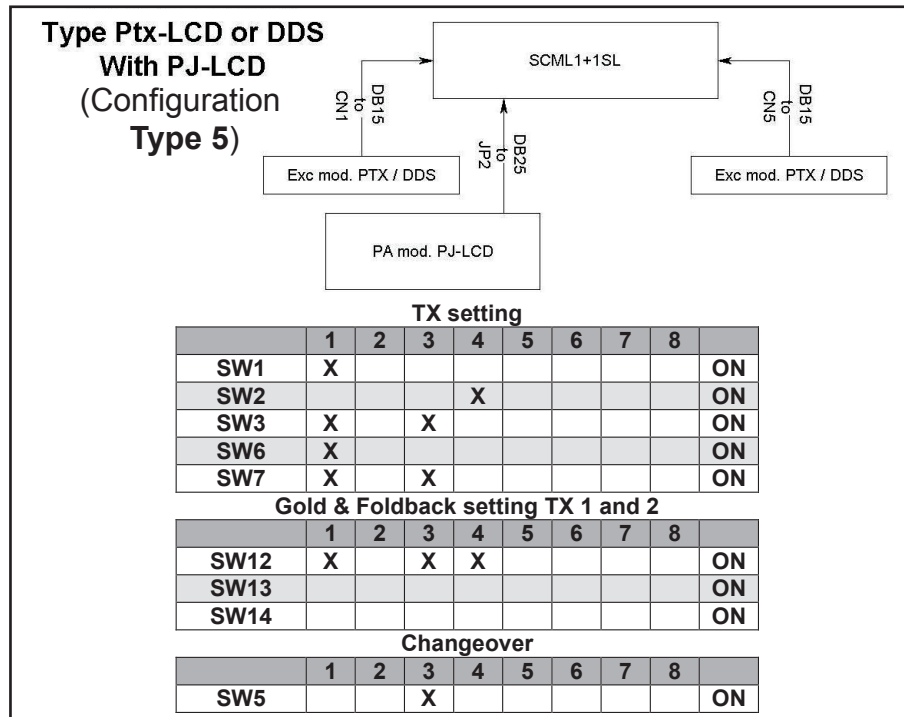

Figure 5.6: 1+1 GOLD system typical configuration for PTX LCD or DDS and PJ-LCD

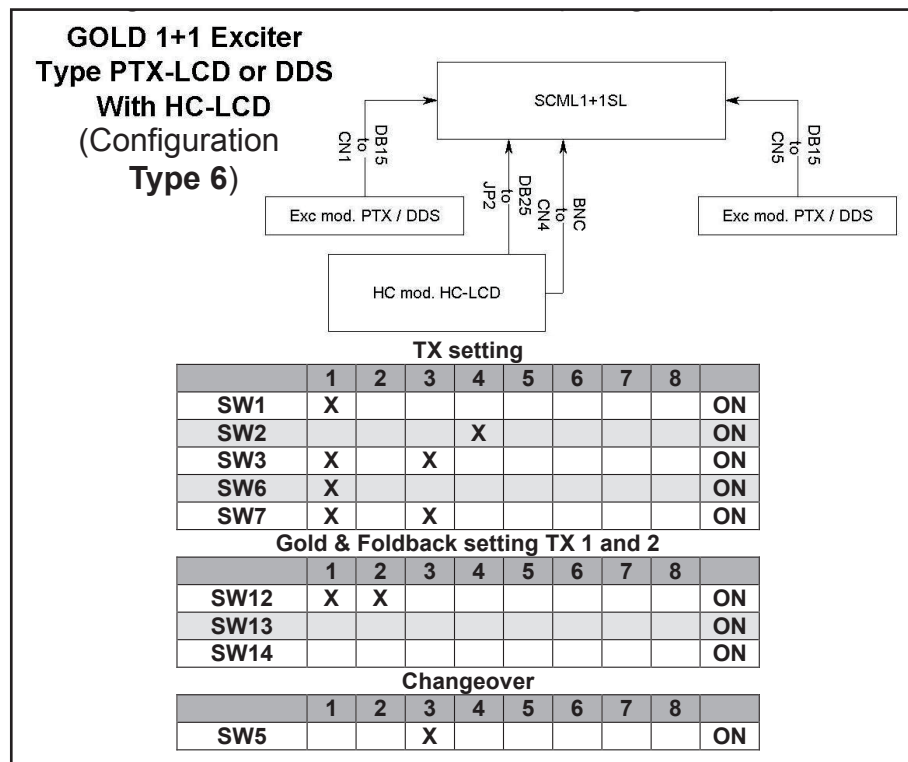

Figure 5.7: 1+1 GOLD system typical configuration for PTX LCD or DDS and HC-LCD

### 5.3 Typical Configuration with Mixed Exciters

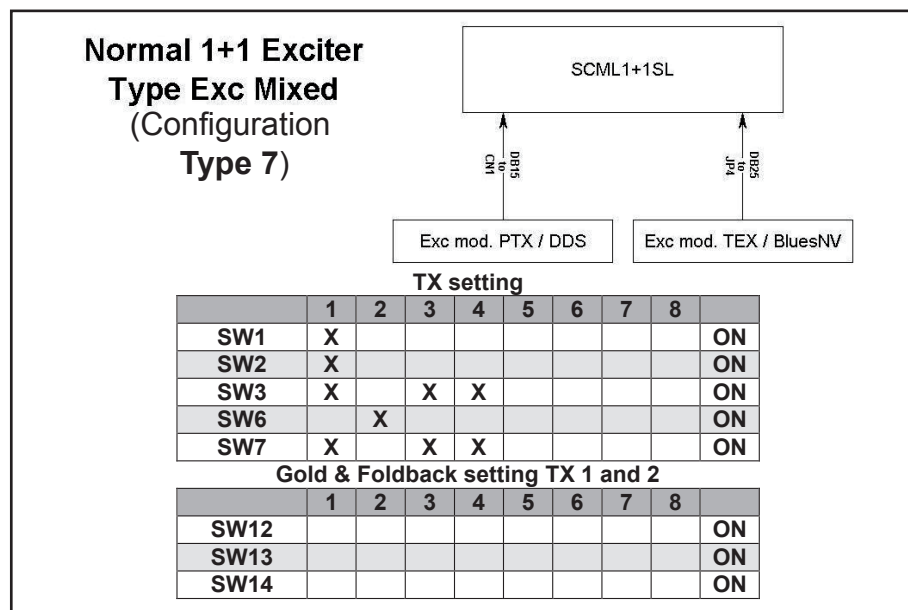

Figure 5.8: 1+1 system typical configuration for PTX LCD or DDS and TEX or Blues

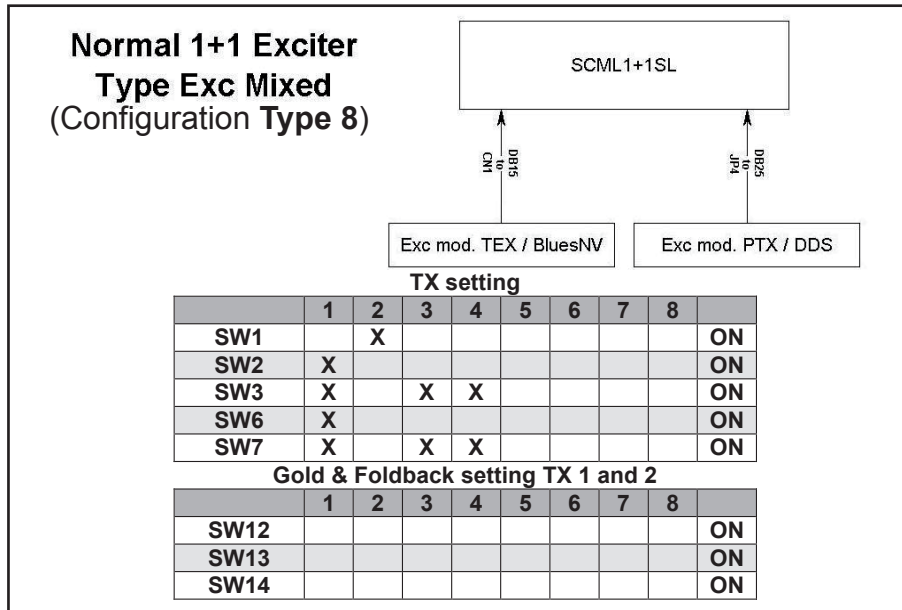

Figure 5.9: 1+1 system typical configuration for TEX or Blues and PTX LCD or DDS

### 5.4 Typical Configuration with Transmitting systems

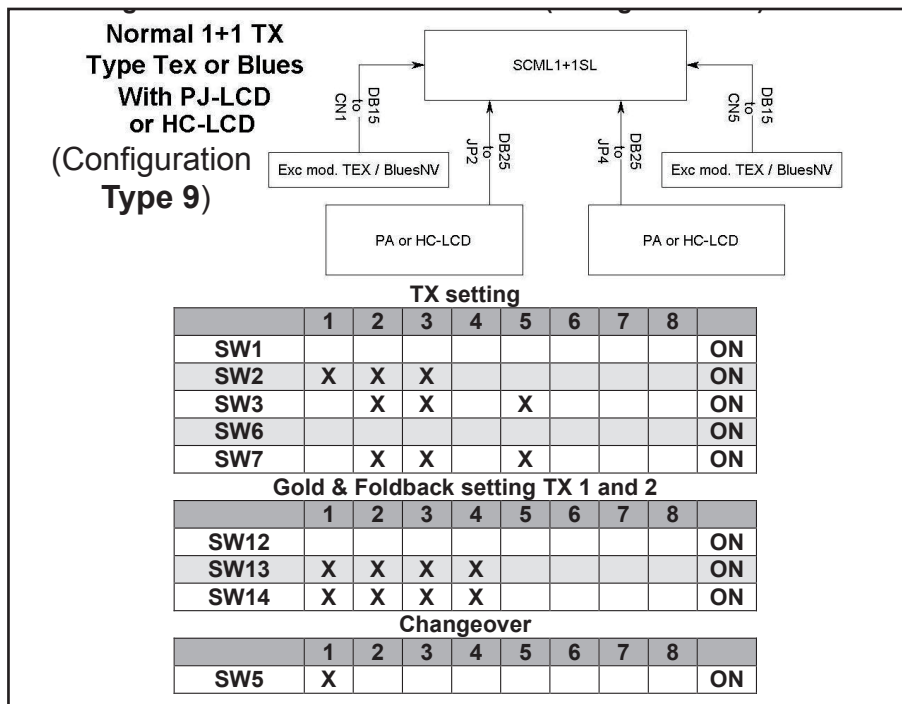

Figure 5.10: 1+1 TX system typical configuration for TEX or Blues and PJ-LCD or HC-LCD

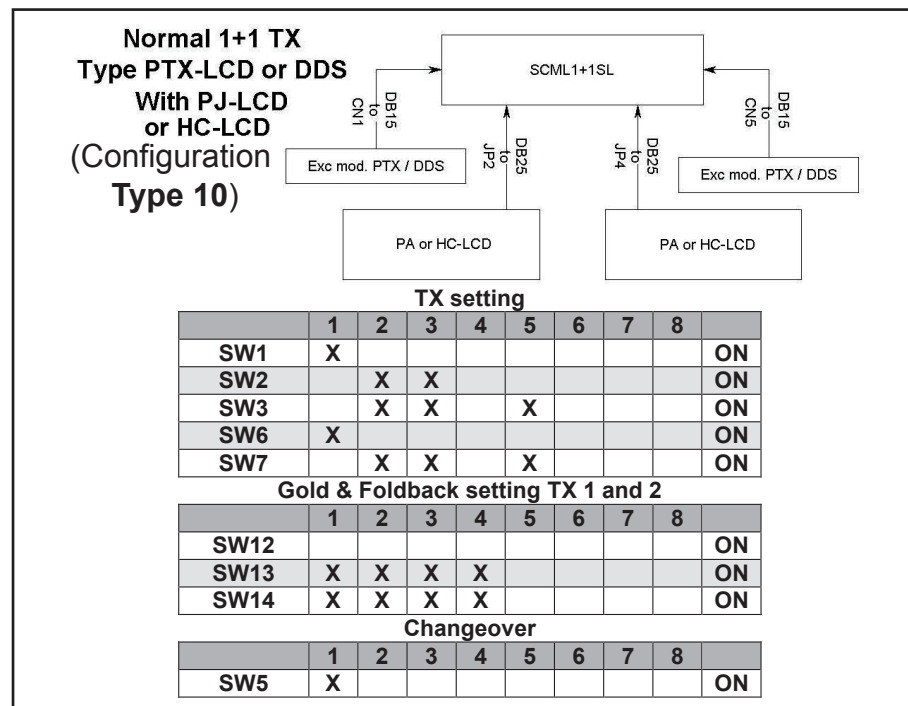

Figure 5.11: 1+1 TX system typical configuration for PTX LCD or DDS and PJ-LCD or HC-LCD

## 5.5 User Interface

The machine features an LCD with two lines by 16 characters that displays a set of menus.

The status of the machine is indicated by four LEDs located on the front panel: MANUAL, LOCAL, MAINS, ALARM and seven LED for synoptical signalling.

The interaction between the user and the exciter control software is performed using the encoder.

The operations that you can perform on the encoder are:

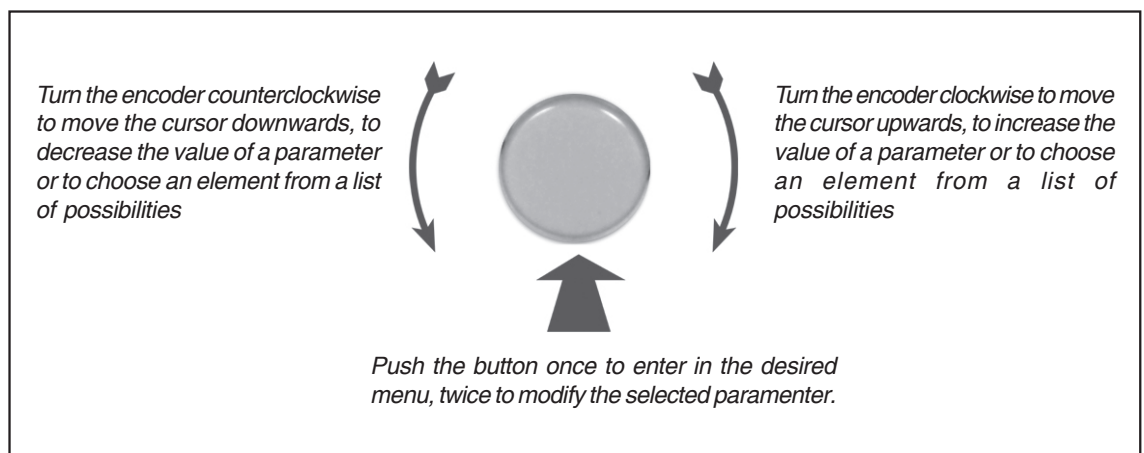

- **Rotation:** moves the cursor shows on the display; if you turn the encoder to the left (counter clockwise), the cursor moves downwards, if you turn it right the cursor

moves upwards; it also permits to increase or diminish the parameters (turning the encoder left diminishes the parameter).

- **Pushing:** push the button once when the cursor is on the name of a menu to enter in that menu, push it when the cursor is on the name of a parameter to enter in modification mode (the cursor starts blinking); after the modification of a parameter, push the button to save the new value.

After having modified the value of a parameter, the cursor goes on blinking for approximately 15 seconds, waiting for confirmation from the user. If the user doesn't confirm the new value (i.e., the button is not pressed), the parameter has not saved and remains on the selected parameter.



The first pressure of the ENCODER when the display is light out, or its rotation, serves in order to activate the retroillumination if disabled.

## 5.6 Management Firmware

The following is a representation of the main screen, available once you switch on the equipment or when after 180s the encoder is not used, and gives to the user information about the status of the system.

<p>TX1 : ON      TX2 : Off   Retry 05/10</p>
---

The main screen shows information regards the status of TX and the number of automatic retry, moreover is present an hourglass that indicates:

1. Start time presence, if is the only  icon present;
2. Exchange time presence, if the  icon is combined with  icon.

The  icon identifies a temporary suspension of the exchange automatism and appears when:

1. The SCM is in ALARM status.
2. One TX is in LOCAL condition.
3. The total number of Retry is 0.
4. The number of makes Retry is the same to the number of total Retry.
5. In Gold configuration the PA connected gives the interlock.

By pressing the encoder you see all the menu available, turning through the "►" symbol you can chooses it and by pressing you can access to its inside. After ~20s you return to the main screen in case the encoder is not used.

```
►General Setting
TX1      Setting
TX1      Setting
Change   Setting
Function Status
Soft.    Version
Exit
```

### 5.6.1 General Setting

```
TX1      : ON
TX2      : OFF
Change   : Normal
Func.    : AUTO
Mode     : REMOTE
Reset    : OK
IIC      : 10
Exit
```

- TX1 Enables (ON) or disables (OFF) the first transmitter.
- TX2 Enables (ON) or disables (OFF) the second transmitter.
- Change Forces the transmitter changeover
- Func. Selects the automatic or manual changeover.
- Mode Enables (REMOTE) or disables (LOCAL) the management from external commands
- Reset Sets at zero the retry counter retraining the changeover
- IIC Specifies the slave address of the equipment on IIC



## 5.6.2 TX1 Setting and TX2 Setting

```
PgMode: Analog
PowerG: Present
Power : Off
Status: Local
Exit
```

**PgMode** Identifies the modality of the power good state that can be selected from the voices: “Analog”, “Digital”, “AnIAud”, “DigAud”.

**PowerG** Identifies the power good state related to the transmitter filtered from firmware.

**Power** Command to power on or to power off the equipment.

**Status** Shows the status (LOCAL or REMOTE) of the equipment.

## 5.6.3 Change Setting

```
Retry : 10
Start :05m00s
Before:02m00s
TxOff :02m00s
Coax :02m00s
After :05m00s
Exit
```

**Retry** indicates the total number of retry before passing in MANUAL from 0 to 50.

**Start** modifies the waiting time to the start from 5 to 60 min.

**Before** modifies the waiting time before beginning the exchange from 1 sec to 30 min.

**TXOff** modifies the waiting time before beginning the switch off of TX from 1 sec to 30 min.

**Coax** modifies the waiting time before beginning the commutation of the coaxial relay from 5 sec to 30 min.

**After** modifies the waiting time before beginning the switch on of TX in antenna from 5 sec to 30 min.

### 5.6.4 Function Status

```
Load   : Fault
L-Fan  : On
InhPa  : Disable
IntAud : Normal
ExtAud : Disable
Exit
```

Load shows the dummy load status (if enabled).

L-Fan shows the status of the fan on the dummy load (if enabled).

InhPa shows the status of the inhibit signal supplied from the PA in the Gold configuration (if enabled)

IntAud shows the status of the internal audio exchange.

ExtAud shows the status of the external audio exchange (if enabled).

### 5.6.5 Software Version

```
Rel : 01010000
Dat : gg/mm/aaaa
Tab : SL1-Test-01
Exit
```

Rel shows the firmware release information.

Dat shows the release date.

Tab shows the table code programmed as default.

## 6. External Description

This chapter reports the elements of the front and rear panels of the **SCML1+1SL** with a brief description of each of them.

### 6.1 Front Panel

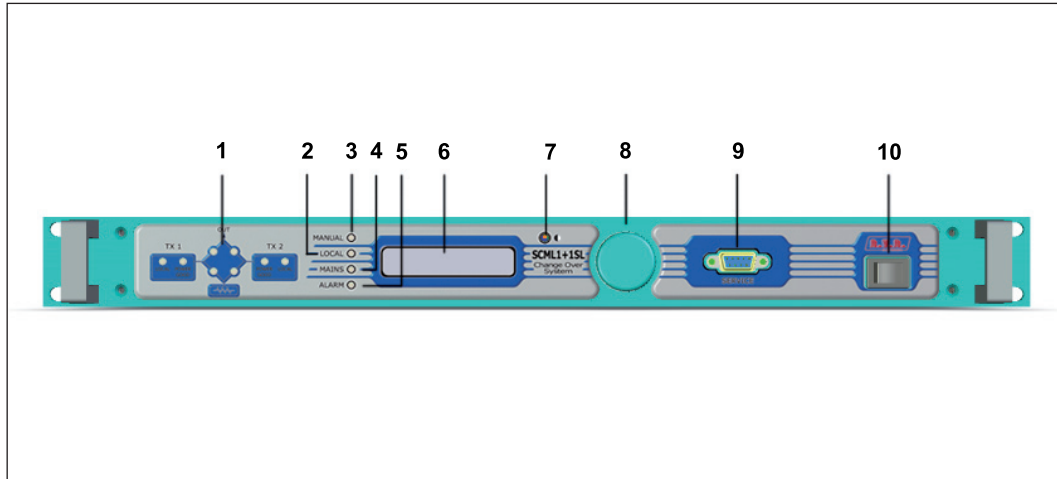

Figure 6.1

- |              |   |
|--------------|---|
| [1] SYNOPTIC | Series of LED for the instantaneous vision of the exchange condition. Shows the position of coaxial relay, the state of dummy load and of transmitter connects to it.             |
| [2] MANUAL   | Yellow LED, lit when the change-over is set up in order to allow the control exclusively from the customer, inhibiting the automatic management of the equipment functionalities. |
| [3] LOCAL    | Yellow LED, lit when the change-over is set up in order to receive controls exclusively from the encoder, inhibiting any source of telecontrol.                                   |
| [4] MAINS    | Yellow LED, lit when the change-over is supplied at 24V.  |
| [5] ALARM    | Red LED, lit when the change-over has had problems during the phase of exchange between the two transmitters.   |
| [6] DISPLAY  | Liquid crystals display (2 rows, 16 characters).  |
| [7] CONTRAST | Display contrast adjusting trimmer.   |
| [8] ENCODER  | Knob and button in order to software control.   |
| [9] SERVICE  | DB9 connector for factory parameters programming (cap. 6.6.3).  |
| [10] POWER   | Mains switch.   |

## 6.2 Rear Panel SCML1+1SL/V1

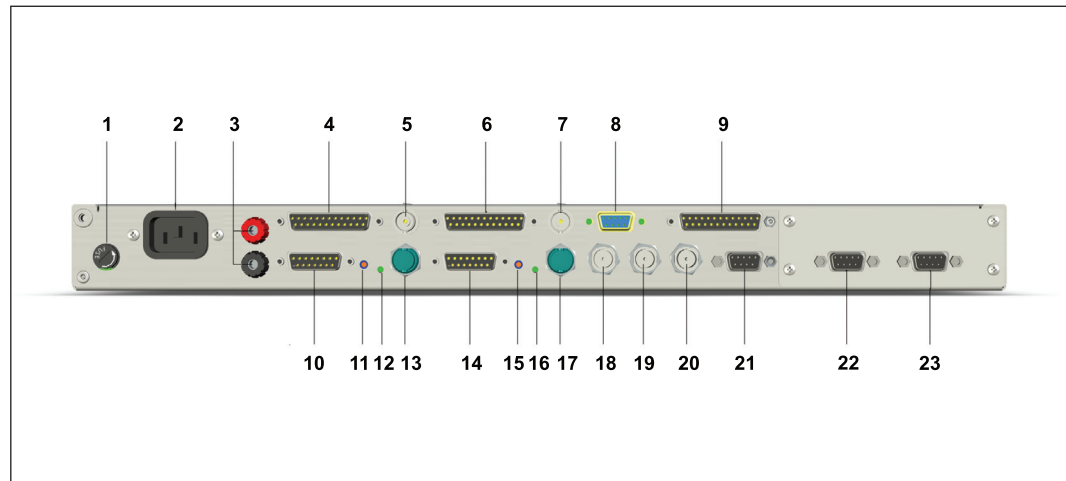

Figure 6.2

- |                           |  |
|---------------------------|--|
| [1] MAIN FUSE T1.6        | Fuse carrier for the fuse (1.6AT 5x20) for mains supply.   |
| [2] MAINS VOLTAGE         | Standard IEC connector for mains supply 110 ÷ 230 V, +10/-15%.   |
| [3] 24VDC                 | Socket for 24Vdc external power supply.  |
| [4] PA1 /HC               | DB25 connector, for input of TELEMETRY connector coming from an (i.e.: PJ2000M-C) or an hybrid coupler (i.e.:HC2/2) del TX1. |
| [5] ANALOG IN or FOLDBACK | BNC connector, for the acquisition of an RF signal < 10dBm coming from an RF TEST or for the foldback signal of TX1.         |
| [6] PA2                   | DB25 connector, for input of TELEMETRY connector coming from an (i.e.: PJ2000M-C) of TX2.                                    |
| [7] ANALOG IN             | BNC connector, for the acquisition of an RF signal < 10dBm coming from an RF TEST of TX1.                                    |
| [8] I <sup>2</sup> C      | DB9 connector for I <sup>2</sup> C bus network (cap. 6.6.2).   |
| [9] TC / TS               | DB25 connector, for the management of main signals of telecontrol and telelabelling (cap. 6.6.1).                            |
| [10] EXC1                 | DB15 connector, for input of REMOTE connector coming from an exciter (i.e.: BLUES30NV) of TX1.                               |
| [11] ADJ                  | Trimmer for intervention level adjustment on ANALOG IN signal [5].   |
| [12] PWR GOOD             | Green Led, lit when the Power Good threshold is passed.  |
| [13] INTERLOCK            | BNC connector, for the interlock signal coming from transmitter system TX1.  |
| [14] EXC2                 | DB15 connector, for input of REMOTE connector coming from an exciter (i.e.: BLUES30NV) of TX2.                               |
| [15] ADJ                  | Trimmer for intervention level adjustment on ANALOG IN signal [7].   |
| [16] PWR GOOD             | Green Led, lit when the Power Good threshold is passed.  |
| [17] INTERLOCK            | BNC connector, for the interlock signal coming from transmitter system TX2.  |
| [18] IN/OUT1              | BNC connector, for audio input or output of TX1.   |
| [19] COMMON               | BNC connector, for audio output or input of common channel.  |
| [20] IN/OUT2              | BNC connector, for audio input or output of TX2.   |
| [21] EXT SCM AUD          | DB9 connector, interface for external audio changeover.  |
| [22] COAX RELAY           | DB9 connector, for inteconnection with Spinner coaxial relay models BN754067 and BN754098.                                   |
| [23] DUMMY LOAD           | DB9 connector, for interconnection with dummy load (cap. 6.6.5).   |

## 6.3 Rear Panel SCML1+1SL/V2

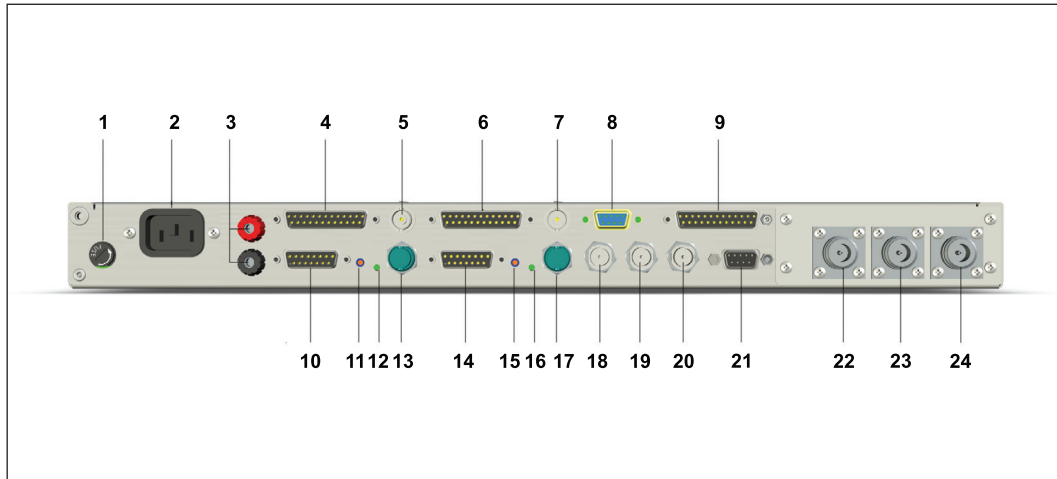

Figure 6.3

- [1] MAIN FUSE T1.6  
Fuse carrier for the fuse (1.6AT 5x20) for mains supply.
- [2] MAINS VOLTAGE  
Standard IEC connector for mains supply 110 ÷ 230 V, +10/-15%.
- [3] 24VDC  
Socket for 24Vdc external power supply.
- [4] PA1 /HC  
DB25 connector, for input of TELEMETRY connector coming from an (i.e.: PJ2000M-C) or an hybrid coupler (i.e.:HC2/2) del TX1.
- [5] ANALOG IN or FOLDBACK  
BNC connector, for the acquisition of an RF signal < 10dBm coming from an RF TEST or for the foldback signal of TX1.
- [6] PA2  
DB25 connector, for input of TELEMETRY connector coming from an (i.e.: PJ2000M-C) of TX2.
- [7] ANALOG IN  
BNC connector, for the acquisition of an RF signal < 10dBm coming from an RF TEST of TX1.
- [8] I<sup>2</sup>C  
DB9 connector for I<sup>2</sup>C bus network (cap. 6.6.2).
- [9] TC / TS  
DB25 connector, for the management of main signals of telecontrol and telelabelling (cap. 6.6.1).
- [10] EXC1  
DB15 connector, for input of REMOTE connector coming from an exciter (i.e.: BLUES30NV) of TX1.
- [11] ADJ  
Trimmer for intervention level adjustment on ANALOG IN signal [5].
- [12] PWR GOOD  
Green Led, lit when the Power Good threshold is passed.
- [13] INTERLOCK  
BNC connector, for the interlock signal coming from transmitter system TX1.
- [14] EXC2  
DB15 connector, for input of REMOTE connector coming from an exciter (i.e.: BLUES30NV) of TX2.
- [15] ADJ  
Trimmer for intervention level adjustment on ANALOG IN signal [7].
- [16] PWR GOOD  
Green Led, lit when the Power Good threshold is passed.
- [17] INTERLOCK  
BNC connector, for the interlock signal coming from transmitter system TX2.
- [18] IN/OUT1  
BNC connector, for audio input or output of TX1.
- [19] COMMON  
BNC connector, for audio output or input of common channel.
- [20] IN/OUT2  
BNC connector, for audio input or output of TX2.
- [21] EXT SCM AUD  
DB9 connector, interface for external audio changeover.
- [22] ANT  
N-type connector, for RF output toward antenna.
- [23] TX1  
N-type connector, for RF input coming from TX1.
- [24] TX2  
N-type connector, for RF input coming from TX2.

## 6.4 Rear Panel SCML1+1SL/V3

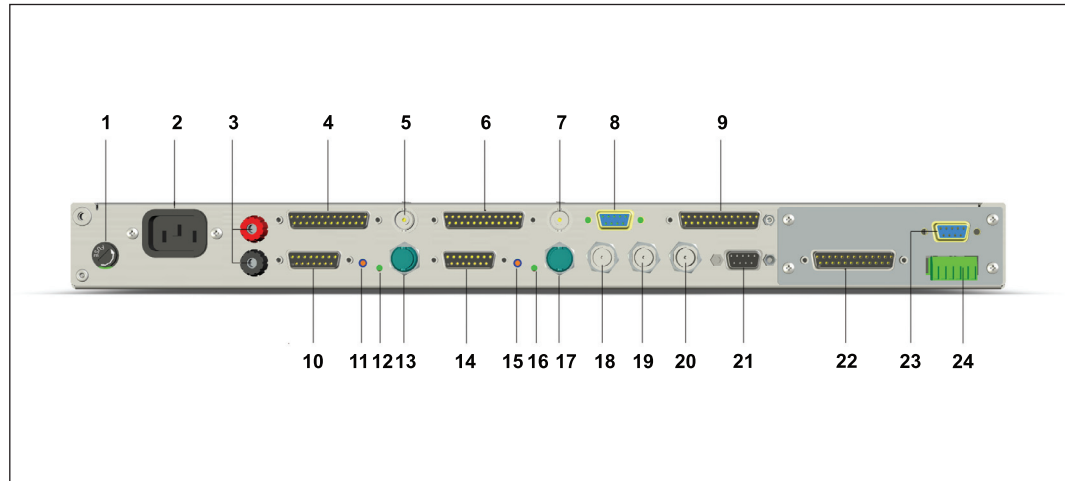

Figure 6.4

- |                           |  |
|---------------------------|--|
| [1] MAIN FUSE T1.6        | Fuse carrier for the fuse (1.6AT 5x20) for mains supply.   |
| [2] MAINS VOLTAGE         | Standard IEC connector for mains supply 110 ÷ 230 V, +10/-15%.   |
| [3] 24VDC                 | Socket for 24Vdc external power supply.  |
| [4] PA1 /HC               | DB25 connector, for input of TELEMETRY connector coming from an (i.e.: PJ2000M-C) or an hybrid coupler (i.e.:HC2/2) del TX1. |
| [5] ANALOG IN or FOLDBACK | BNC connector, for the acquisition of an RF signal < 10dBm coming from an RF TEST or for the foldback signal of TX1.         |
| [6] PA2                   | DB25 connector, for input of TELEMETRY connector coming from an (i.e.: PJ2000M-C) of TX2.                                    |
| [7] ANALOG IN             | BNC connector, for the acquisition of an RF signal < 10dBm coming from an RF TEST of TX1.                                    |
| [8] I <sup>2</sup> C      | DB9 connector for I <sup>2</sup> C bus network (cap. 6.6.2).   |
| [9] TC / TS               | DB25 connector, for the management of main signals of telecontrol and telesignalling (cap. 6.6.1).                           |
| [10] EXC1                 | DB15 connector, for input of REMOTE connector coming from an exciter (i.e.: BLUES30NV) of TX1.                               |
| [11] ADJ                  | Trimmer for intervention level adjustment on ANALOG IN signal [5].   |
| [12] PWR GOOD             | Green Led, lit when the Power Good threshold is passed.  |
| [13] INTERLOCK            | BNC connector, for the interlock signal coming from transmitter system TX1.  |
| [14] EXC2                 | DB15 connector, for input of REMOTE connector coming from an exciter (i.e.: BLUES30NV) of TX2.                               |
| [15] ADJ                  | Trimmer for intervention level adjustment on ANALOG IN signal [7].   |
| [16] PWR GOOD             | Green Led, lit when the Power Good threshold is passed.  |
| [17] INTERLOCK            | BNC connector, for the interlock signal coming from transmitter system TX2.  |
| [18] IN/OUT1              | BNC connector, for audio input or output of TX1.   |
| [19] COMMON               | BNC connector, for audio output or input of common channel.  |
| [20] IN/OUT2              | BNC connector, for audio input or output of TX2.   |
| [21] EXT SCM AUD          | DB9 connector, interface for external audio changeover.  |
| [22] COAX RELAY           | DB9 connector, for inteconnection with Spinner coaxial relay models BN512690, BN640075 and BN941912.                         |
| [23] DUMMY LOAD           | DB9 connector, for interconnection with dummy load (cap. 6.6.5).   |
| [24] COAX OFF POSITION    | Phoenix connector, with out position contacts.   |

## 6.5 Rear Panel SCML1+1SL/V4

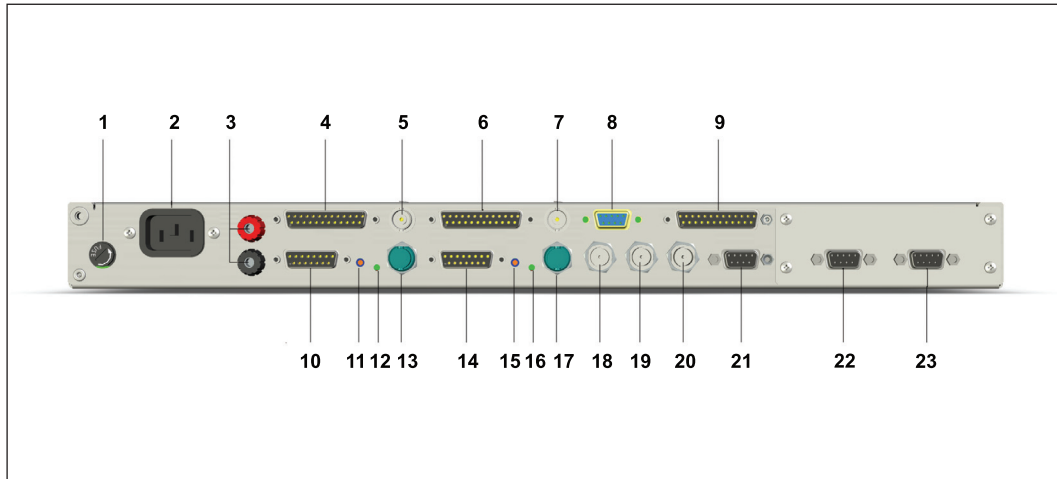

Figure 6.5

- [1] MAIN FUSE T1.6  
Fuse carrier for the fuse (1.6AT 5x20) for mains supply.
- [2] MAINS VOLTAGE  
Standard IEC connector for mains supply 110 ÷ 230 V, +10/-15%.
- [3] 24VDC  
Socket for 24Vdc external power supply.
- [4] PA1 /HC  
DB25 connector, for input of TELEMETRY connector coming from an (i.e.: PJ2000M-C) or an hybrid coupler (i.e.:HC2/2) del TX1.
- [5] ANALOG IN or FOLDBACK  
BNC connector, for the acquisition of an RF signal < 10dBm coming from an RF TEST or for the foldback signal of TX1.
- [6] PA2  
DB25 connector, for input of TELEMETRY connector coming from an (i.e.: PJ2000M-C) of TX2.
- [7] ANALOG IN  
BNC connector, for the acquisition of an RF signal < 10dBm coming from an RF TEST of TX1.
- [8] I2C  
DB9 connector for I2C bus network (cap. 6.6.2).
- [9] TC / TS  
DB25 connector, for the management of main signals of telecontrol and telelabelling (cap. 6.6.1).
- [10] EXC1  
DB15 connector, for input of REMOTE connector coming from an exciter (i.e.: BLUES30NV) of TX1.
- [11] ADJ  
Trimmer for intervention level adjustment on ANALOG IN signal [5].
- [12] PWR GOOD  
Green Led, lit when the Power Good threshold is passed.
- [13] INTERLOCK  
BNC connector, for the interlock signal coming from transmitter system TX1.
- [14] EXC2  
DB15 connector, for input of REMOTE connector coming from an exciter (i.e.: BLUES30NV) of TX2.
- [15] ADJ  
Trimmer for intervention level adjustment on ANALOG IN signal [7].
- [16] PWR GOOD  
Green Led, lit when the Power Good threshold is passed.
- [17] INTERLOCK  
BNC connector, for the interlock signal coming from transmitter system TX2.
- [18] IN/OUT1  
BNC connector, for audio input or output of TX1.
- [19] COMMON  
BNC connector, for audio output or input of common channel.
- [20] IN/OUT2  
BNC connector, for audio input or output of TX2.
- [21] EXT SCM AUD  
DB9 connector, interface for external audio changeover.
- [22] COAX RELAY  
DB9 connector, for link with external Interconnection Box Esterna (cap. 6.6.4).
- [23] DUMMY LOAD  
DB9 connector, for interconnection with dummy load (cap. 6.6.5).



## 6.6 Connectors Description

### 6.6.1 Remote

Type: Female DB25

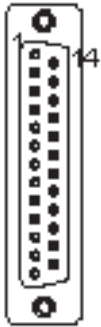

Pin	Name
1	+15V
2	+15V
3	TX1 Antenna (TC)
4	TX2 Antenna (TC)
5	TX1 ON (TC)
6	TX1 OFF (TC)
7	TX2 ON (TC)
8	TX2 OFF (TC)
9	AUTO (TC)
10	MANUAL (TC)
11	RESET (TC)
12	COMMON (TC)
13	GND
14	COMMON (TS)
15	TX1 Antenna (TS)
16	TX2 Antenna (TS)
17	TX1 OFF (TS)
18	TX1 ON (TS)
19	TX2 OFF (TS)
20	TX2 ON (TS)
21	MANUAL (TS)
22	AUTO (TS)
23	LOCAL (TS)
24	REMOTE (TS)
25	COMMON (TS)

### 6.6.2 I<sup>2</sup>C Bus

Type: Female DB9



1	NC
2	SDA
3	SCL
4	NC
5	GND
6	Reserved
7	Reserved
8	NC
9	NC

## 6.6.3 Service (only for factory setting purposes)

Type: Female DB9

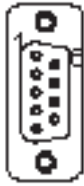

- 1 NC
- 2 TX\_D
- 3 RX\_D
- 4 Internally connected with 6
- 5 GND
- 6 Internally connected with 4
- 7 Internally connected with 8
- 8 Internally connected with 7
- 9 NC

## 6.6.4 Coax Relay (only for SCML1+1SL/V4)

Type: Female DB9



- 1 Control voltage (+)
- 2 Control voltage (-)
- 3 Relay in position 1 (OFF)
- 4 Relay in position 2 (ON)
- 5 GND
- 6 Switching to position 2 / NO
- 7 Switching to position 1 / NC
- 8 Common (when selected)
- 9 Relay Switching

Pins 1 and 2 are outputs on which the relay control voltage is made available (12V or 24V DC).

Connected to pins 3 and 4 are the relay limit switches, two contacts which alternately close towards the ground when the relay is in the normal position (TX1 connected to antenna, pin 3 closed to ground) or switched (TX2 connected to antenna, pin 4 closed to ground).

Pins 6 and 7 are the commands which cause the coaxial relay to switch from the normal position (Off) to the switched position (On) and vice versa; the type of command depends on the coaxial relay used, as well as the connecting cable between the SCM and the coaxial relay.

One of the possible positions of the control mode selection jumper makes available on pin 8 the common contact of a switch, of which pin 6 is the normally open (NO) contact and pin 7 is the normally closed (NC) contact.

Pin 9 is an open contact until switching begins, and is closed to ground when the relay has reached the new position.

### 6.6.5 Dummy Load

Type: Female DB9

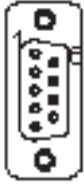

- 1 Relay (24V / 0,5A) for the fan control of the dummy load / NO
- 2 Relay (24V / 0,5A) for the fan control of the dummy load / C
- 3 Relay (24V / 0,5A) for the fan control of the dummy load / NC
- 4 +15V
- 5 GND
- 6 Input<sup>(1)</sup> for the Fault control of the dummy load (temperature) +/-
- 7 Input<sup>(1)</sup> for the Fault control of the dummy load (temperature) +/-
- 8 Not Connected
- 9 Not connected

<sup>(1)</sup>: An optoinsulator can be present between pin 6 and 7 as alternative.

## 7. Technical Specifications

### 7.1 Electrical characteristics

#### Generals

AC Power supply	110÷230 V +10/-15%, full range
DC Power supply	24V
Weight	About 6.5 kg (depends on the version)
Dimension	1 unit 19" rackmounted ( 483 x 44 x 390 mm)
Operating temperature	-10° C to +50° C
Maximum relative humidity	95%, without condensing

#### Inputs

TX1 / TX2	2x 15 pin sub-D connector for interconnection with RVR exciters
TX1 PA / TX2 PA	2x 25 pin sub-D connector for interconnection with RVR Power Amplifier or Hybrid Coupler
ANALOG IN	2x BNC unbalanced for interconnection with equipment non-RVR
IN/OUT	BNC unbalanced. MPX input for changeover

#### Outputs

Ext Audio	9 pin sub-D connector for external audio changeover
TX1 MPX / TX2 MPX	2x BNC unbalanced. MPX output for TX1 and TX2 transmitters
Interlock	2x BNC unbalanced to inhibit the exciter in changeover

#### Interface

I2C Bus	9 pin sub-D connector for I2C bus networking
TC/TS	25 pin sub-D connector for telecontrol and tele signal

#### Versions

V1	Version with external relay (N-type connector from 150W up to 1000W)
V2	Version with internal relay (N-type connector up to 150W)
V3	Version with external relay (7/16", 7/8" or 1+5/8" connectors over 1000W)
V4	Version with external customized relay

#### Software times

Base of times	~ 10 ms
Base of the times for the timer	~ 100 ms
Δt before entering in the main cycle to the start	~ 450 ms

---

Main cycle	~ 3 ms
Display Updating	~ 27 ms
Minimum lenght of a pulse referred to TxOn and TxOff relays	~ 300 ms

---

## 8. Internal Description

Following is a brief description of the different boards included in each changeover version.

### 8.1 SCML1+1SL/V1

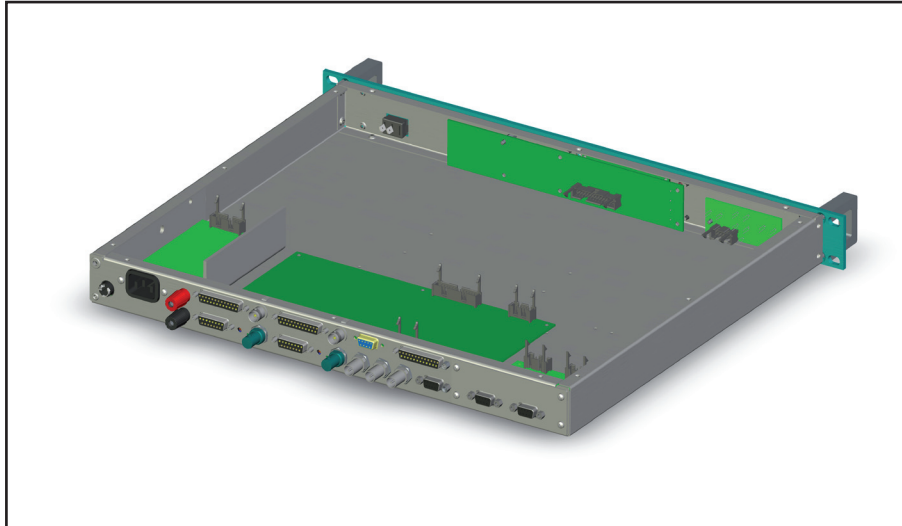

- SL125MA1002 (Main Board)
- SL125PC1001 (Synoptic Panel Board)
- SL125PC2001 (Panel Board)
- FLYRXRL1U (Power Supply)
- SL125IN2001 (DB9 External Relay Interface)

## 8.2 SCML1+1SL/V2

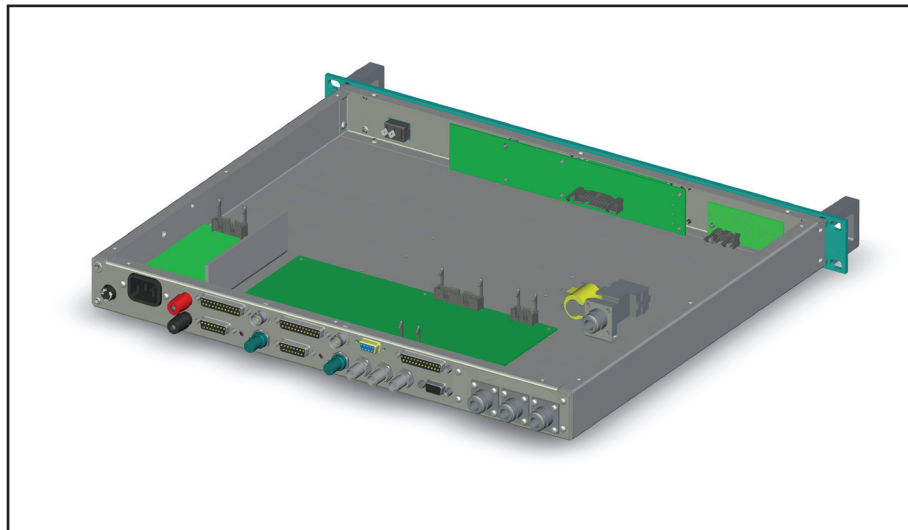

- SL125MA1002 (Main Board)
- SL125PC1001 (Synoptic Panel Board)
- SL125PC2001 (Panel Board)
- FLYRXRL1U (Power Supply)
- Internal Coaxial Relay



## 8.3 SCML1+1SL/V3

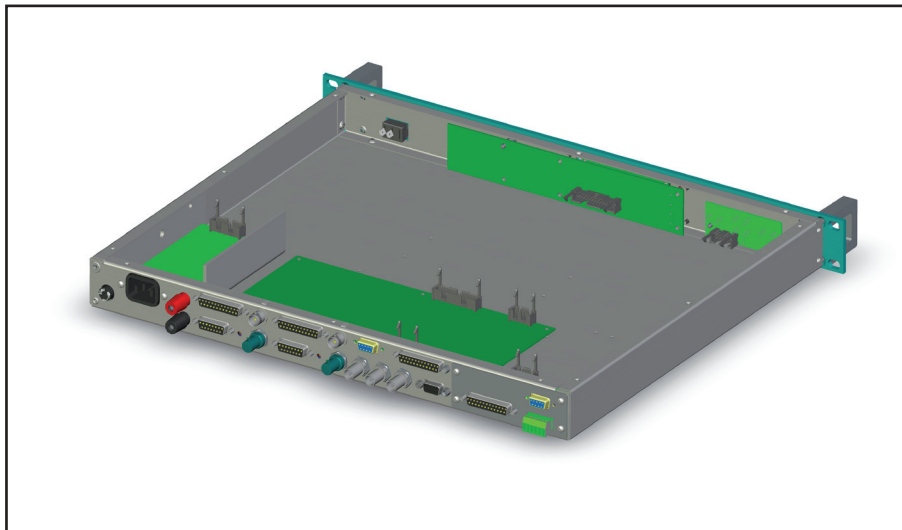

- SL125MA1002 (Main Board)
- SL125PC1001 (Synoptic Panel Board)
- SL125PC2001 (Panel Board)
- FLYRXRL1U (Power Supply)
- SL125IN1001 (DB25 External Relay Interface)

## 8.4 SCML1+1SL/V4

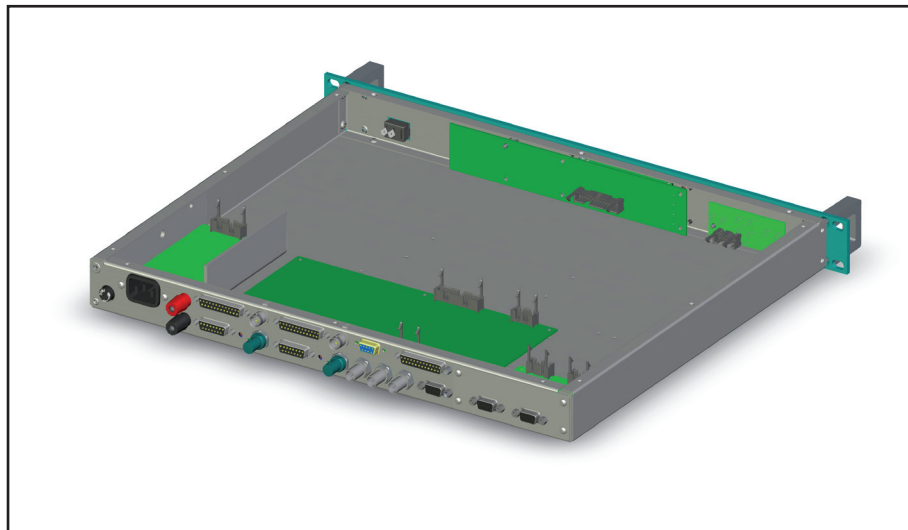

- SL125MA1002 (Main Board)
- SL125PC1001 (Synoptic Panel Board)
- SL125PC2001 (Panel Board)
- FLYRXRL1U (Power Supply)
- SL125IN2001 (DB9 External Relay Interface)

## 9. TC/TS Electromechanical Interface

In the following, there is a brief and schematic description in case you want to connect the I/O connector to external devices to use telecontrol (TC) and telesignalling (TS) functionality.

DB25	TYPE	DESCRIPTION	PIN
	POWER SUPPLY	+15 V	1 & 2
		GND	13
	INPUT (TC)	TX1 ON	5
		TX1 OFF	6
		TX2 ON	7
		TX2 OFF	8
		TX1 ANTENNA	3
		TX2 ANTENNA	4
		AUTO	9
		MANUAL	10
		RESET	11
		COMMON	12
	OUTPUT (TS)	TX1 ON	18
		TX1 OFF	17
		TX2 ON	20
		TX2 OFF	19
		TX1 ANTENNA	15
		TX2 ANTENNA	16
		AUTO	22
		MANUAL	21
		LOCAL	22
		REMOTE	24
		COMMON	14 & 25

Table of inputs and outputs of TC/TS electromechanical interface

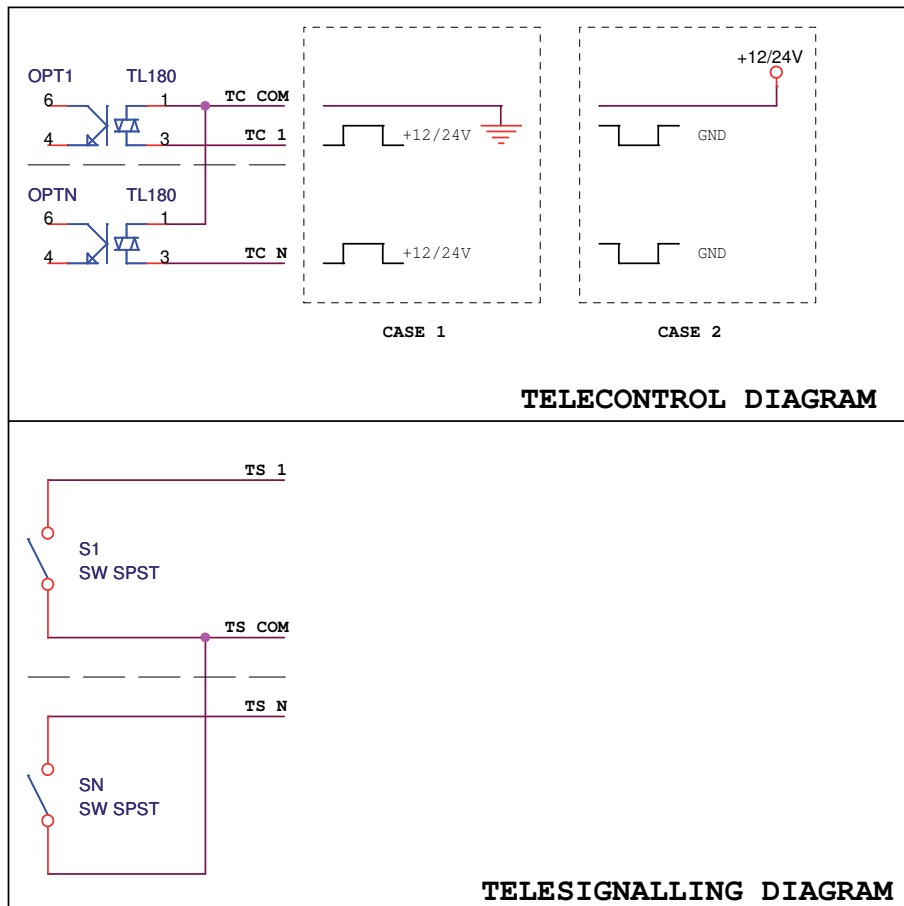

Schematic representation of TC/TS electromechanical interface operation