

PTRL-NV/S3

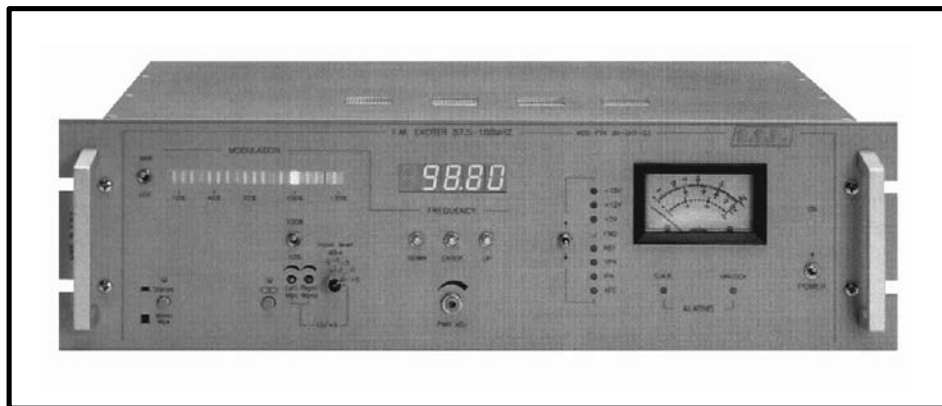

TECHNICAL AND MAINTENANCE MANUAL
MANUALE TECNICO EDI MANUIENZIONE



Manufactured by R.V.R. Elettronica - Italy

PTRLNV/S3
Stereo Studio Transmitter
Link 200/1100 MHz
Technical and Maintenance Manual
Manuale Tecnico e di Manutenzione

English

Pag. 3



Notification of intended purpose and limitations of product use

This product is a FM transmitter intended for FM audio broadcasting. It utilises operating frequencies not harmonised in the intended countries of use.

The user must obtain a license before using the product in intended country of use. Ensure respective country licensing requirements are complied with.

Limitations of use can apply in respect of operating frequency, transmitter power and/or channel spacing.

Declaration of Conformity

Hereby, R.V.R. Elettronica SpA, declares that this FM transmitter is in compliance with the essential requirements and other relevant provisions of Directive 1999/5/EC.



This page intentionally left blank

INDEX

Preliminary Instructions and Warranty Information Pag. 5

Safety Regulations Pag. 7

SECTION 1

General Description Pag. 10

Electrical Specifications (Table A) Pag. 12

Dimensional & Environmental Specifications (Table B) Pag. 14

SECTION 2

Electrical Description Pag. 15

Front Panel View Description Pag. 18

Front Panel View (Fig. 1) Pag. 20

Rear Panel View Description Pag. 21

Rear Panel View (Fig. 2) Pag. 23

Top View Description Pag. 24

Top View (Photo 1) Pag. 25

Bottom View Description Pag. 26

Bottom View (Photo 2) Pag. 27

Block Diagram (Fig. 3) Pag. 28

SECTION 3

Installation Procedure Pag. 29

Recommend Test Equipment (Table C) Pag. 33

SECTION 4

Maintenance Pag. 34

SECTION 5

Calibration Procedure of Modules Pag. 37

SECTION 5

Alignment of the Radio Link Pag. 43

APPENDIX A

Circuit Diagram, Bills of Material and Layouts		Pag. 51
Main Card		Pag. 52
V.C.O. Card		Pag. 60
C.P.U.		Pag. 65
Modmeter Card		Pag. 75
Anameter Card		Pag. 80
Power Supply		Pag. 88
2W R.F. Power Amplifier		Pag. 99
5W R.F. Power Amplifier (Vers.1)	Freq. Range 806MHz-870MHz	Pag. 104
5W R.F. Power Amplifier (Vers.2)	Freq. Range 806MHz-870MHz	Pag. 108
10W R.F. Power Amplifier (Vers.1)	Freq. Range 200MHz-240MHz	Pag. 112
10W R.F. Power Amplifier (Vers.2)	Freq. Range 310MHz-340MHz Freq. Range 380MHz-400MHz	Pag. 116
10W R.F. Power Amplifier (Vers.3)	Freq. Range 470MHz-512MHz	Pag. 120
Con-PA Card		Pag. 124
Inverter Card		Pag. 128
Audio Input Card		Pag. 132
Stereo Coder Card		Pag. 136

PRELIMINARY INSTRUCTIONS AND WARRANTY INFORMATION

Please observe safety precautions when handling this unit. This equipment contains dangerous currents and high voltages.

This manual is written as a general guide for those having previous knowledge and experience with this kind of equipment. It is not intended to contain a complete statement of all safety warnings which should be observed by personnel in using this or other electronic equipment.

R.V.R. doesn't assume responsibility for injury or damage resulting from improper procedures or practices by untrained/unqualified personnel in the handling of this unit.

Please observe all local codes and fire protection standards in the operations of this unit.

CAUTION: always disconnect power before opening covers or removing any part of this unit. Use appropriate grounding procedures to short out capacitors and high voltage points before servicing.

Any damage to the goods must be reported to the carrier in writing on the shipment receipt. Any discrepancy or damage discovered subsequent to delivery, shall be reported to R.V.R. within five (5) days from its receipt.

R.V.R. extends to the original end-user purchaser all original manufacturers warranties which are transferable and all claims are to be made directly to R.V.R. per indicated procedures.

All manufacturers warranties will be supported by R.V.R. to ensure precise and speedy service where possible.

R.V.R. shall not be liable for any damage of whatsoever nature, arising out of or in connection with the product or its use thereof.

R.V.R.'s warranty shall not include:

- a. Re-shipment of the unit to R.V.R. for repair purposes
- b. Any unauthorized repair/modification
- c. Incidental/consequential damages as a result of any defect
- d. Nominal non-incidentals defects
- e. Re-shipment costs or insurance of the unit or replacement units/parts

Warranty shall come into force from invoice date and for the period of the manufacturer's warranty.

To claim your rights under this warranty:

- a. Contact the dealer or distributor where you purchased the unit. Describe the problem and ask if he has an easy solution. Dealers and Distributors are supplied with all the information about problems that may occur and usually they can repair the unit quicker than what the manufacturer could do. Very often installing errors are discovered by dealers.
- b. If your dealer cannot help you, contact R.V.R. in Bologna and explain the problem. If it is decided to return the unit to the factory, R.V.R. will mail you a regular authorization with all the necessary instructions to send back the goods.
- c. When you receive the authorization, you can return the unit. Pack it carefully for the shipment, preferably using the original packing and seal the package perfectly. The customer always assumes the risks of loss (i.e., R.V.R. is never responsible for damage or loss), until the package reaches R.V.R. premises. For this reason, we suggest you to insure the goods for the whole value. Shipment must be effected C.I.F. (PREPAID) to the address specified by R.V.R.'s service manager on the authorization. **DO NOT RETURN UNITS WITHOUT OUR AUTHORIZATION AS THEY WILL BE REFUSED.** Be sure to enclose a written technical report where mention all the problems found and a copy of your original invoice establishing the starting date of the warranty.

Replacement and warranty parts may be order from the following address. Be sure to include the equipment model and serial number as well as part description and part number.

R.V.R. Elettronica S.r.l. - Broadcasting Equipment -
Via del Fonditore, 2/2c
Zona Roveri
40138 Bologna - Italy
International Phone: +39 - 51 - 6010506
FAX Number: +39 - 51 - 6011104

R.V.R. reserves the right to modify the design and specifications of the equipment in this manual without previous notice.

WARNING !

The currents and voltages in this equipment are dangerous!
Personnel must at all times observe safety regulation!

This manual is intended as a general guide for trained and qualified personnel who are aware of the dangers inherent in handling potentially hazardous electrical and electronic circuits.

It is not intended to contain a complete statement of all safety precautions which should be observed by personnel in using this or other electronic equipment.

The installation, operation, maintenance and service of this equipment involves risks both to personnel and equipment, and must be performed only by qualified personnel exercising due care.

R.V.R. ELETTRONICA s.r.l. shall not be responsible for injury or damage resulting from improper procedures or from the use of improperly trained or inexperienced personnel performing such tasks.

During installation and operation of this equipment, local building codes and fire protection standards must be observed.

WARNING !

Always disconnect power before opening covers, doors, enclosures, gates, panels or shields.
Always use grounding sticks and short out high voltage points before servicing. never make internal adjustments, perform maintenance or service when alone or when fatigued.

Do not remove, short-circuit or tamper with interlock switches on access covers, doors, enclosures, gates, panels or shields.

Keep away from live circuits, know your equipment and don't take chances.

WARNING !

In case of emergency ensure that power has been disconnected

Treatment of electrical Shock

1) If victim is not responsive follow the A-B-C's of basic life support.

PLACE VICTIM FLAT ON HIS BACK ON A HARD SURFACE

A AIRWAY

IF UNCONSCIOUS,
OPEN AIRWAY

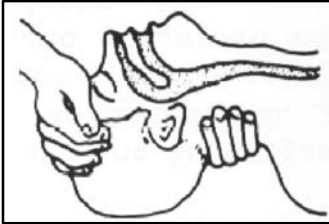

LIFT UP NECK,
PUSH FOREHEAD BACK,
CLEAR OUT MOUTH IF NECESSARY,
OBSERVE FOR BREATHING.

B BREATHING

IF NOT BREATHING,
BEGIN ARTIFICIAL
BREATHING



TILT HEAD,
PINCH NOSTRILS,
MAKE AIRTIGHT SEAL,
4 QUICK FULL BREATHS.
REMEMBER MOUTH TO MOUTH
RESUSCITATION MUST BE
COMMENCED AS SOON AS
POSSIBLE.

C CIRCULATION

CHECK CAROTID PULSE

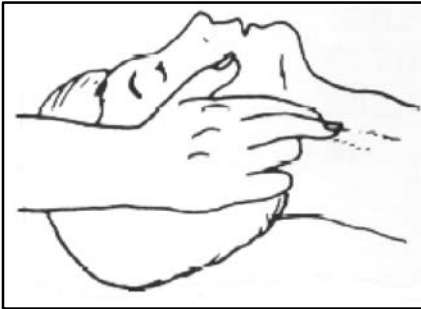

IF PULSE ABSENT,
BEGIN ARTIFICIAL
CIRCULATION

DEPRESS STERNUM 1 1/2" TO 2"

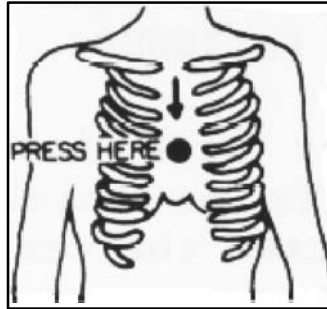

APPROX. 80 SEC. : ONE RESCUER, 15 COMPRESSIONS,
2 QUICK BREATHS.

APPROX. 60 SEC. : TWO RESCUERS, 5 COMPRESSIONS,
1 BREATH

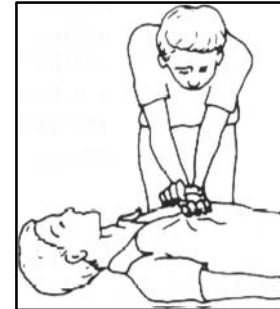

NOTE: DO NOT INTERRUPT RHYTHM OF COMPRESSIONS
WHEN SECOND PERSON IS GIVING BREATH.

Call for medical assistance as soon as possible.

- 2) If victim is responsive.
- Keep them warm.
 - Keep them as quiet as possible.
 - Loosen their clothing (a reclining position is recommended).

FIRST-AID

Personnel engaged in the installation, operation, maintenance or servicing of this equipment are urged to become familiar with first-aid theory and practices. The following information is not intended to be a complete first-aid procedure, it is brief and is only to be used as a reference. It is the duty of all personnel using the equipment to be prepared to give adequate Emergency First Aid and thereby prevent avoidable loss of life.

Treatment of electrical Burns

- 1) Extensive burned and broken skin.
 - a. Cover area with clean sheet or cloth.
(Cleanest available cloth article).
 - b. Do not break blisters, remove tissue, remove adhered particles of clothing, or apply any salve or ointment.
 - c. Treat victim for shock as required.
 - d. Arrange transportation to a hospital as quickly as possible
 - e. If arms or legs are affected keep them elevated.

NOTE

If medical help will not be available within an hour and the victim is conscious and not vomiting, give him a weak solution of salt and soda: 1 level teaspoonful of salt and 1/2 level teaspoonful of baking soda to each quart of water (neither hot or cold). Allow victim to sip slowly about 4 ounces (half a glass) over a period of 15 minutes. Discontinue fluid if vomiting occurs (Do not give alcohol).

- 2) Less severe burns - (1st & 2nd degree)
 - a. Apply cool (not ice cold) compresses using the cleanest available cloth article.
 - b. Do not break blisters, remove tissue, remove adhered particles of clothing, or apply salve or ointment.
 - c. Apply clean dry dressing if necessary.
 - d. Treat victim for shock as required.
 - e. Arrange transportation to a hospital as quickly as possible.
 - f. If arms or legs are affected keep them elevated.

CHAPTER 1

GENERAL DESCRIPTION

1.1 MECHANICAL DESCRIPTION

The PTRL-NV/S3 is housed in a 3U, 19" rack-mounting chassis comprising a number of interconnected modules mounted internally on the base of the unit.

This allows easy removal and replacement of each module.

The power output control, audio output level control and meters for various operating parameters are situated on the front panel.

Mains power and R.F. output connectors are mounted on the rear panel.

1.2 ELECTRICAL DESCRIPTION

The PTRL-NV/S3 is a high quality, broadband, FM Stereo transmitter with a standard output power of 2W.

The transmitter is microprocessor-controlled and synthesized with steps of 10 KHz in the 200-1100 MHz band.

The operating frequency is governed by a thermally compensated reference oscillator working within a phase locked loop (PLL).

The transmitter incorporates a stereo coder with an excellent stereo separation and a low level of harmonic distortion, and provides the input for two SCA (RDS) signals.

A front switch allows operations in "STEREO" or "MONO/MPX"; in the latter, the coder is excluded and the "RIGHT" input is used as a "MONO" input, the "LEFT" input as a "WIDEBAND COMPOSITE INPUT". The low intermodulation and distortion values (typ. 0.03%) and the high signal to noise ratio (typ. 80 dB) are the main features of this coder.

The transmitter will attain frequency lock within a maximum of 30 seconds. The operating bands is 15-25 MHz depending upon the application. The final stage is fully protected against any level of VSWR. Furthermore, a 15 KHz low-pass filter is provided which may be inserted in the mono or MPX input.

1.3 METERS AND INDICATORS

The transmitter's operating parameters can be measured with the analog multimeter (17 Fig.1) and the led bar-graph display (3 Fig.1) situated on the front panel. The measurement being made by the analog multimeter is indicated by a led indicator (14 Fig.1) and selectable via the corresponding control (13 Fig.1).

Peak deviation can be measured with the bar-graph display (3 Fig.1) with a resolution of 5%. The five-figure display (12 Fig.1), mounted centrally, indicates the operating frequency selected by the UP (11 Fig.1) and DOWN (8 Fig.1) controls and saveable with the ENTER (9 Fig.1) control. Two alarm conditions leds provide indication of VCO unlocked (16 Fig.1) and excess standing waves on the output (15 Fig.1).

1.4 REMOTE CONTROL (OPTIONAL)

In this equipment an optional serial port (9 pin D-type) is available allowing remote control of operating frequency and output power.

1.5 SPECIFICATIONS

Please refer to Table A for the electrical specifications and Table B for the mechanical specifications.

TABLE A

ELECTRICAL SPECIFICATIONS

A.C. Power	117 or 230V \pm 10% 50-60 Hz, single phase 49 W
Cooling	Forced ventilation
Operating frequency	from 200 to 1100 MHz in 15-25 MHz bands (by request)
Output power	from 0.2 W to 2 W (up to 5 W or 10 W by request)
Output impedance	50 Ohm
R.F. output connector	N-type
Harmonic suppression	better than 55dB complying with FCC and CCIR regs
Pre-emphasis	75 microseconds for FCC 50 microseconds for CCIR
Audio input impedance, mono	600 Ohms unbalanced
Audio input level	0 /-10 dB nominal for \pm 75 KHz at 400Hz, adjustable
Audio frequency response	\pm 0.5 dB from 30 Hz to 15 KHz
FM S/N ratio	better than -70 dB mono, -65 dB stereo, \pm 75 KHz deviation at 400 Hz measured in the 30 Hz to 20 KHz band by RMS detector
Total harmonic distortion,	< 0.05% mono, 0.10% stereo
MPX input impedance	10 KOhm, 1 unbalanced BNC
Total harmonic distortion, MPX	< 0.2%

S/N ratio, FM stereo	better than -70 dB, \pm 75KHz deviation at 400 Hz, right and left channels decoded and de-emphasized
MPX amplitude response	\pm 0.5 dB from 30 Hz to 100 KHz
Stereo separation	greater than 45 dB
<u>Optional inputs for 0 dBm audio level:</u>	
SCA input impedance	10 KOhm, 3 unbalanced BNCs
SCA input level	0 dBm nominal for \pm 7.5 KHz

TABLE B
MECHANICAL SPECIFICATIONS

Chassis dimensions	132.5 mm (5.2") H 345 mm (13.7") D 483 mm (19") W
Panel dimensions	483 mm (19") W 132.5 mm (5.2") H
Ambient operating temp.	from -10°C to +50°C
Humidity	90% maximum, non-condensing
Weight	26.4 Lbs (12 Kg)

CHAPTER 2

ELECTRICAL DESCRIPTION

2.1 INTRODUCTION

This section describes, in detail, the operating theory of the PTRLNV/S3. To aid understanding, the unit has been subdivided into blocks, each of which is fully described below. A block diagram is shown in Fig.3.

2.2 POWER SUPPLY

This sub-assembly comprises 2 board mounted on heat-skins, in turn mounted at right-angles to each other on the chassis base (Photo 1-2). The power supply generates the stabilized voltages required by the various modules comprising the PTRLNV/S3. After having undergone filtering for mains-borne interference, the supply is transformed to lower voltages, rectified, smoothed and stabilised for the following outputs: +5V, +12V, +15V, -15V and 2-18 V variable. The +5V output supplies the CPU card, the +15V outputs supply the Main card, the CPU card, the coder mixer, the Modmeter card and the Anameter cards 1 and 2; the +12V output supplies the final power stage of the transmitter. The voltage applied to the final stage is varied by the PWR ADJ control. An automatic output power limiting system intervenes in the case of excess S.W.R. on the R.F. output. All supply voltages and the current drawn by the final stage may be monitored by the analog multimeter.

2.3 AUDIO INPUT CARD

This card is situated on the rear panel of the transmitter (see Photo 1-2).

The card filters all audio signal inputs to the unit incoming from the outside world, removing RF interference, before supplying them to the encoder mixer.

The main operating parameters of the transmitter are available for remote monitoring via a 9-pin D-type serial connector.

2.4 CODER MIXER

This board is placed underneath the internal chassis (see photo 2). The card can function either as a stereo encoder or as a simple mixer for the various audio inputs.

The function may be selected by a control situated on the front panel. In stereo encoder mode, the 19 KHz pilot tone is derived from a quartz crystal reference oscillator. So too is the sampling frequency which allows the L and R signals to be separated from the multiplexed signal, plus the suppression of the 38 KHz frequency.

The level of the left and right signals is set by the corresponding selector situated on the front panel. The signals are then filtered at 15 KHz and pre-emphasized (50 uS CCIR, 75 uS FCC) before being sent to the multiplex circuit.

The audio signals from the two SCA inputs are mixed in to provide the output.

In mixer mode (Mono MPX) the stereo encoder is bypassed, the right input accepts a mono signal and the left input accepts a multiplex signal upto 100 KHz. The SCA inputs remain unchanged.

Three rectifiers allow the peak levels of the two inputs "LEFT/MPX" and "RIGHT/MONO" to be displayed on the analog meter, and provide the audio detector circuit with the deviation level.

2.5 MAIN CARD

The Main card is situated on the lower left side of the unit (Photo 1). This card contains a voltage-controlled oscillator (VCO), housed in a metal box, which generates the operating frequency of the transmitter which has been programmed. The audio signal, coming from the two MONO and STEREO connectors on the front panel, is amplified and injected into the VCO to produce a class F3E modulation. On the PLL circuit the VCO operating frequency is divided down and compared to a reference frequency, generated by a 4 MHz quartz crystal which is thermally-compensated by a PTC. The error voltage is filtered and fed-back to guarantee the stability of the VCO frequency. An indicator on the front panel lights when the circuit is not locked.

2.4 R.F. POWER AMPLIFIER

The power stage is mounted on a heatsink to dissapate generatde heat, and totally enclosed in a metal screening box (Photo 1-2). This sub-assembly is mounted to the base of the chassis in a contral position. The R.F. signal coming from the VCO, at power level of about 10mW, passes through the driver stage (BFR96) and is amplified by the final stage (BFQ34 and BFQ68) upto a level of 2 W (versions are available with 5 W and 10 W power outputs). The signal then passes through a low-pass filter to remove any harmonic components. A directional coupler allows both direct and reflected power to be measured and fed-back to the power supply. The direct power reading is also connected to the multimeter.

2.6 CPU

The CPU is housed in a metal box and mounted centrally on the rear of the front panel (Photo 1-2). This circuit converts the number corresponding to the selected operating frequency into binary code which is written to the programmable dividers of the PLL. This allows the VCO to lock to the desired operating frequency. Several of the transmitter's parameters may be remotely controlled via an optional 9 pin D-type serial port.

In the absence of mains power, a non-volatile memory maintains indefinitely, the last frequency that was programmed.

2.7 MODMETER

This card is mounted on the left side of the front panel (Photo 1). This circuit allows the deviation of the VCO frequency to be displayed by rectifying the signal supplied to the Main card. The card has two connectors; one for the mono signal and the other for the stereo signal. A switch allows the gain of the measuring circuit to be set to 10% or 100% for a more precise reading of low-level deviation (eg. SCA, RDS, MPX pilot tones). Another switch sets the display mode to bar-graph or peak mode. The display comprises 14 green leds and 6 red leds. In the 100% display mode, each led represents 5 KHz of deviation with the first red led representing 75 KHz and FDS at 100 KHz. In the 10% mode, each led represents 0.5 KHz of deviation.

2.8 ANAMETER

This circuit comprises two cards and a meter mounted on the right hand side of the front panel (Photo 1-2). This sub-assembly displays the values of various operating parameters of the transmitter: internal voltages and currents, direct power and external 24V. The parameters are selected by a lever switch (13 Fig.1) and the selection is indicated by the legend of the green led (14 Fig.1).

The readings are taken using the corresponding scale:

MEASUREMENT	SCALE	FDS
Audio Level	dB	+3 dB
Internal voltages	V	30 V
Internal currents	A	6 A
Direct power	W	10 W (5/10W version)
Reflected power	W	2.5 W (2W version)

This circuit also features a red UNLOCK led (16 Fig.1) and a red SWR led (15 Fig.1), controlled by the power supply. In addition there are: a red power led (19 Fig.1), a power output PWR trimmer (10 Fig.1) and the mains supply switch (18 Fig.1).

FRONT PANEL DESCRIPTION

(Fig. 1)

1	BAR/DOT	Selector of operation mode (BAR/DOT) for deviation meter
2	STEREO/MONO-MPX	Selector for "STEREO" or "MONO-MPX" operation
3	MODULATION	Modulation meter by "Led Diode Bar"
4	10%-100%	Expansion of modulation meter scale Pos. 10% - Full scale shows 10% Pos. 100% -Full scale shows 100%
5	MODE SELECTOR	Pushed button: "STEREO MODE OPERATION" Pushed button: "MONO MODE OPERATION"
6	L/MPX/R/MONO IN. LEVEL	Continuously adjustable input level from -12 to +9 dBm
7	INPUT LEVEL	Input attenuator in five steps from -9 to +6 dBm
8	DOWN	Control frequency display. A momentary pushes causes the digit to go down 10KHz a time
9	ENTER	Enters the frequency on the display into microprocessor and memory. Once entered, the frequency is stored until a new frequency is entered on the front panel even if the power is turned off for several days
10	PWR ADJ	A ten turn control which controls the power output of the exciter. Once set the power remains at that level due to AGC action.
11	UP	Controls the display frequency in the same way as the "DOWN" button, except that the frequency goes up in 10 KHz steps
12	FREQUENCY DISPLAY	Frequency indicator
13	METER SWITCH	Pushing the switch each time will light on led at a time in upward direction
14	LEDS	Light indicator indicated which parameter of the exciter is being displayed on the analog meter
15	SWR ALARM	If this indicator lights, it means that the exciter shut down to a high VSWR condition on the output

16	UNLOCK	This indicator will light when the VCO is not locked to the reference frequency. Power output will also decrease to zero in this condition
17	METER	Analog meter used to monitor the parameters of the exciter such as: +15V +12V +5V Forward Power EXT 24V VPA IPA AFC
18	POWER	ON/OFF Power Switch
19	ON	A.C. Power ON Indicator

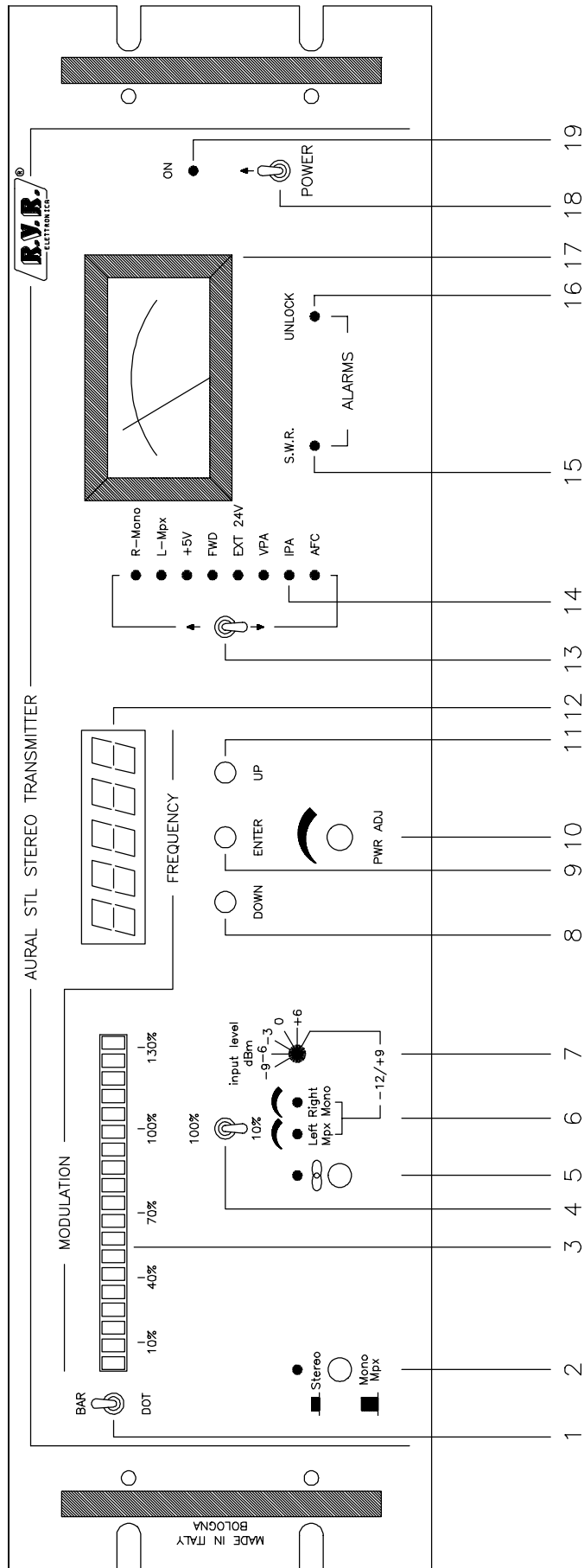

FRONT PANEL (FIG. 1)

REAR PANEL VIEW (Fig.2)

1	PLUG	A.C. Power Plug
2	FUSE BLOCK	Fuse Block & Voltage Setting. Use a small screwdriver to change fuse or voltage setting. Turn block and place desired operating voltage next to arrow
3	EXT 24V (+)	Positive terminal for EXT 24 (Optional)
4	REMOTE CONTROL (Optional)	DB9 communication line to control or receive status of the transmitter. Baud rate is 1200 Baud. On request, it may be changed to 300, 600 or 2400 baud. A program is available on 5 1/4" or 3 1/2" disk for IBM or compatible. Plug is a standard DB9 female Pin 1 Not Connected Pin 2 TXD Pin 3 RXD Pin 4 DSR * Pin 5 GND Pin 6 DTR * Pin 7 CTS \$ Pin 8 RTS \$ Pin 9 Not Connected * DSR and DTR are connected together \$ CTS and RTS are connected together
5	INTERLOCK	BNC connector which permits to put the exciter in stand-by
6	EXT 24V (-)	Negative terminal for EXT 24V (Optional)
7	FAN	Cooling fan
8	R.F. OUTPUT	50 Ohm, "N" Connector
9	R.F. TEST -30dB	R.F. Test point connector -30dB (only in 900 MHz version)
10	RIGHT (MONO)	FCC Version BNC connector isolated, CCIR Version "Cannon XLR" connector balanced input
11	LEFT (MPX)	FCC Version BNC connector isolated, CCIR Version "Cannon XLR" connector balanced input
12	SCA 1	BNC connector, unbalanced SCA 1 input
13	SCA 2	BNC connector, unbalanced SCA 2 input or internally switchable pilot output for RDS Coder

14	TELEMETRY TERMINALS	10 pin terminal board for telemetry
		1-2 AUDIO GND
		3-10 GND
		4 FWD POWER
		5 REF POWER
		6 VPA VOLTAGE DC
		7 IPA CURRENT
		8 SWR ALARM
		9 UNLOCK ALARM

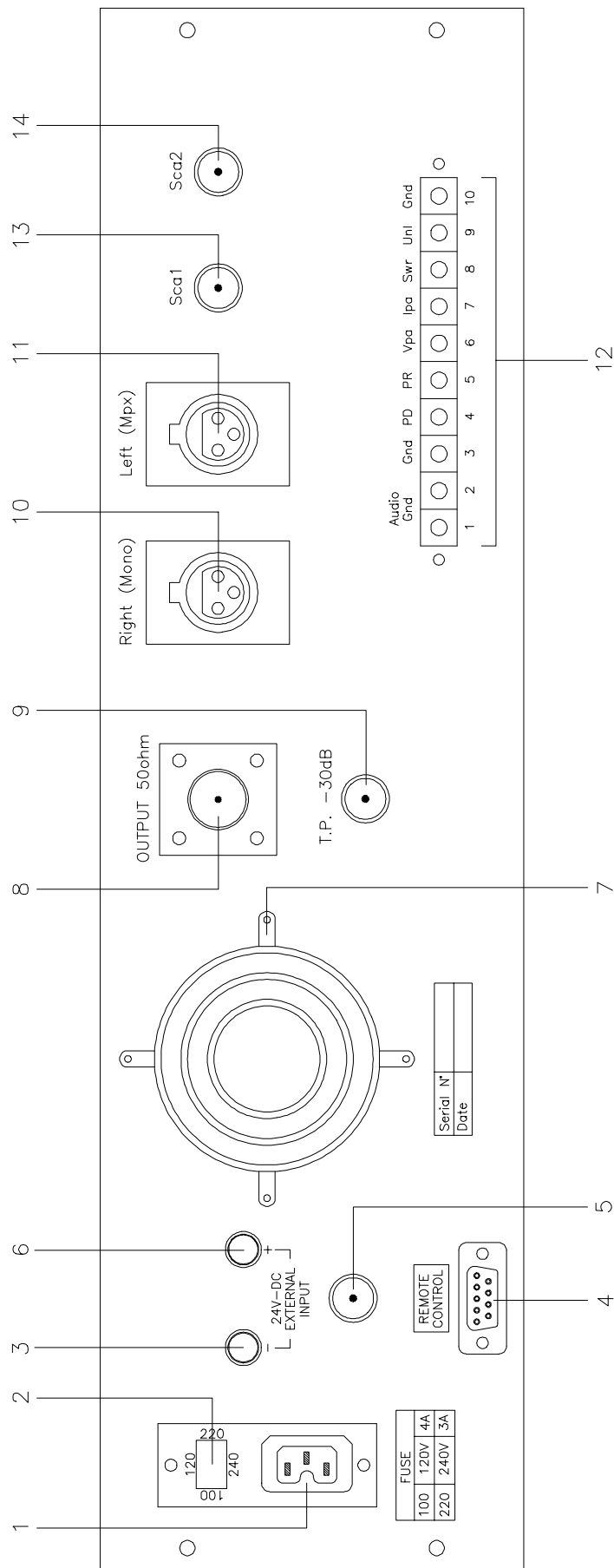

REAR PANEL (FIG.2)

TOP VIEW DESCRIPTION (PHOTO 1)

- 1 Power Supply
- 2 R.F. Power Amplifier
- 3 Transformer
- 4 Anameter Card
- 5 Audio Input Card
- 6 Main Card
- 7 C.P.U.
- 8 Modmeter Card

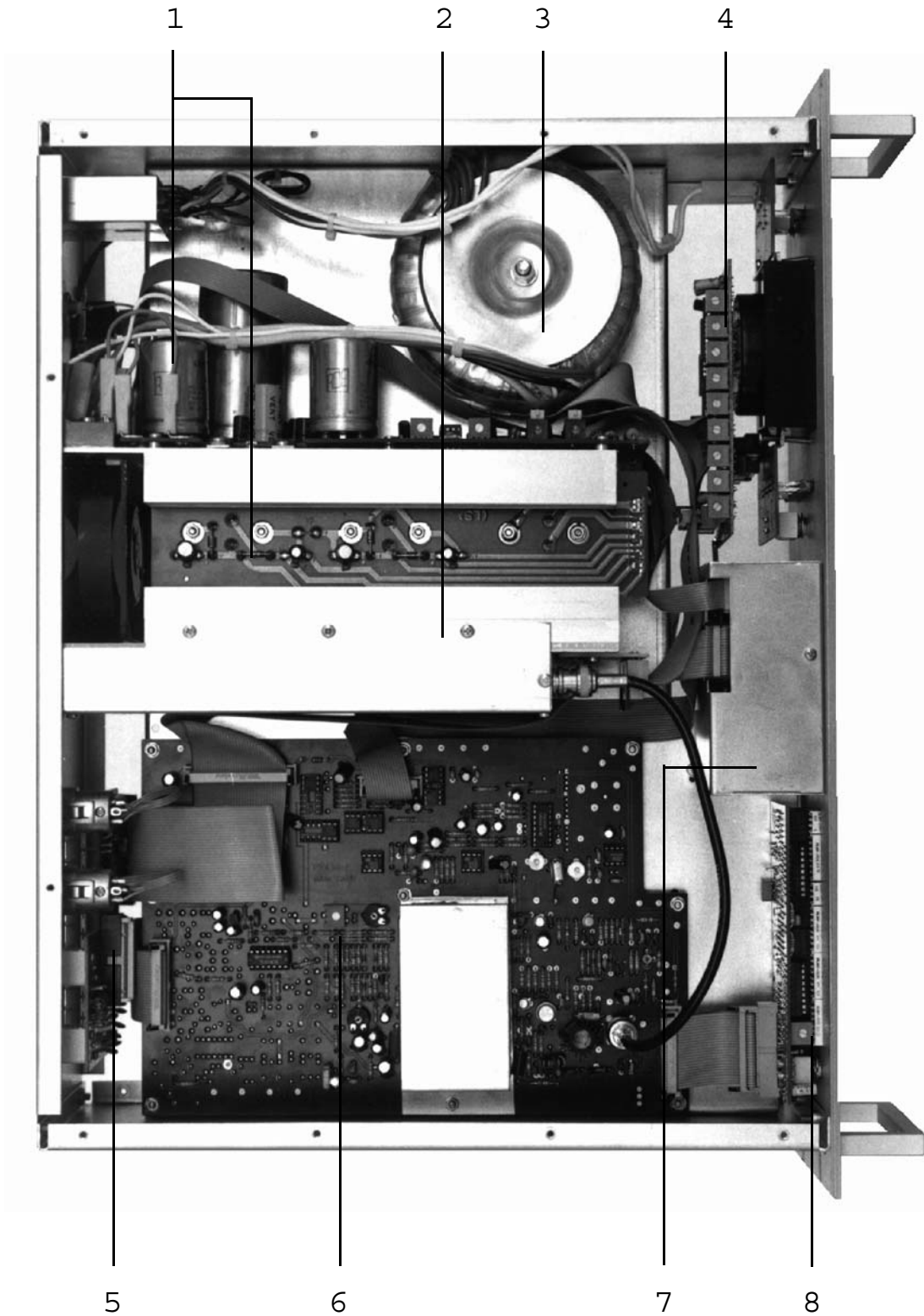

TOP VIEW (PHOTO 1)

BOTTOM VIEW DESCRIPTION (PHOTO 2)

- 1 Audio Input Card
- 2 Stereo Coder Card
- 3 Power Supply
- 4 R.F. Power Amplifier
- 5 C.P.U.
- 6 Anameter Card

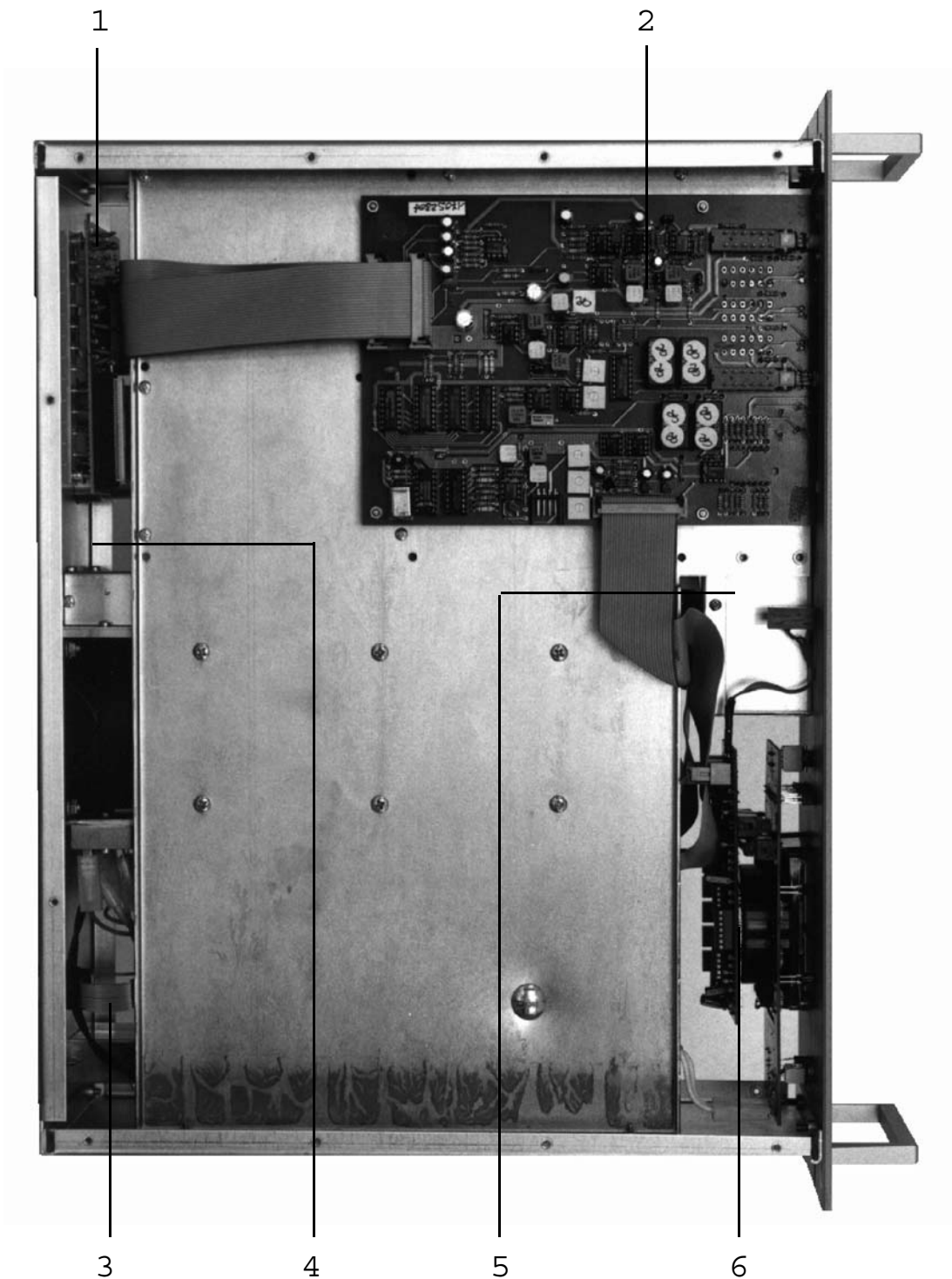

BOTTOM VIEW (PHOTO 2)

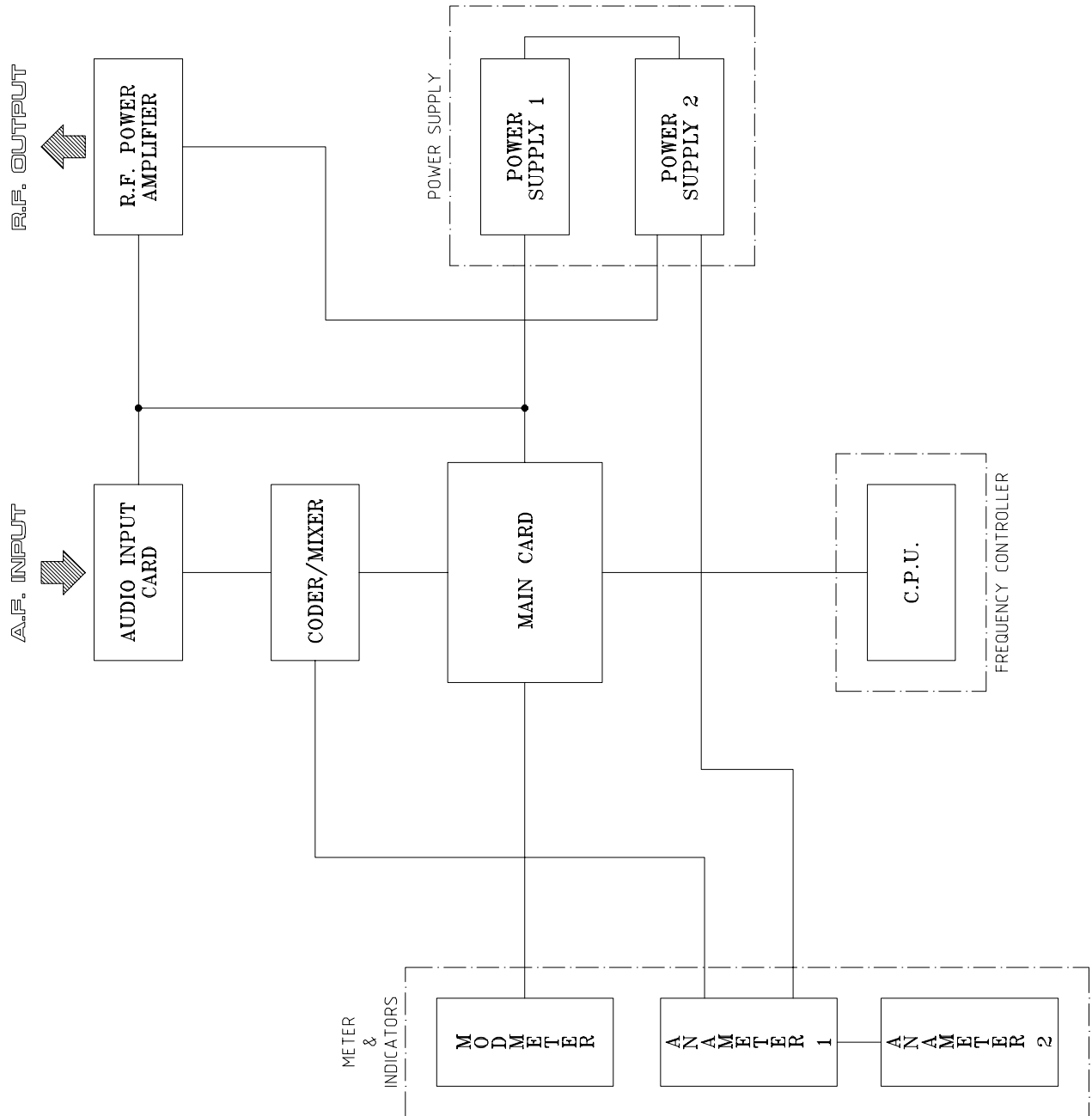

BLOCK DIAGRAM (FIG. 3)

CHAPTER 3

INSTALLATION

3.1 INTRODUCTION

This chapter contains the information required to install the PTRLNV/S3 and carry out preliminary checks.

3.2 UNPACKING

Remove the unit from its packing and, before anything else, ensure that the unit has not suffered any damage during transit and that all front and rear panel controls are operational.

3.3 INSTALLATION

- 1) This transmitter is able to operate from 4 different supply voltages: 100, 120, 220 or 240 Vac, at 50-60 Hz. First of all select the correct supply voltage using the selector situated on the rear panel; use a screwdriver to raise the cover (2 Fig.2) on which are written the various voltages, rotate it until the arrow points to the correct voltage and re-insert it. Check that a fuse is fitted to the cover and that its value corresponds to the following:

<u>220-240 Vac</u>	<u>2 A</u>
<u>100-120 Vac</u>	<u>3.1 A</u>

- 2) Now ensure that the PWR ADJ control (10 Fig.1) is rotated fully counter-clockwise for minimum power using a small screwdriver. Since the control is a ten-turn potentiometer, it may be necessary to double-check the adjustment. Units are normally supplied with this control set to maximum.
- 3) Connect a dummy load with a continuous power rating of at least 10W at the unit's required operating frequency, to the R.F. output connector situated on the rear panel. A bypass Wattmeter should be connected in series with this load in order to verify the reading of the unit's own internal wattmeter (SETUP 1 / Fig.4).

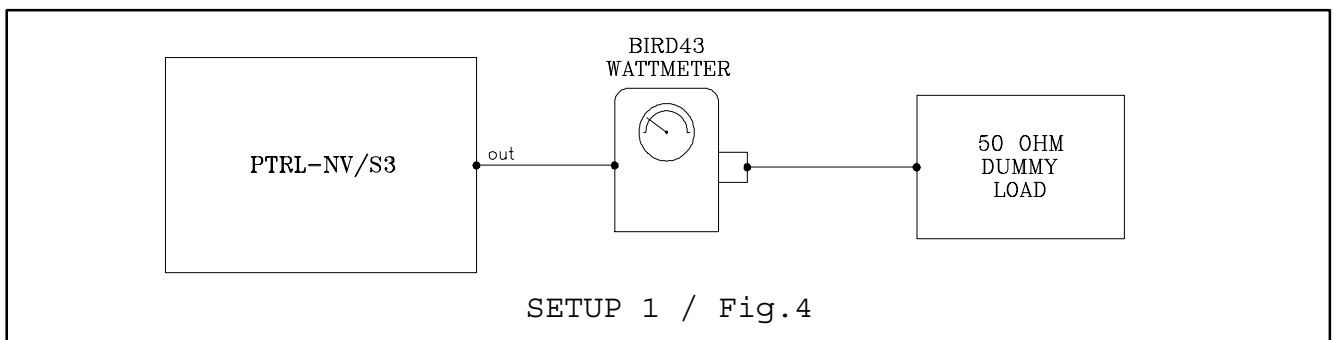

- 4) Connect a switch, via a cable, to the INTERLOCK connector (5 Fig.2) on the rear panel so that the switch is able to short the central conductor to this screen and leave the switch in the short-circuit position.
- 5) Switch the power switch (18 Fig.1) to the OFF position.
- 6) Connect power to the unit via the VDE socket (1 Fig.2).

N.B. It is essential that the unit be properly earthed to ensure both the safety of the operator as well as the correct functioning of the equipment.

- 7) Switch the power switch to the ON position and check that the green POWER ON led (19 Fig.1), the red UNLOCK led (16 Fig.1) and the led corresponding to the parameter selection PWR FWD (14 Fig.1), are all lit. After a few seconds the central display (12 Fig.1) will come on and display a number (eg. 760.00) corresponding to the last operating frequency to have been programmed.
The green UNLOCK led should switch on within 30 seconds indicating that the oscillator has locked to the operating frequency displayed. The display has five digits, 3 before the decimal point representing (from left to right) hundreds of MHz, tens of MHz and MHz; and 2 after the decimal point representing hundreds and tens of KHz. To change this number, use the UP (11 Fig.1) and DOWN (8 Fig.1) buttons to respectively increase it and decrease it. Once the desired frequency has been found, press ENTER (9 Fig.1) to confirm and save it.
As soon as the ENTER button has been pressed, the UNLOCK led will come on (providing that the new frequency is different from the old), indicating that the VCO is re-tuning to the new frequency. If the ENTER button is not pushed, the display will flash the new value four times and then reset to the previous value.

NOTE: The transmitter will continue to function normally at the same frequency, throughout the procedure described above, until the ENTER button is pressed.

Note that a momentary press of the UP and DOWN buttons will increment or decrement the rightmost digit by 1 (corresponding to a frequency change of 10 KHz).

A longer press of either button will cause the display to increment or decrement continuously until the button is released.

Furthermore, when the limit of the operating frequency band is reached, the displayed frequency will jump to the other limit and carry on changing in the direction corresponding to the button being pushed.

NOTE: The frequency band is pre-defined by the user and rarely exceeds 25 MHz.

Exemple: Band 840-860 MHz:

UP button pressed:	859.99	860.00	840.00	840.01
DOWN button pressed:	840.01	840.00	860.00	859.99

After the PLL has been locked for about 90 seconds, the display turns off automatically.

To switch it on, press the ENTER button.

- 8) Having verified that the transmitter has locked into the desired operating frequency by checking that the UNLOCK led is off, set the switch so as to remove the short-circuit from between the two conductors of the REMOTE cable.
The R.F. power output is now enable.
Adjust the power control PWR ADJ until maximum power is reached. This will be about 2W (5 or 10W for special versions).
To make this measurement, ensure that the PWR ADJ led is on by setting the meter switch (13 Fig.1) to the corresponding position and then take the reading from the 10W FDS scale on the meter.
- 9) Using a small screwdriver or trimmer tool, rotate the PWR ADJ control counter-clockwise, checking that the output power falls gradually to a minimum of about 0,2W (1W for 5W version and 2W for the 10W version).
Check the power reading against that of the bypass wattmeter ($\pm 10\%$).
- 10) Re-adjust the output power to 2W (or maximum power in the case of the 5 or 10W versions) and select a new operating frequency at least 5MHz away from the current value.
On pressing ENTER, the UNLOCK led should light and the output power fall to zero.
The power level should return to its previous value only when the UNLOCK led goes out (oscillator locked to new frequency).
- 11) SWR protection check.
Disconnect the load from the R.F. output and check that the SWR led comes on. The direct power reading on the unit's multimeter should be about 50% of maximum (-3dB).
Check that the SWR led goes out and the power level returns to its previous value when the load is reconnected.
- 12) Now short-circuit the REMOTE input and the power level should immediately fall to zero.
Removing the short should result in the power output returning gradually to its previous level.
- 13) Deviation meter check.
Set the modulation bar-graph display gain (4 Fig.1) to 100%.
Connect a low-distortion audio frequency generator to the MONO input (10 Fig.2) or STEREO inputs (10-11 Fig.2).
Inject a 400Hz tone at a level of -10 dBm for the european version or 0dBm (775mV RSM = 2.2V peak to peak) for the american version.

Check that the bar-graph display (3 Fig.1) lights upto the first red led, indicating 100% deviation.

With the DOT/BAR switch (1 Fig.1) in the BAR position, all the green leds and first red led will be on; in the DOT position only the first red led will be on.

Now disconnect the audio generator and ensure that all the bar-graph leds go out (3 Fig.1).

Set the control (4 Fig.1) to 10% and inject a 400Hz tone of -30dBm (-20 dBm for the american version) and repeat the proceeding operation. The procedure should be followed first for the MONO input and then for the STEREO inputss.

TABLE C

RECOMMENDED TEST EQUIPMENT

INSTRUMENT	MODEL	SPECIFICATION
Non-Inductive Dummy Load	Bird	50 Ohm P>10W
Spectrum Analyzer	Advantest Mod. R4131D	10KHZ-3.5GHz
F.M. Modulation meter	R/S Mod. F.A.M.	
Digital multimeter	Mod. Metrix	
Bypass Wattmeter	Bird Mod. 43	50 Ohm
Stereo Decoder	A.E.V. Mod. SMD	Stereo separation >60 dB 30Hz to 15KHz
Low distortion A.F. generator	Krohn-Hite	THD < 0.001%
Oscilloscope	Tektronix	DC-20MHz
R.F. generator	R/S Mod. SMG	100KHz 1GHz
Audio Analyzer	Panasonic Mod. 2247A	
30dB Attenuator	H.P. Mod. 8498A	Max Avg Pwr 30W
Variable Attenuator	H.P. Mod. 8496B	Attenuator 110dB Max RF PWR 1W CW
Variable Attenuator	H.P. Mod. 8494B	Attenuator 11dB Max RF PWR 1W CW

CHAPTER 4

MAINTENANCE

4.1 SAFETY REQUIREMENTS

WARNING WARNING WARNING WARNING WARNING WARNING WARNING

When the transmitter is operational, removing the top panel will expose lethal voltages on the line voltage selector.

Ensure that the unit is disconnected from all sources of power before carrying out any inspection or maintenance work.

MAINTENANCE LEVEL 1

4.2 ROUTINE MAINTENANCE

The only routine maintenance required by the transmitter is the periodic replacement of the cooling fan and the removal of accumulated dust.

The period between such action will depend on ambient operating conditions such as temperature, air-borne dust levels and humidity.

It is advisable to check the unit every 6 months and to replace noisy or worn fans.

Fans should be replaced as a metter of course after no more than 18 months of operation.

MAINTENANCE LEVEL 2

CARD REPLACEMENT

NOTE: TO FIT A CARD, FOLLOW THE REMOVAL PROCEDURE IN REVERSE.

4.3 MAIN CARD REPLACEMENT

- 1) Open the top cover of the unit.
- 2) Disconnect connectors CN1, CN2, CN3, CN4, CN5, CN6 and CN7.
- 3) Undo the nuts holding the card in place.
- 4) Remove the Main card with great care.

4.4 MODMETER CARD REPLACEMENT

- 1) Open the top cover of the unit.

- 2) Disconnect connector CN1 that connects the Modmeter card to the Main card.
- 3) Undo the front panel fixing screws.
- 4) Undo the Modmeter switch nuts, situated on the front panel.
- 5) Undo the MONO and STEREO connector fixing nuts on the front panel.
- 6) Slide the card out with great care.

4.5 CPU REPLACEMENT

- 1) Open the top cover of the unit.
- 2) Undo the front panel fixing screws.
- 3) Undo the nuts fixing the switches to the front panel.
- 4) Disconnect connectors CN1 and CN2 that connect the CPU to the Main card and to the rear panel RS232 connector, respectively.
- 5) Undo the screws fixing the metal container protecting the CPU, and remove it.
- 6) Remove the card with great care.

4.6 ANAMETER CARD REPLACEMENT

- 1) Open the top cover of the unit.
- 2) Undo the front panel fixing screws and the Switch Selector fixing nut.
- 3) Disconnect connector CN1 connecting the Anameter card to the power supply and connector CN1 connecting the Modmeter card to the Main card.
- 4) Disconnect the faston connectors connecting the power cables and the jumpers that connect the card to the Power Adjust connector.
- 5) Unscrew the nuts holding the card to the meter.
- 6) Remove the card with great care.

4.7 POWER AMPLIFIER REPLACEMENT

- 1) Open the top cover of the unit.

- 2) Disconnect CN1 connector of the R.F. Power Amplifier and CN1 connector of the CON-PA Card.
- 3) Unscrew the screws fixing the R.F. Power Amplifier to the base of the unit.
- 4) Remove the R.F. Power Amplifier in an upwards direction.

4.8 POWER SUPPLY REPLACEMENT

- 1) Open the top cover of the unit.
- 2) Disconnect connector CN3 and CN4.
- 3) Unscrew the screws fixing the Power Supply to the base of the unit.
- 4) Take careful note of the position of each cable with reference to its color.
- 5) Disconnect the connector CN2, on the main card, the CN7 connector and the faston connectors connecting the transformer to the bridge rectifier.
- 6) Remove the Power Supply with great care.

4.9 STEREO CODER REPLACEMENT

- 1) Open the top and the bottom covers of the unit.
- 2) Disconnect J1, J2, J3, J4 connectors.
- 3) Unscrew the 4 bolts on the board.
- 4) Unscrew the input level knob.
- 5) Extract the board paying attention to disengage the switches and the potentiometer from the main panel.

CHAPTER 5

CALIBRATION OF MODULES

5.1 CALIBRATION OF THE R.F. POWER AMPLIFIER

After replacement of the amplifier, the following procedure should be followed SETUP 1 (Fig.4):

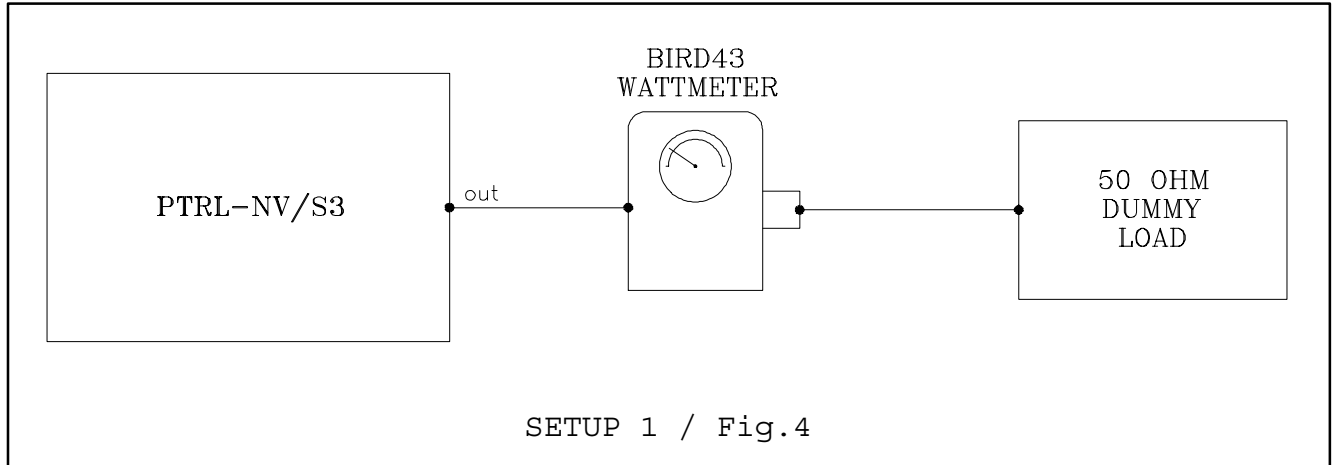

- 1) Connect a bypass wattmeter between the R.F. output and 50 Ohm dummy load.
- 2) Switch on the transmitter and wait for the PLL to lock and the power output to be enabled.
- 3) Turn the PWR ADJ trimmer (10 Fig.1) clockwise until maximum output power is obtained.
- 4) Use the external wattmeter to adjust the trimmer for a power output of 2 W (5 or 10 W for other versions).
- 5) Set the meter selector (13 Fig.1) to FWD and adjust R21 on the Anameter card for a reading of 2 W on the transmitter's own meter (17 Fig.1).
- 6) Disconnect the dummy load from the exciter output and check that the power reduces and that the SWR led (15 Fig.1) switches on. Adjust R8 on the power supply card for a reading of 50% of maximum direct power on the internal power meter.
- 7) Re-connect the dummy load and verify that the output power returns to 2 W.

5.2 CALIBRATION OF THE POWER SUPPLY

The only adjustment required after replacement of the power supply are those detailed in 5.1 (Calibration of the R.F. Power Amplifier). It is sufficient to follow steps 1 to 7 of this procedure after the power

supply has been replaced.

5.3 CALIBRATION OF THE MODMETER CARD

For this procedure please refer to SETUP 2 (Fig. 5).

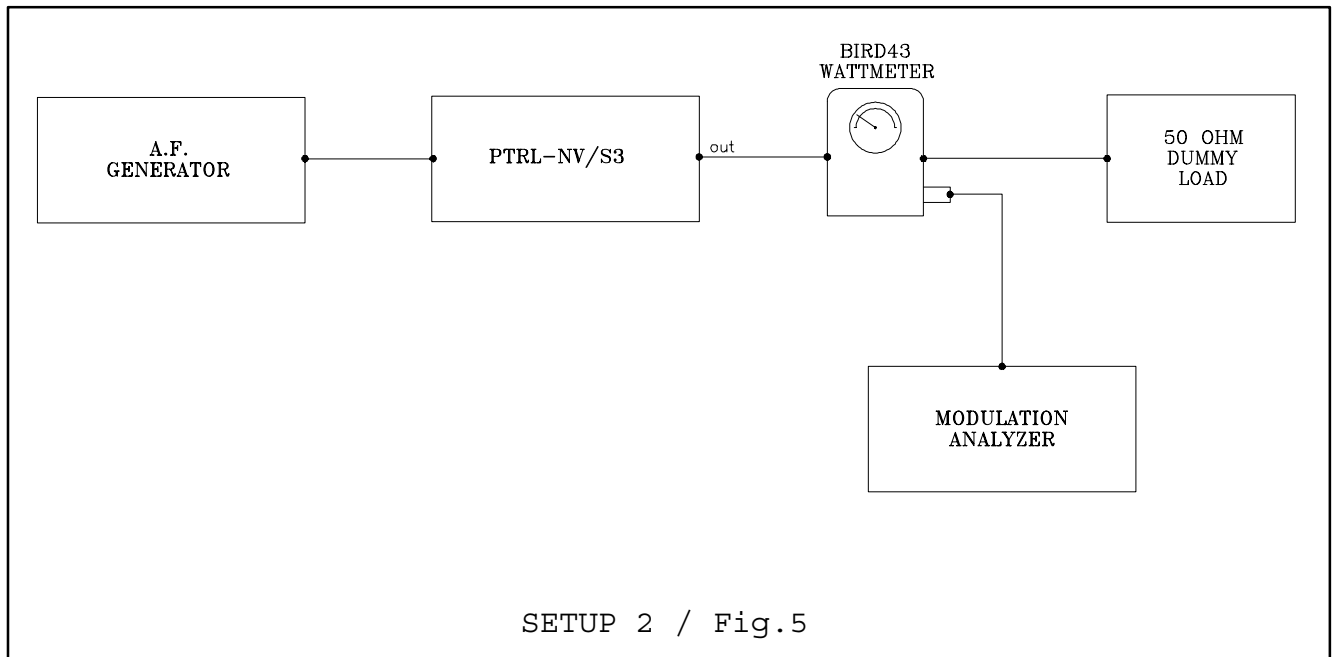

- 1) Connect a 50 Ohm dummy load to the R.F. output of the exciter.
- 2) Connect an audio frequency generator to the MONO or STEREO inputs set at a frequency of 400 Hz and an amplitude (at the connector) of -10 dBm (0 dBm for the american version).
- 3) Connect the R.F. input of the FM modulation meter to the output of the wattmeter connected to the output of the PTRL-NV/S3.
- 4) Set the switch (5 Fig.1) to 100% and adjust the AF ADJ controls (6 Fig.1) in a clockwise direction for maximum power.
- 5) Adjust trimmer R30 on the Modmeter card until the 1st red led comes on (corresponding to the 100% level).
- 6) Set the switch (4 Fig.1) to 10%.
- 7) Inject a 400 Hz signal into the input connector at a level of -30 dBm for european versions or -20dBm for american versions.
- 8) Adjust trimmer R4 on the Modmeter card until the 1st red led comes on (corresponding to a level of 10%).

5.4 CALIBRATION OF THE MAIN CARD

Having fitted the Main card and made all necessary connections, carry out the following procedure (see SETUP 2 / Fig.5):

- 1) Connect an audio frequency generator to the MONO or STEREO inputs.
- 2) Connect a 50 Ohm dummy load with a power rating of at least 10W to the R.F. output.
- 3) Connect the R.F. input of the FM modulation meter to the output of the wattmeter connected to the output of the PTRL-NV/S3.
- 4) Remove jumper J4 from the Main card.
- 5) Inject a 400 Hz signal at a level of -10 dBm ($0.775 V_{RMS}$ or $2.2 V_{PP}$ peak to peak for american versions) into the MONO input (trimmer R42 at maximum).
- 6) Set the STEREO/MONO-MPX selector (2 Fig.1) to MONO.
- 7) For american versions, inject the Mono signal at 0 dBm into the Mono "+" and Mono "-" of the U.S.A. audio input card. Set the STEREO/MONO-MPX switch to MONO and adjust R8 to annul the signal on pin 14 of U2 (cmrr Common Mode Rejection Ratio).
Now, inject the mono signal at 0 dBm into the Mono "+" only (Mono "-" is connected to ground).
- 8) Connect an oscilloscope to pin 14 of U1 (with R8 in a central position) and adjust R40 for a reading of $8 V_{PP}$.
Set the STEREO/MONO-MPX switch (2 Fig.1) to STEREO, insert pilot tone (5 Fig.1) and make the same adjustment using R37.
- 9) Configure the FM modulation meter to measure deviation with 75KHz. If this is not the case, adjust trimmer R8 on the VCO for the right value.
- 10) Inject a 400 Hz signal at a level of -10 dBm ($0.775 V_{RMS}$ or $2.2 V_{PP}$ peak to peak for american versions) into the L and R inputs (trimmer R41 at maximum).
- 11) Set the STEREO/MONO-MPX switch (2 Fig.1) to STEREO, insert pilot tone (5 Fig.1) and fit jumper J3 to the Main card.
- 12) Connect an oscilloscope to pin 14 of U1 (with R8 in a central position) and adjust R28 for a reading of $8 V_{PP}$.
- 13) Now remove jumper JP3 and fit it to JP4. Adjust R35 for $8 V_{PP}$.

NOTE: The audio generator used for this test must have a distortion level of better than 0.001%.

Carry out this procedure at the normal operating frequency of the transmitter

5.5 CALIBRATION OF THE ANAMETER CARD

After replacement of the cards it is necessary to calibrate all the functions that they perform:

- 1) Connect a bypass wattmeter between the R.F. output and a 50 Ohm dummy load (show SETUP1 / Fig.4)
- 2) Adjust the output power for 2 W (5 or 10 W).
- 3) For each of the selector (13 Fig.1) positions adjust the corresponding trimmer for the values listed below:

READING	VALUE	FSD	TRIMMER	NOTE
+15V	15V	30V	R18	
+12V	12V	30V	R17	
+5V	5V	30V	R22	
PWR FWD	2W	2.5W	R21	0
EXT 24V (OPT)	24V	30V	R16	1
VPA	VARIABLE	30V	R15	2
IPA	VARIABLE	6A	R19	3
AFC	VARIABLE	30V	R20	4

NOTE:

- 0) Full scale deflection (FSD) is 10W for the 5 and 10W versions.
- 1) The reading is 0V if not fitted.
- 2) Use a multimeter to measure the voltage between Vp of Q1 (MJ3001 of the power supply card) and ground and check for the same reading on the internal meter.
- 3) For the IPA reading, use a 10 Ohm 5W resistor between Vp of Q1 (MJ3001 on the power supply card) and ground in series with an ammeter and check for the same reading on the internal meter.
- 4) Use a multimeter to read the AFC voltage (3-11V) on pin 2 of U7 on the Main card.

5.6 CALIBRATION OF THE CPU

After replacement, check that the displays function and that operating frequencies can be programmed using the UP (11 Fig.1), DOWN (8 Fig.1) and ENTER (9 Fig.1) buttons.

Check correct operation of the DB9 serial port (if fitted). No other checks are required.

5.7 CALIBRATION OF THE VCO

To calibrate the VCO, carry out the following procedure:

- 1) Connect the positive probe of a voltmeter to the glass capacitor (connected to the varicap) and the negative probe to ground.
- 2) Check that at both limits of the operating frequency band, the voltage reading lies between 3.5 and 10.3V. The higher frequency should correspond to the higher voltage and vice versa.
- 3) If the voltages in step 2. cannot be verified ie. the PLL is not locked, the soldered joint, connecting the SL strip-line to ground, should be moved (the other end of the strip-line is connected to the cathode of the varicap via capacitor CX).
- 4) Should the chosen operating frequency be less than 500 MHz, the strip-line will have been replaced by a piece of 50 Ohm teflon cable (RG316). In this case the varicap voltage may be adjusted by varying the length of the cable accordingly. The central conductor is shorted to the screen at one end of this cable.
- 5) If the calibration procedure is being carried out after a change of frequency, capacitor CX, situated on the VCO card, will also have to be changed according to table D.

<i>TABLE D</i>	
FREQUENCY RANGE	CX VALUE
220-300 MHz	1 nF
300-380 MHz	56-82 pF
380-400 MHz	33 pF
400-700 MHz	3.3-5.6 pF
700-980 MHz	3.3-5.6 pF

5.8 STEREO CODER ADJUSTMENT

After replacement of the Stereo Coder, the following procedure should be followed SETUP 3 (Fig.6):

- 1) Select 0 dBm with the INPUT LEVEL selector (with stereo coder and pilot tone inserted).
- 2) Connect a low distortion sine wave audio generator to the inputs L, R.
- 3) Connect the RF output of PTRL-NV/S3 to a suitable load (50 Ohm-20W).
- 4) Connect a -30 dB coupler to the RF input of F.A.M. (or other Modulation Analyzer type).

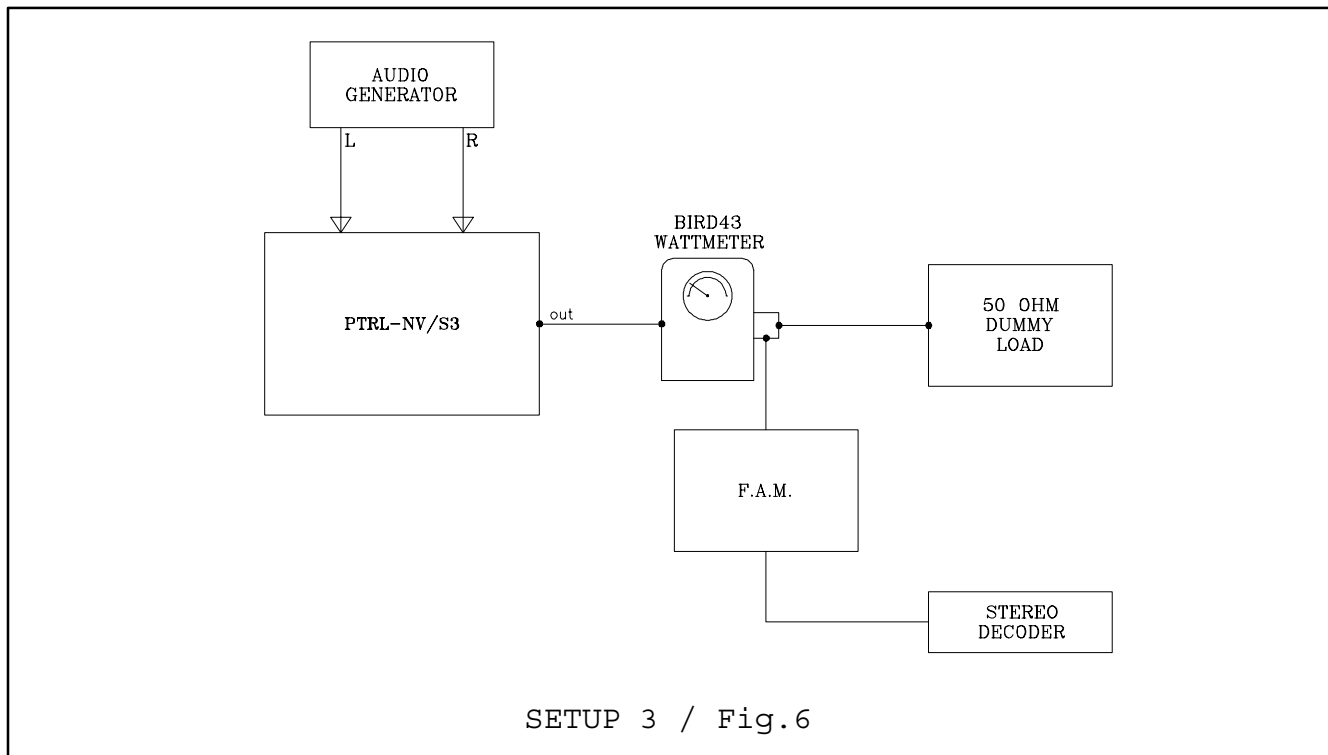

- 5) Connect to rear FM-MPX output of the F.A.M. a stereo measurement decoder.
- 6) Switch on the PTRL-NV/S3 and wait for the PLL to lock.
- 7) Set the output level of the signal generator to 0 dBm ($2.2 V_{PP}$ or $0.775 V_{RMS}$) and 400 Hz.
- 8) Select with the switch (13 Fig.1) the R(MONO) reading and if needed adjust P8 on the coder board for a 0 dB level.
- 8A) Repeat the same adjustment selecting L(MPX) adjusting P7.
- 9) Check with F.A.M. set in FM PK+ mode and with 30Hz-200KHz filter inserted that the deviation is 75 KHz; if necessary adjust R45 on the main card to obtain this value.
- 9A) Disconnect the audio signals on both channels and leave the PILOT TONE inserted; verify that a deviation of 6.5 to 7.5 KHz is present. This value can be adjusted with P6 on the coder board.
- 10) Disconnect the audio signal from one channel and verify that the output level of the audio generator is 0 dB.

On the stereo measure decoder, you should read a separation of more than 50 dB at 400 Hz.

Take the reading on the other channel.

If the separation between the two channels differs more than 3 dB, you can balance it adjusting P4 on the coder board.

SECTION 6

ALIGNMENT OF THE RADIO LINK

6.1 INTRODUCTION

This chapter details the alignment procedure for the PTRL-NV/S3 transmitter and the RXRL-NV receiver.

6.2 FREQUENCY ALIGNMENT

The operating frequency of the complete radio link (TX + RX) is set using a frequency meter to measure the frequency output by the transmitter and the frequency after the second conversion of the receiver.

It is recommended to align both units (TX and RX) at the same time and with the same frequency meter, preferably one of high precision (eg. ± 0.2 ppm). A difference greater than 2 KHz between the transmitter's center frequency and that of the receiver (measured at the intermediate frequency of 10.7 MHz) will result in degradation of audio quality and stereo separation.

To perform this alignment, carry out the following procedure (SETUP A1 and A2):

- 1) Connect the transmitter as shown in SETUP A1 (Fig.7).

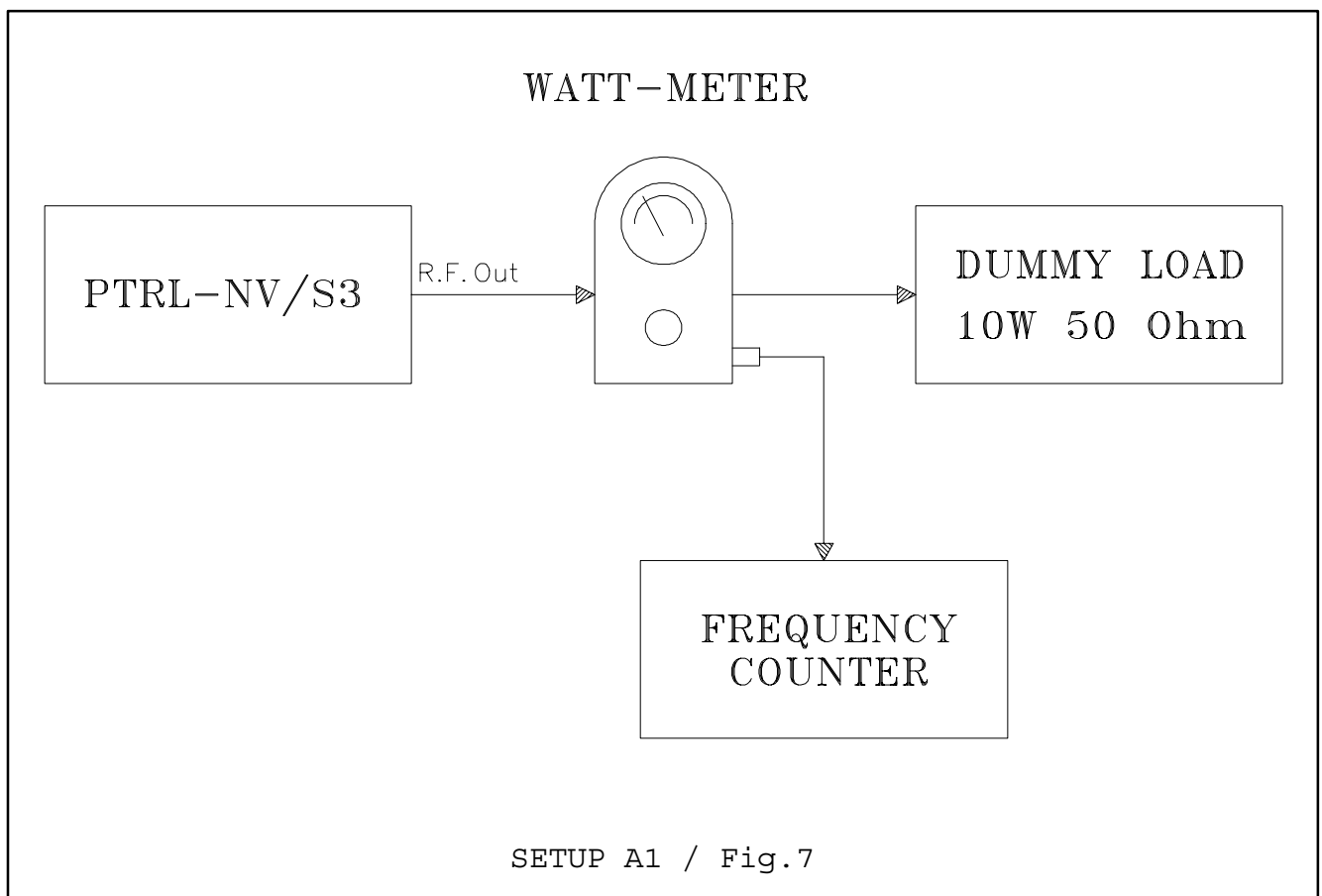

- 2) Switch on the transmitter and wait until it has locked to its operating frequency and the UNLOCK light goes out.
- 3) Connect through a wattmeter with sample a frequency meter and a dummy load, rated at 15W continuous, to the R.F. output situated on the rear panel of the transmitter.
- 4) Use the meter selector to select direct power measurement, FWD. Check that maximum output power (2W, 5W or 10W depending on the version) can be attained by turning the PWR ADJ control to its limit.
- 5) Using the frequency meter, check the output frequency of the transmitter and adjust as necessary with capacitors C68 and C69 situated on the Main card.
- 6) Connect the two units (TX and RX) as shown in SETUP A2 (Fig.8).

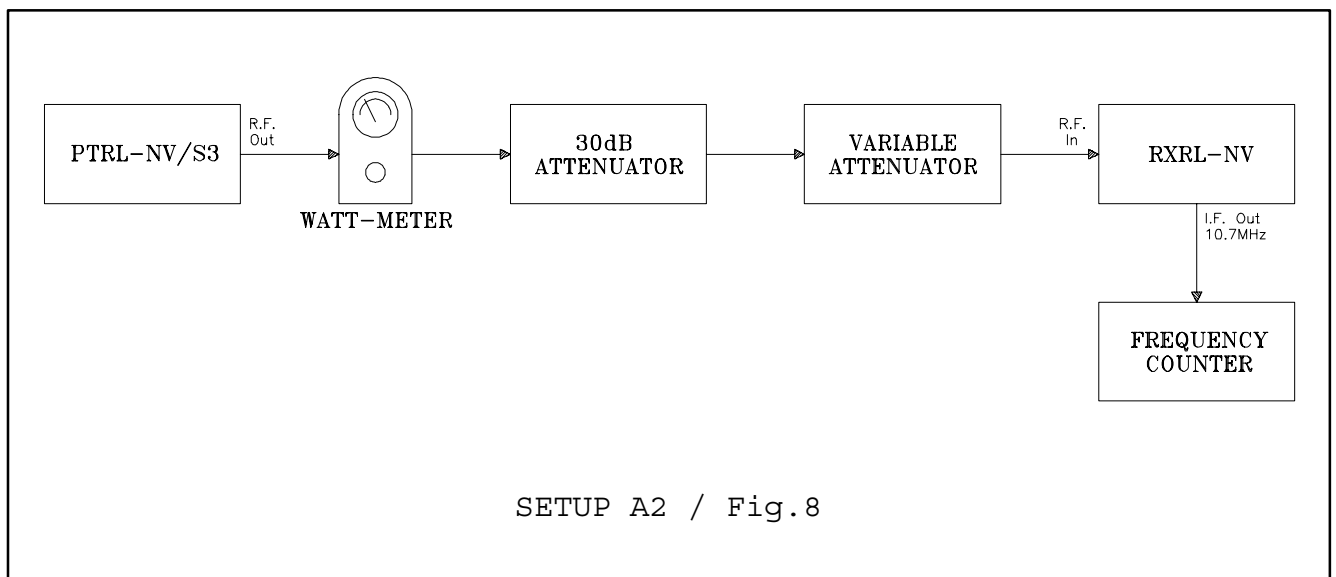

- 7) Adjust the variable attenuator for a value dependent from the transmitter's output power (Table E).

<i>TABLE E</i>			
PTRL-N.V. POWER	ATTENUATION	30dB ATTENUATOR	VALUE OF VARIABLE ATT
2 W	86 dB	30 dB	56 dB
5 W	90 dB	30 dB	60 dB
10 W	93 dB	30 dB	63 dB

Note : The attenuation values, above mentioned, are use to obtain a -53dBm signal on the receiver's R.F. Input

- 8) Connect the counter to the IF 10.7 MHz output and check that the frequency corresponds to this value, adjusting as necessary with capacitors C27 and C28 situated on the Synthetizer card for a frequency of 10.700 MHz \pm 2 KHz.
In this way, if the 10,7 MHz conversion is corrected, it means that the output frequency of the Front-End Mixer before the 70 MHz conversion has the same value of the output frequency of the transmitter.

6.3 MEASUREMENT OF RECEIVER'S S/N RATIO

The mono S/N (signal to noise) ratio is measured at the output of the receiver by feeding it with a 400 Hz modulating signal (± 75 KHz deviation) and comparing the output with the same output, under the same conditions, in the absence of the modulating signal, across the 30Hz/20 KHz band.

In the case of stereo modulation, the S/N ratio will be measured on single channels (left and right) decoded and de-emphasized.

Both mono and stereo measurements should be taken having configured the unit according to SETUP B1 and B2 and carrying out the following procedure:

- 1) Connect the instruments as shown in SETUP B1 (Fig.9) to make MONO measurement.

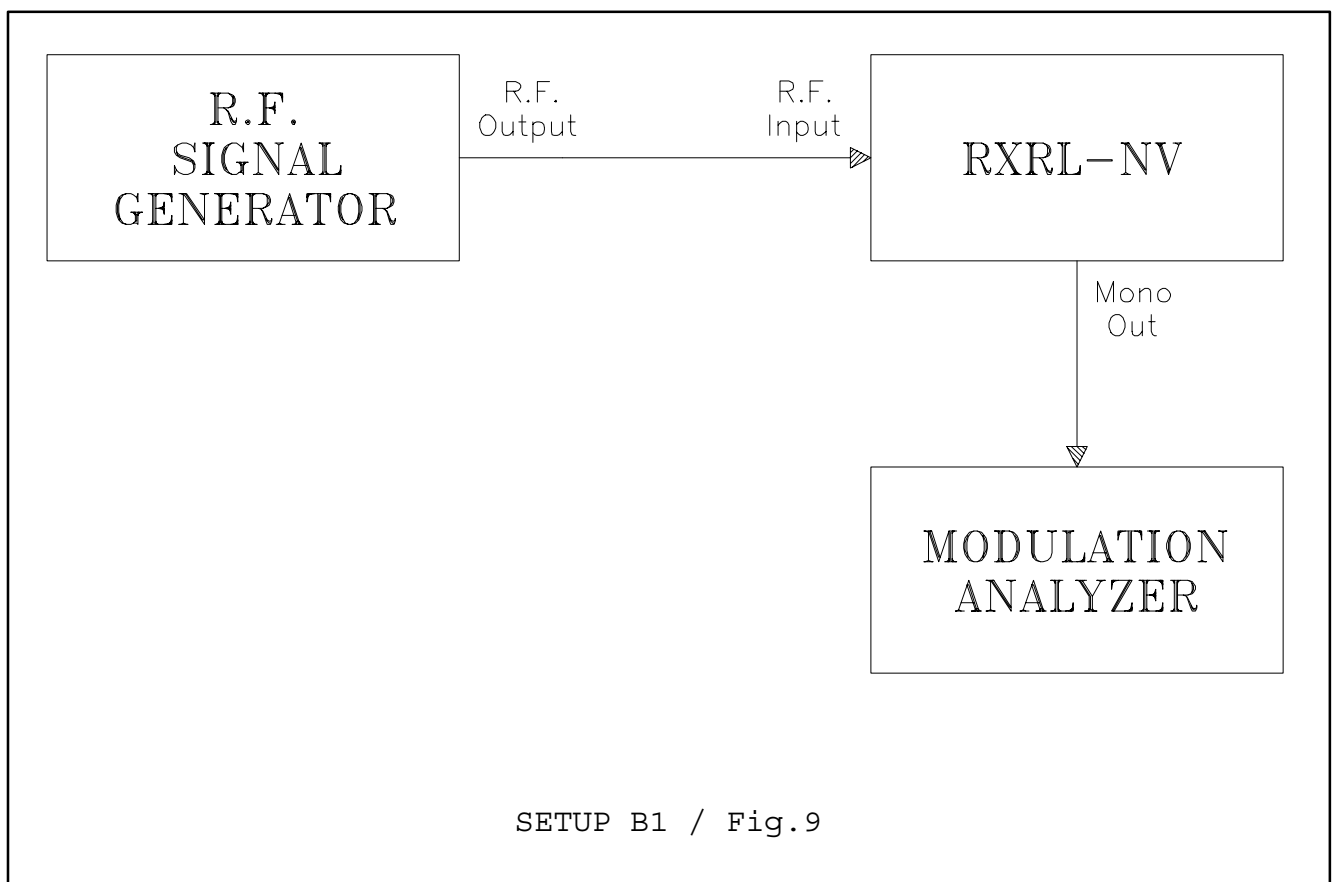

- 2) Generate an R.F. carrier at operating frequency and -67 dBm; modulate the carrier with a 400 Hz tone with a ± 75 KHz deviation. Inject the resultant R.F. signal into the receiver input.
- 3) Using the FAM modulation analyzer, check that the S/N ratio of the RXRL-NV receiver is better than 65 dB, referred to a deviation of ± 75 KHz.
- 4) Connect the instruments as shown in SETUP B2 (Fig.10) to make the STEREO measurement.
- 5) Adjust the signal generator output for a level of 1mV (the carrier and deviation will remain constant).

- 6) Use the modulation analyzer to make the S/N measurement and check that the figure is better than 60 dB for the RXRL-NV.

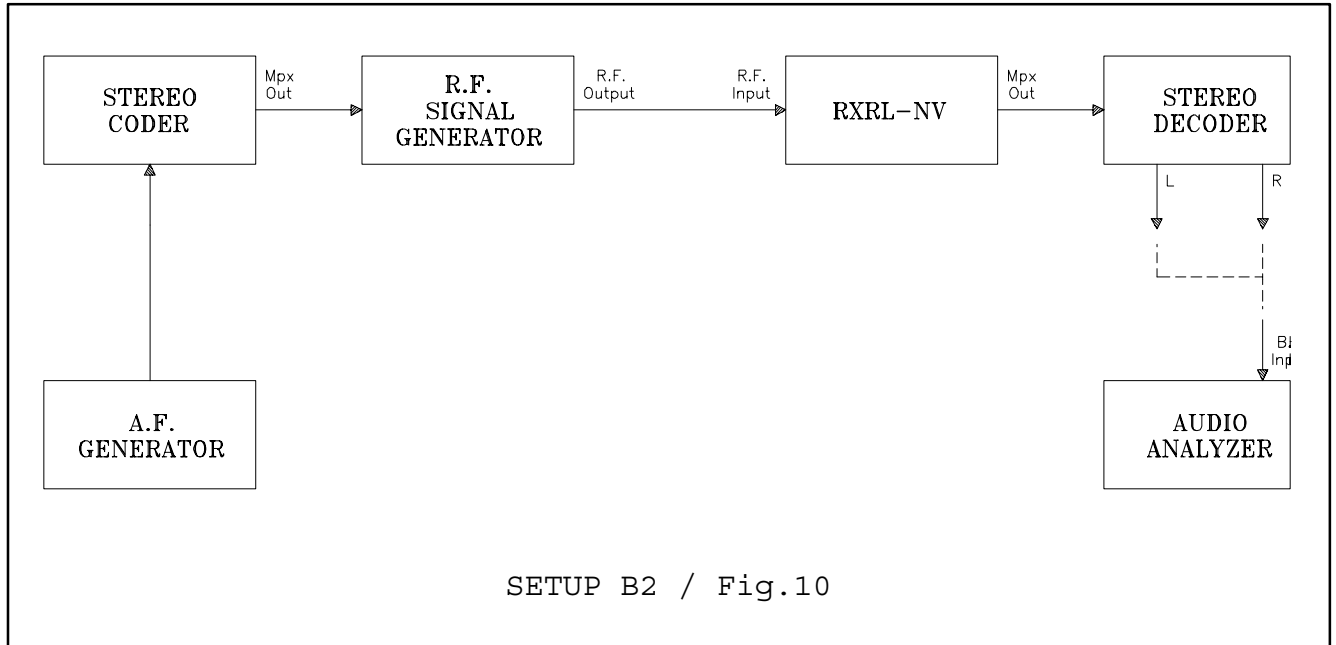

6.4 STEREO SEPARATION

Stereo separation is measured using a stereo coder, a stereo demodulator. The figure is obtained from the ratio of the left and right channel outputs with only the left channel modulated, for frequencies between 30 Hz and 15 KHz.

To make this measurement, configure the unit according to SETUP C (Fig.11) and carry out the following procedure:

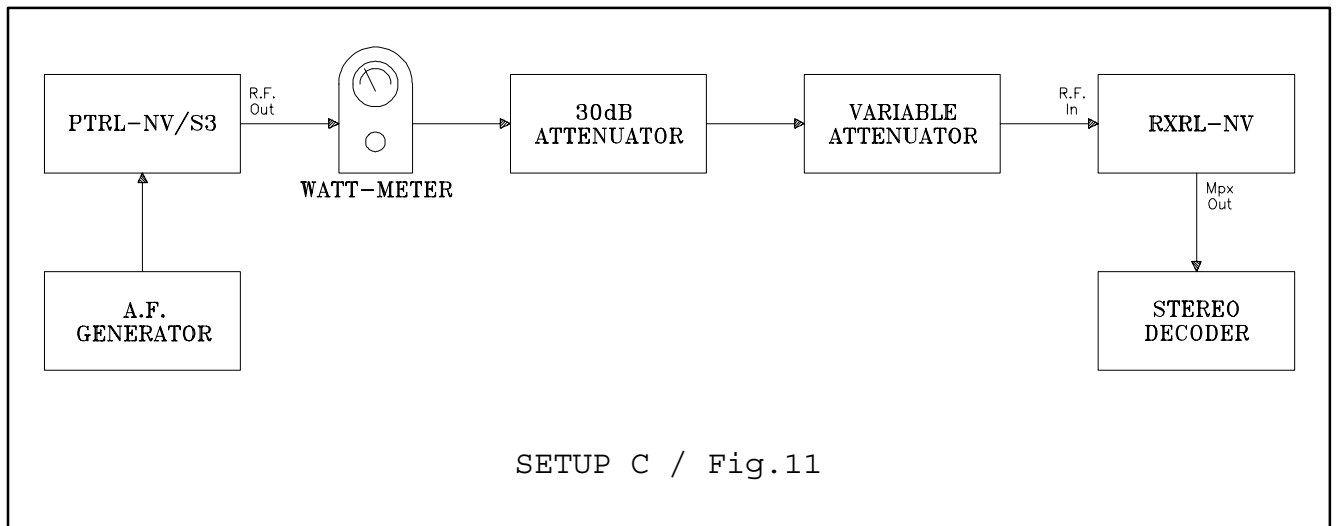

- 1) Adjust the variable attenuator for a value dependent from the transmitter's output power (Table E).

<i>TABLE E</i>			
PTRL-N.V. POWER	ATTENUATION	30dB ATTENUATOR	VALUE OF VARIABLE ATT
2 W	86 dB	30 dB	56 dB
5 W	90 dB	30 dB	60 dB
10 W	93 dB	30 dB	63 dB

Note : The attenuation values, above mentioned, are use to obtain a -53dBm signal on the receiver's R.F. Input

- 2) Adjust the signal generator for an output level of -10 dBm at the right input (and subsequently the left) of the stereo coder.
- 3) Check that the reading from the output of the stereo decoder is better or equal to 47 dB (both at 400 Hz and 10 KHz).
- 4) Repeat the operation for both channels with a modulating tone of 400 Hz and 10 KHz. The maximum difference should be ± 3 dB.

6.5 CHANGING FREQUENCY

There are three different procedures for changing frequency, depending on the new frequency to be selected:

CASE A

Should the new frequency fall within the range selectable by the CPU (and without the requirement of a change of EPROM), the following procedure should be carried out:

TRANSMITTER

- 1) Select the new frequency with the UP (11 Fig.1) and DOWN (8 Fig.1) buttons and confirm it with the ENTER (9 Fig.1) key.

RECEIVER

- 1) Select the new frequency with the UP and DOWN buttons and confirm it with the ENTER key.
- 2) Select the SIGNAL measurement using the selector and confirmed by the corresponding green led.
- 3) Calibrate the 6 compensators, situated on the two filters FIL1 and FIL2 of the Front-end Mixer, for the maximum R.F. signal, checking against the corresponding reading on the receiver's meter (maximum R.F. signal displayable = -47 dBm).

CASE B

THIS PROCEDURE SHOULD ONLY BE CARRIED OUT BY QUALIFIED PERSONNEL USING THE CORRECT TEST EQUIPMENT. ERRORS CAN CAUSE SERIOUS DAMAGE TO EQUIPEMENT AND WILL AUTOMATICALLY NULLIFY THE WARRANTY.

Should the new operating frequency fall within one of the two adjacent bands (higher or lower), the following procedure should be carried out:

TRANSMITTER

- 1) Change the EPROM for one containing the desired frequency.

- 2) After the replacement of the EPROM, set the CPU on the frequency range relative to the EPROM frequency. When the transmitter switches on, appears on the display the lightening notice SET 0; now, push ENTER and verify that the minimum frequency of the EPROM appears on the display.
In case in which appears the lightening notice SET 1 too, push again ENTER command.
- 3) Select the new frequency using the UP (11 Fig.1) and DOWN (8 Fig.1) buttons and confirm it with the ENTER (9 Fig.1) key.
- 4) Follow the calibration procedure for the VCO, as detailed in paragraph "Calibration of the VCO" of the PTRL-NV/S3 manual.
- 5) Follow the calibration procedure for the final power stage, as detailed in paragraph "Calibration of the R.F. power amplifier" of the PTRL-NV manual to optimize the output power.

RECEIVER

- 1) Change the EPROM for one containing the desired frequency.
- 2) After the replacement of the EPROM, set the CPU on the frequency range relative to the EPROM frequency. When the receiver switches on, appears on the display the lightening notice SET 0; now, push ENTER and verify that the minimum frequency of the EPROM appears on the display.
In case in which appears the lightening notice SET 1 too, push again ENTER command.
- 3) Select the new frequency using the UP and DOWN buttons and confirm it with the ENTER key.
- 4) Calibrate the VCO as detailed in paragraph "Calibration of the VCO" of the RXRL-NV manual.
- 5) Select the SIGNAL measurement using the selector and confirmed by the corresponding green led.
- 6) Calibrate the 6 compensators, situated on the two filters FIL1 and FIL2 of the Front-end Mixer, for the maximum R.F. signal, checking against the corresponding reading on the receiver's meter (maximum R.F. signal displayable = -47 dBm).

CASE C

THIS PROCEDURE SHOULD ONLY BE CARRIED OUT BY QUALIFIED PERSONNEL USING THE CORRECT TEST EQUIPMENT.

ERRORS CAN CAUSE SERIOUS DAMAGE TO EQUIPMENT AND WILL AUTOMATICALLY NULLIFY THE WARRANTY.

Should the new operating frequency fall within a non-adjacent band the following procedure should be carried out:

TRANSMITTER

- 1) Change the EPROM for one containing the desired frequency.
- 2) After the replacement of the EPROM, set the CPU on the frequency range relative to the EPROM frequency. When the transmitter switches on, appears on the display the lightning notice SET 0; now, push ENTER and verify that the minimum frequency of the EPROM appears on the display. In case in which appears the lightning notice SET 1 too, push again ENTER command.
- 3) Select the new frequency using the UP (11 Fig.1) and DOWN (8 Fig.1) buttons and confirm it with the ENTER (9 Fig.1) key.
- 4) Follow the procedure for calibrating or replacing the VCO as detailed in paragraph "Calibration of the VCO" and paragraph "Main card replacement" of the PTRL-NV/S3 manual.
- 5) Follow the procedure for calibrating or replacing the final power stage as detailed in paragraphs "Calibration of the R.F. power amplifier" and paragraph "R.F. power amplifier replacement" of the PTRL-NV/S3 manual.

RECEIVER

- 1) Change the EPROM for one containing the desired frequency.
- 2) Replace the Front-end Mixer (if the new frequency requires it) as detailed in paragraph "Replacement of the front-end mixer" of the RXRL-NV manual.
- 3) Replace the VCO (if the new frequency requires it) as detailed in paragraph "Replacement of the PLL" of the RXRL-NV manual.
- 4) After the replacement of the EPROM, set the CPU on the frequency range relative to the EPROM frequency. When the receiver switches on, appears on the display the lightning notice SET 0; now, push ENTER and verify that the minimum frequency of the EPROM appears on the display.
In case in which appears the lightning notice SET 1 too, push again ENTER command.
- 5) Select the SIGNAL measurement using the selector and confirmed by the corresponding green led.
- 6) Select the new frequency using the UP and DOWN buttons and confirm it with the ENTER key.

- 7) Calibrate the VCO as detailed in paragraph "Calibration of the VCO" of the RXRL-NV manual.
- 8) Calibrate the 6 compensators, situated on the two filters FIL1 and FIL2 of the Front-end Mixer, for the maximum R.F. signal, checking against the corresponding reading on the receiver's meter (maximum R.F. signal displayable = -47 dBm).

6.6 TRANSMITTER AUDIO DEVIATION AND DISTORTION FIGURES

To make this measurement, configure the unit according to SETUP D (Fig.12) and carry out the following procedures:

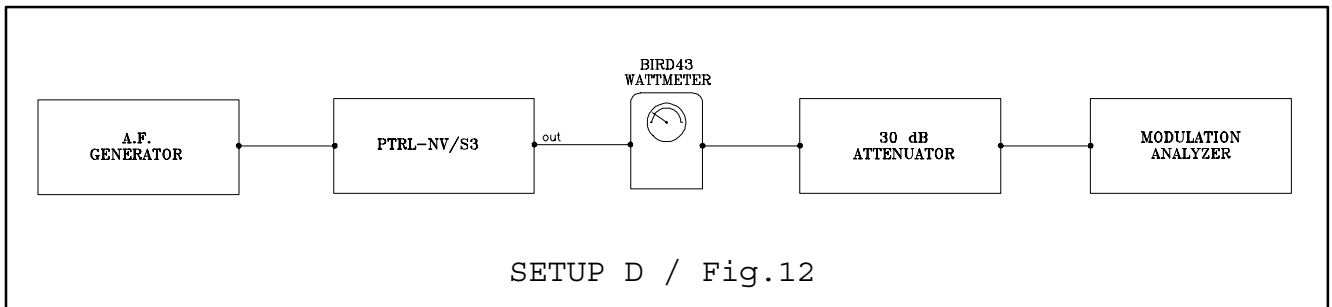

- 1) Adjust the signal generator for a signal level of -10 dBm (0dBm for american versions) at the MONO and STEREO inputs.
- 2) Configure the modulation analyzer to rear deviation (P+).
- 3) Check that the deviation reading for the PTRL-NV/S3 is 75 KHz and if not, adjust trimmer R8 (inside the VCO) to obtain it.
- 4) Configure the audio analyzer to read distortion (with 50 uS de-emphasis for european versions and 75 uS for american versions).
- 5) Check that the distortion figure is better than 0.05% with low-pass and high-pass filters of 20 KHz and 30 Hz respectively, for both MONO and STEREO inputs.

APPENDIX A

CIRCUIT DIAGRAMS, LAYOUTS AND BILLS OF MATERIAL

This section contains circuit diagrams, layouts and bills of material of the modules which composing the equipment. For more information about each module see as reference Section 2.

MAIN CARD

- 1) "PLL Section" Circuit Diagram
- 2) "PLL Section" Bill of Materials
- 3) "AF Section" Circuit Diagram
- 4) "AF Section" Bill of Materials
- 5) Main Card Components Layout

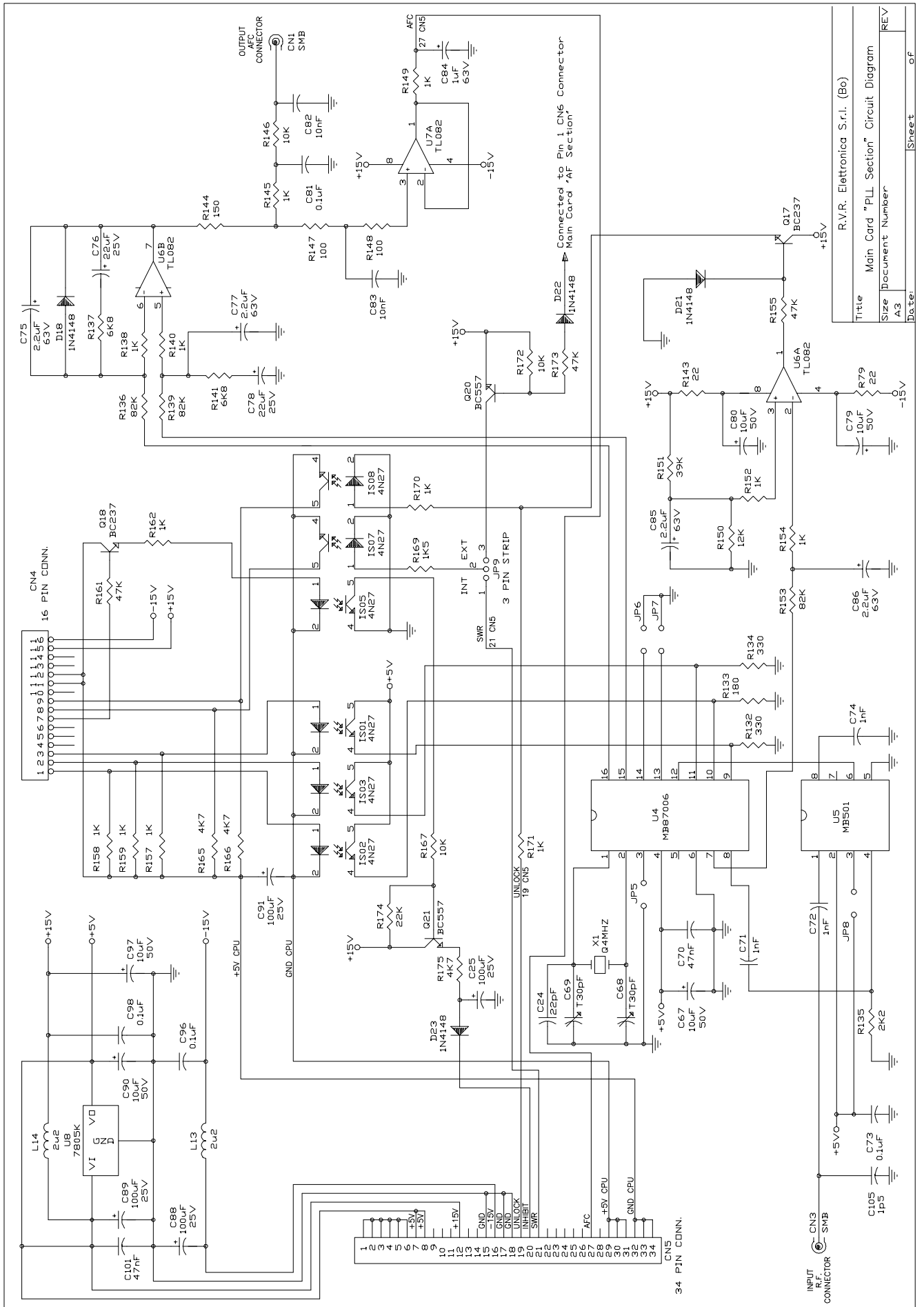

R.V.R. Elettronica S.r.l. (Bo)	
Title	Main Card "PLL Section" Circuit Diagram
Size	A3
Document Number	REV
Date:	Sheet of

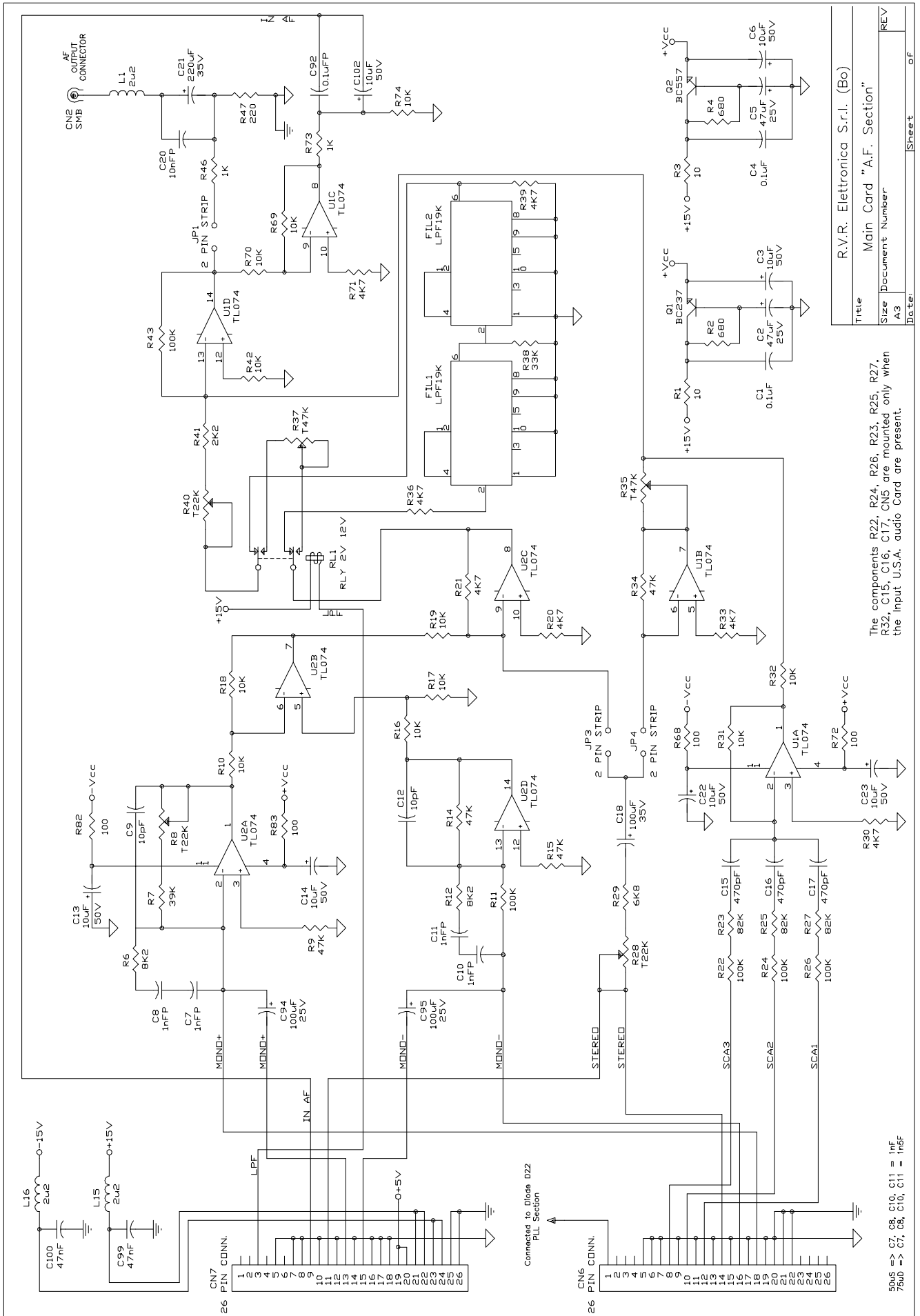

Title		R.V.R. Elettronica S.r.l. (Bo)	
Size		Main Card "A.F. Section"	
A3	Document Number		
	Date:	Sheet	of

The components R22, R24, R26, R23, R25, R27, R32, C15, C16, C17, C85 are mounted only when the Input U.S.A. audio Card are present.

50uS => C7, C8, C10, C11 = 1nF
75uS => C7, C8, C10, C11 = 1n5F

Main Card "P.L.L. Section"				Bill of Materials	Pag. 1
Item	Quantity	Reference	Part	Description	Part Order Code
1	2	R79,R143	22	RESISTOR 1/4W 5%	RSC1/4JH0022
2	2	R147,R148	100	RESISTOR 1/4W 5%	RSC1/4JH0100
3	1	R144	150	RESISTOR 1/4W 5%	RSC1/4JH0150
4	1	R133	180	RESISTOR 1/4W 5%	RSC1/4JH0180
5	2	R132,R134	330	RESISTOR 1/4W 5%	RSC1/4JH0330
6	12	R138,R140, R145,R149, R152,R154, R157,R158, R159,R162, R170,R171	1K	RESISTOR 1/4W 5%	RSC1/4JK0001
7	1	R169	1K5	RESISTOR 1/4W 5%	RSC1/4JK01,5
8	1	R135	2K2	RESISTOR 1/4W 5%	RSC1/4JK02,2
9	3	R165,R166, R175	4K7	RESISTOR 1/4W 5%	RSC1/4JK04,7
10	2	R137,R141	6K8	RESISTOR 1/4W 5%	RSC1/4JK06,8
11	3	R146,R167, R172	10K	RESISTOR 1/4W 5%	RSC1/4JK0010
12	1	R150	12K	RESISTOR 1/4W 5%	RSC1/4JK0012
13	1	R174	22K	RESISTOR 1/4W 5%	RSC1/4JK0022
14	1	R151	39K	RESISTOR 1/4W 5%	RSC1/4JK0039
15	3	R155,R161, R173	47K	RESISTOR 1/4W 5%	RSC1/4JK0047
16	3	R136,R139, R153	82K	RESISTOR 1/4W 5%	RSC1/4JK0082
17	1	C105	1p5	CERAMIC CAPACITOR NP0	CKM1,5BJ600C
18	1	C24	22pF	CERAMIC CAPACITOR NP0	CKM220BJ600C
19	2	C68,C69	T30pF	TRIMMER CAPACITOR	CVC300BK600
20	3	C71,C72, C74	1nF	CERAMIC CAPACITOR	CKM102BK600P
21	2	C82,C83	10nF	CERAMIC CAPACITOR	CKM103BK600P
22	2	C70,C101	47nF	CERAMIC CAPACITOR	CKM473BK600P
23	4	C73,C81, C96,C98	0.1uF	CERAMIC CAPACITOR	CKM104BK600P
24	1	C84	1uF	ELECTROLYTIC CAPACITOR	CEA105AM6302

Main Card "P.L.L. Section"				Bill of Materials	Pag. 2
Item	Quantity	Reference	Part	Description	Part Order Code
25	4	C75,C77, C85,C86	2.2uF	ELECTROLYTIC CAPACITOR	CEA225AM630
26	5	C67,C79, C80,C90, C97	10uF	ELECTROLYTIC CAPACITOR	CEA106AM350
27	2	C76,C78	22uF	ELECTROLYTIC CAPACITOR	CEA226BM350
28	4	C25,C88, C89,C91	100uF	ELECTROLYTIC CAPACITOR	CEA107BM350
29	2	L13,L14	2u2	RF CHOKE	IMP02U2A
30	4	JP5,JP6, JP7,JP8	2 P STRIP	STRIP M P 2.54 2 PIN	CNTSTRIPMCS
31	1	JP9	3 P STRIP	STRIP M P 2.54 3 PIN	CNTSTRIPMCS
32	1	CN4	16 P CONN	CONN. M 2*8 P 2.54	CNTMCSFC16P
33	1	CN5	34 P CONN	CONN. M 2*17 P 2.54	CNTMCSFC34P
34	2	CN1,CN3	SMB	CONN. SMB CRIMP. RG188	CNTSMBFCVD
35	1	X1	Q4MHZ	CRYSTAL	QRZ4HC18
36	4	D18,D21, D22,D23	1N4148	SILICON DIODE	DIS1N4148
37	6	IS01,IS02, IS03,IS05, IS07,IS08	4N27	PHOTOCOUPLER	LED4N27
38	1	U8	7805K	POS. STABILIZER 1.5A	CIL7805K
39	2	Q17,Q18	BC237	NPN TRANSISTOR	TRNBC237
40	2	Q20,Q21	BC557	PNP TRANSISTOR	TRNBC557
41	2	U6,U7	TL082	DOUBLE OP. AMP.	CILTL082
42	1	U5	MB501	DUAL MOD. PRESCALER	CIDMB501
43	1	U4	MB87006	INTEGRATED DIVIDER PLL	CIDMB87006

Main Card "A.F. Section"				Bill of Materials	Pag. 1
Item	Quantity	Reference	Part	Description	Part Order Code
1	2	R1,R3	10	RESISTOR 1/4W 5%	RSC1/4JH0010
2	4	R68,R72, R82,R83	100	RESISTOR 1/4W 5%	RSC1/4JH0100
3	1	R47	220	RESISTOR 1/4W 5%	RSC1/4JH0220
4	2	R2,R4	680	RESISTOR 1/4W 5%	RSC1/4JH0680
5	2	R46,R73	1K	RESISTOR 1/4W 5%	RSC1/4JK0001
6	1	R41	2K2	RESISTOR 1/4W 5%	RSC1/4JK02,2
7	7	R20,R21, R30,R33, R36,R39, R71	4K7	RESISTOR 1/4W 5%	RSC1/4JK04,7
8	1	R29	6K8	RESISTOR 1/4W 5%	RSC1/4JK06,8
9	2	R6,R12	8K2	RESISTOR 1/4W 5%	RSC1/4JK08,2
10	11	R10,R16, R17,R18, R19,R31, R32,R42, R69,R70,R74	10K	RESISTOR 1/4W 5%	RSC1/4JK0010
11	1	R38	33K	RESISTOR 1/4W 5%	RSC1/4JK0033
12	1	R7	39K	RESISTOR 1/4W 5%	RSC1/4JK0039
13	4	R9,R14, R15,R34	47K	RESISTOR 1/4W 5%	RSC1/4JK0047
14	3	R23,R25, R27	82K	RESISTOR 1/4W 5%	RSC1/4JK0082
15	5	R11,R22, R24,R26,R43	100K	RESISTOR 1/4W 5%	RSC1/4JK0100
16	3	R8,R28,R40	T22K	TRIMM.REG.VERT. 10mm	RVTD10VK0022
17	2	R35,R37	T47K	TRIMM.REG.VERT. 10mm	RVTD10VK0047
18	2	C9,C12	10pF	CERAMIC CAPACITOR NP0	CKM100BJ600C
19	3	C15,C16, C17	470pF	CERAMIC CAPACITOR	CKM471BK600P
20	4	C7,C8, C10,C11	1nFP	POLIESTER CAPACITOR	CPE102BK161
21	1	C20	10nFP	POLIESTER CAPACITOR	CPE103BJ101
22	2	C99,C100	47nF	CERAMIC CAPACITOR	CKM473BK600P
23	2	C1,C4	0.1uF	CERAMIC CAPACITOR	CKM104BK600P

Main Card "A.F. Section"				Bill of Materials	Pag. 2
Item	Quantity	Reference	Part	Description	Part Order Code
24	1	C92	0.1uFP	POLIELSTER CAPACITOR	CPE104DK101
25	7	C3,C6,C13, C14,C22, C23,C102	10uF	ELECTROLYTIC CAPACITOR	CEA106AM350
26	2	C2,C5	47uF	ELECTROLYTIC CAPACITOR	CEA476BM630
27	3	C18,C94, C95	100uF	ELECTROLYTIC CAPACITOR	CEA107BM350
28	1	C21	220uF	ELECTROLYTIC CAPACITOR	CEA227BM350
29	3	L1,L15,L16	2u2	RF CHOKE	IMP02U2A
30	2	FIL1,FIL2	LPF19K	LOW PASS FILTER 19KHZ	FLP19KHZ
31	3	JP1,JP3, JP4	2 P STRIP	STRIP M P 2.54 2 PIN	CNTSTRIPMCS
32	2	CN6,CN7	26 P CONN	CONN. M 2*13 P 2.54	CNTMCSFC26P
33	1	CN2	SMB	CONN. SMB CRIMP. RG188	CNTSMBFCVD
34	1	RL1	RL2V12V	RELAY 2 VIE 12V	RLDLFHA00212
35	1	Q1	BC237	NPN TRANSISTOR	TRNBC237
36	1	Q2	BC557	PNP TRANSISTOR	TRNBC557
37	2	U1,U2	TL074	QUAD OP. AMP.	CILTL074

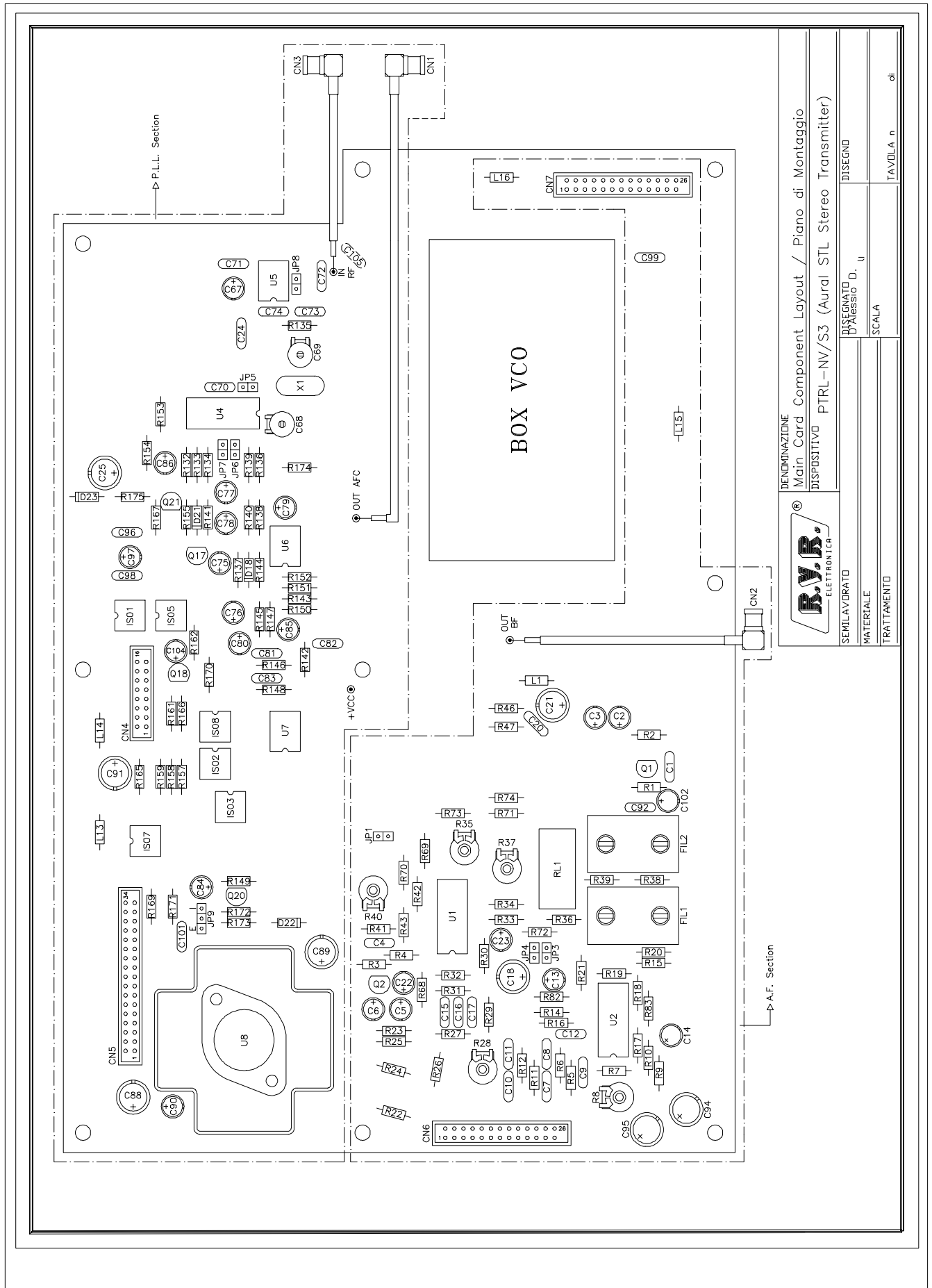

V.C.O. CARD

- A) Circuit Diagram
- B) Bill of Materials
- C) Layouts

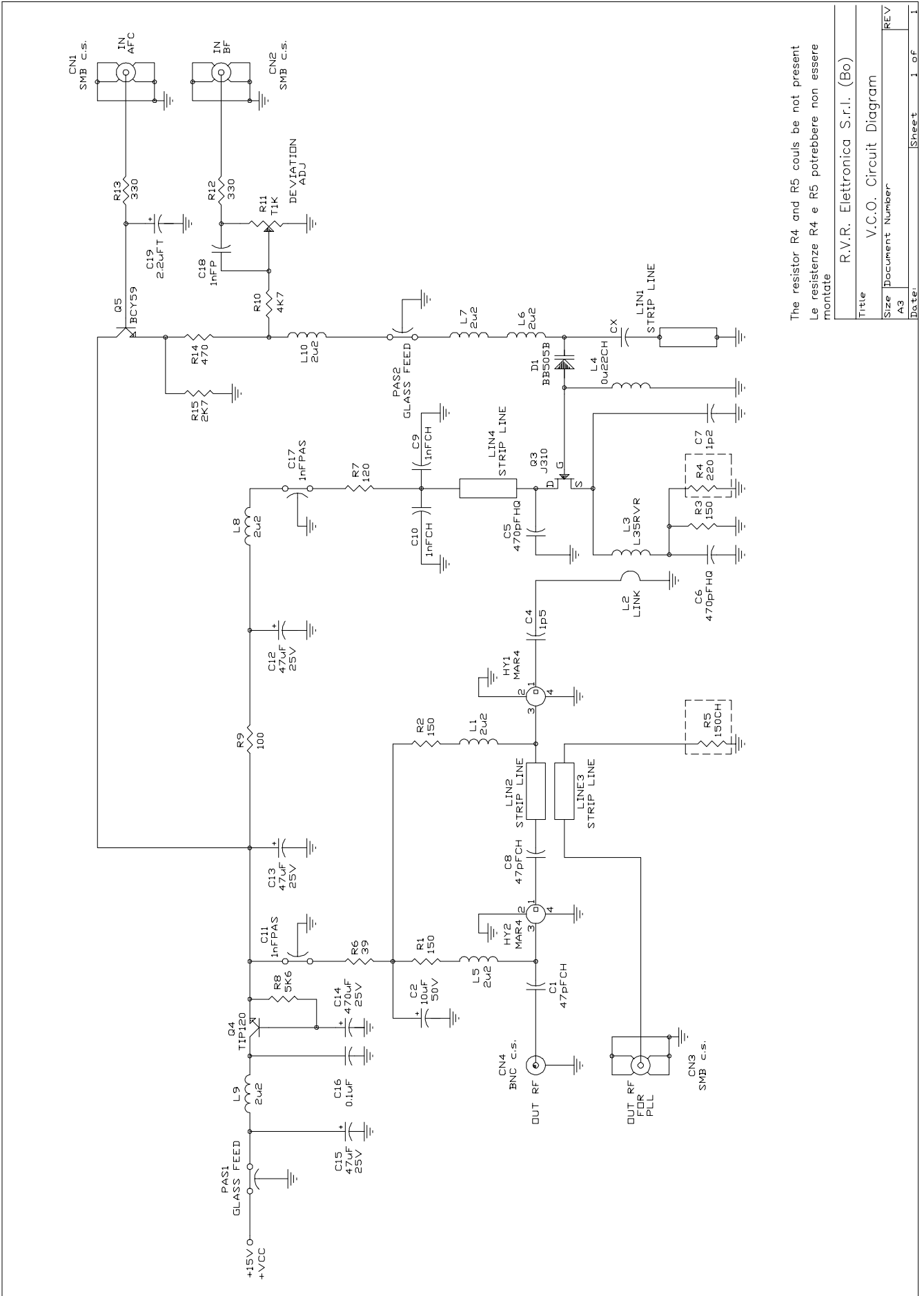



The resistor R4 and R5 could be not present
 Le resistenze R4 e R5 potrebbero non essere
 montate

Title		R.V.R. Elettronica S.r.l. (Bo)	
Size		V.C.O. Circuit Diagram	
Document Number		REV	
Date		Sheet	1 of 1

V.C.O. Card			Bill of Materials		Pag. 1
Item	Quantity	Reference	Part	Description	Part Order Code
1	1	R6	39	RESISTOR 1/4W 5%	RSC1/4JH0039
2	1	R9	100	RESISTOR 1/4W 5%	RSC1/4JH0100
3	1	R7	120	RESISTOR 1/4W 5%	RSC1/4JH0120
4	1	R5	150CH	CHIP RESISTOR	RCC1/4JH0150
5	3	R1,R2,R3	150	RESISTOR 1/4W 5%	RSC1/4JH0150
6	1	R4	220	RESISTOR 1/4W 5%	RSC1/4JH0220
7	2	R12,R13	330	RESISTOR 1/4W 5%	RSC1/4JH0330
8	1	R14	470	RESISTOR 1/4W 5%	RSC1/4JH0470
9	1	R15	2K7	RESISTOR 1/4W 5%	RSC1/4JK02,7
10	1	R10	4K7	RESISTOR 1/4W 5%	RSC1/4JK04,7
11	1	R8	5K6	RESISTOR 1/4W 5%	RSC1/4JK05,6
12	1	R11	T1K	TRIMM.REG.VERT. 10mm	RVTD10VK0001
13	2	PAS1,PAS2	GLASS FEED	PASSANTE IN VETRO	PASSVETRO
14	1	C7	1p2	CERAMIC CAPACITOR NP0	CKM1,2BJ600C
15	1	C4	1p5	CERAMIC CAPACITOR NP0	CKM1,5BJ600C
16	2	C1,C8	47pFCH	CERAMIC CHIP CAPACITOR	CCC470AJ500
17	2	C5,C6	470pFHQ	HIGHT Q CAPACITOR	CHQ471AJ500
18	2	C9,C10	1nFCH	CERAMIC CHIP CAPACITOR	CCC102AJ500
19	2	C11,C17	1nFPAS	CERAMIC THROUGH CAPAC.	CDP102XK500
20	1	C18	1nFP	POLIESTER CAPACITOR	CPE102BK161
21	1	C16	0.1uF	CERAMIC CAPACITOR	CKM104BK600P
22	1	C19	2.2uFT	TANTALIUM CAPACITOR	CET225AM350
23	1	C2	10uF	ELECTROLYTIC CAPACITOR	CEA106AM350
24	3	C12,C13, C15	47uF	ELECTROLYTIC CAPACITOR	CEA476BM630
25	1	C14	470uF	ELECTROLYTIC CAPACITOR	CEA477BM350
26	1	L4	0u22CH	CHIP RF CHOKE	
27	7	L1,L5,L6, L7,L8, L9,L10	2u2	RF CHOKE	IMP02U2A

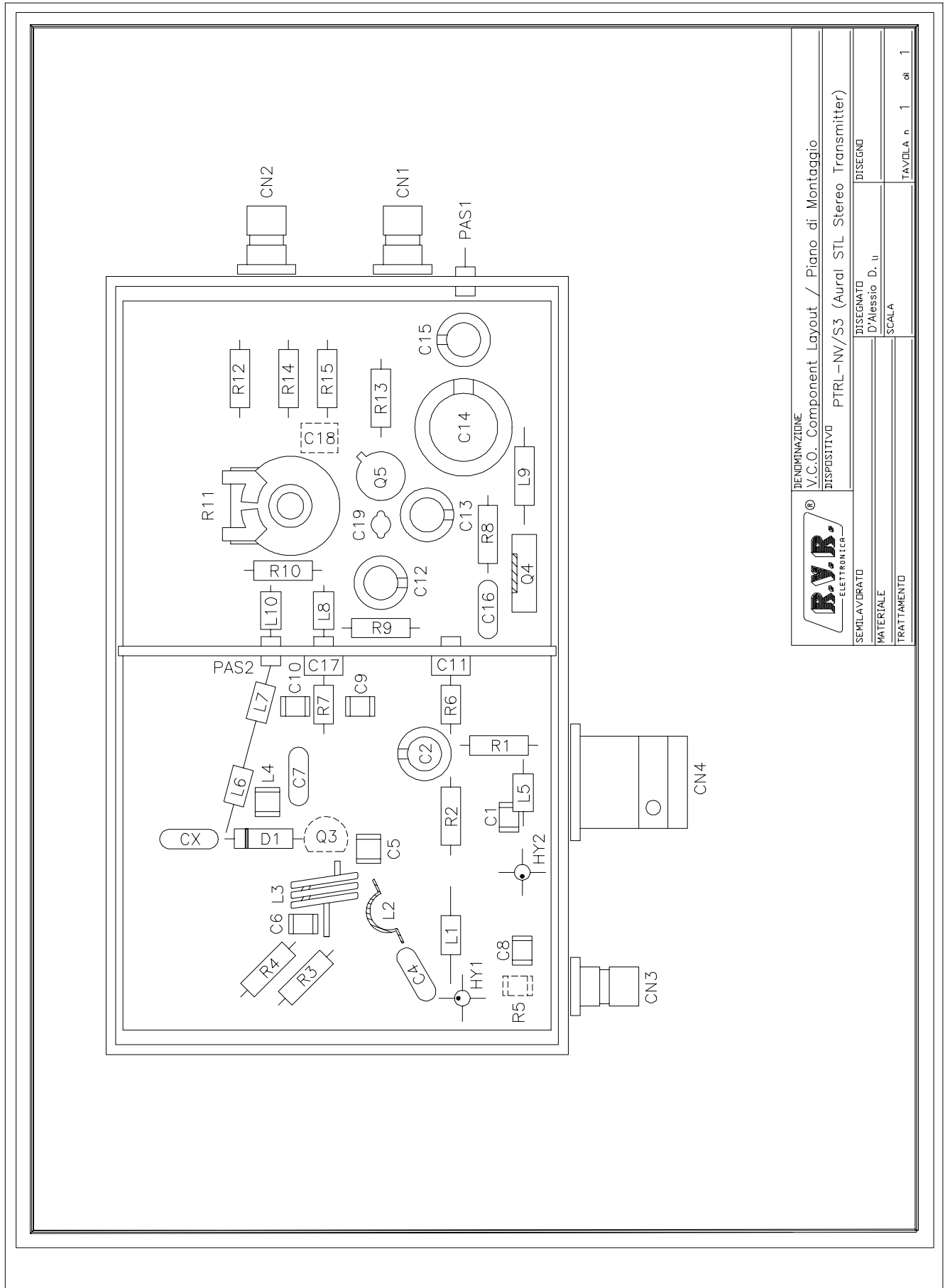
V.C.O. Card			Bill of Materials		Pag. 2
Item	Quantity	Reference	Part	Description	Part Order Code
28	1	L3	L35RVR	3 SP DIA 5	
29	1	L2	LINK	LINK FILO ARG. 1mm	CAVARG1000
30	1	CN4	BNC C.S.	CONN. BNC A STAMPATO	CNTBNCFCSD
31	3	CN1,CN2, CN3	SMB C.S.	CONN. SMB A STAMPATO	CNTSMBMCSD
32	1	D1	BB505B	VARICAP DIODE	DIVBB505
33	1	Q5	BCY59	NPN TRANSISTOR	TRNBCY59
34	1	Q4	TIP120	NPN DARLINGTON	TRNTIP120
35	1	Q3	J310	FET TRANSISTOR	TRNJ310
36	2	HY1,HY2	MAR4	HYBRID AMP MAR4	MIBMAR4
37	1	CX	N.C.	NOT CONNECTED	
38	4	LIN1,LIN2, LINE3,LIN4	STRIP LINE	STRIP LINE	



		DENOMINAZIONE V.C.O. Component Layout / Piano di Montaggio	
SEMILAVORATO		DISPOSITIVO PTRL-NV/S3 (Aural STL Stereo Transmitter)	
MATERIALE		DISEGNATO D'Alessio D. U.	
TRATTAMENTO		SCALA	
		TAVOLA n. 1 di 1	

C.P.U. CARD

- A) BlockDiagram
- B) Circuit Diagram
- C) Bill of Materials
- D) Layout

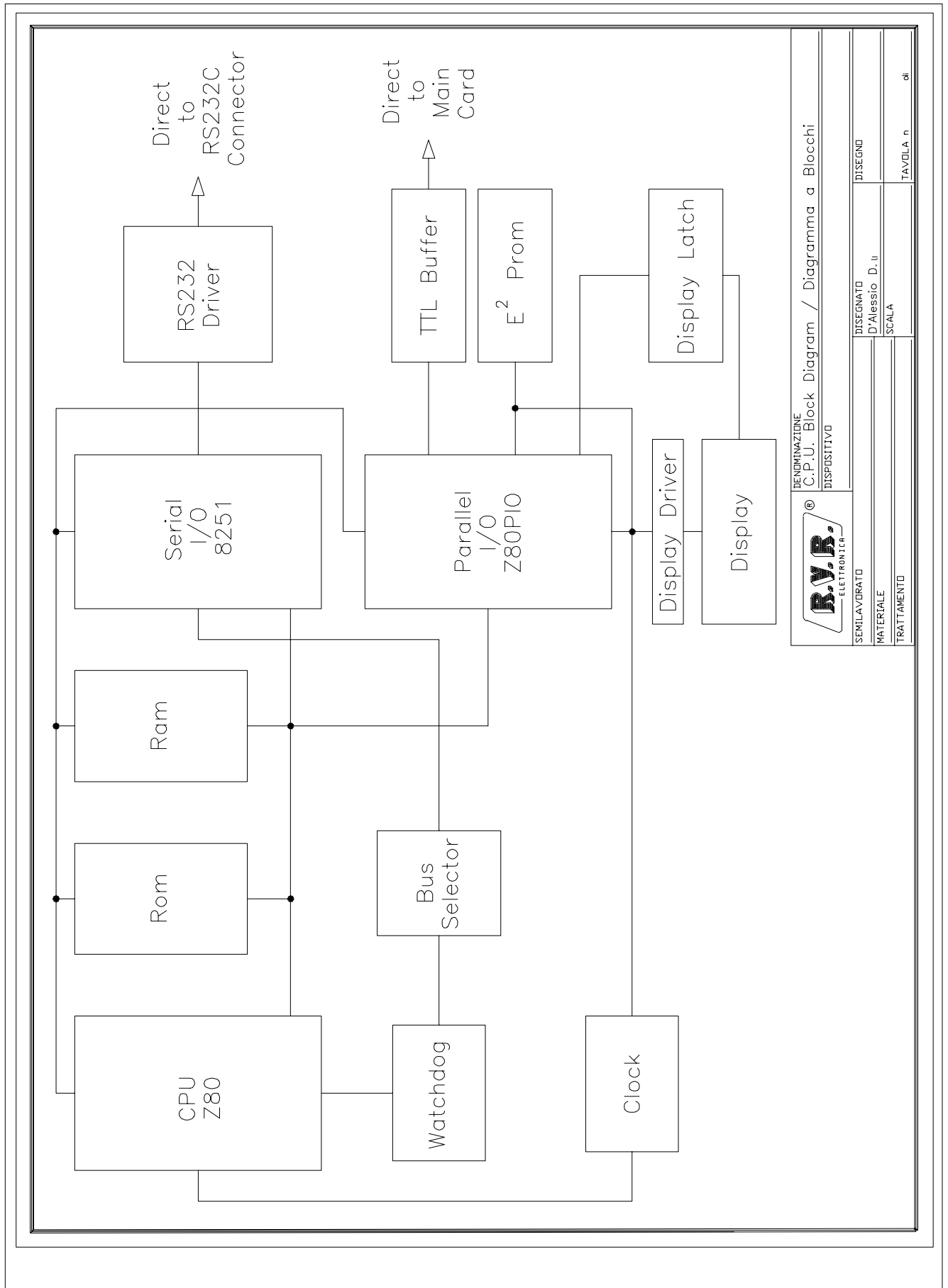

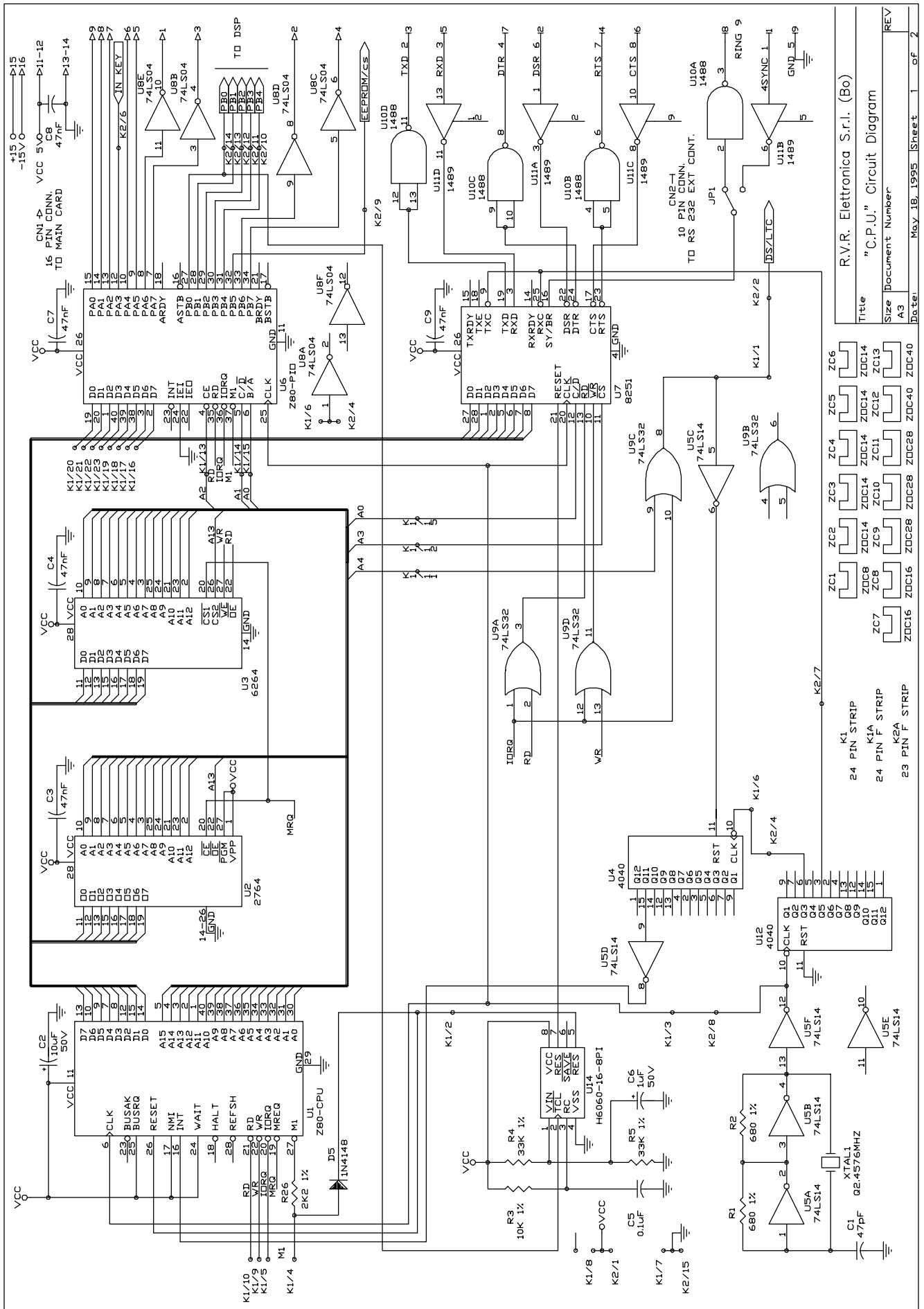

R.V.R. Elettronica S.r.l. (Bo)	
"C.P.U." Circuit Diagram	
Size	Document Number
A3	
Date:	May 18, 1995 Sheet 1 of 2

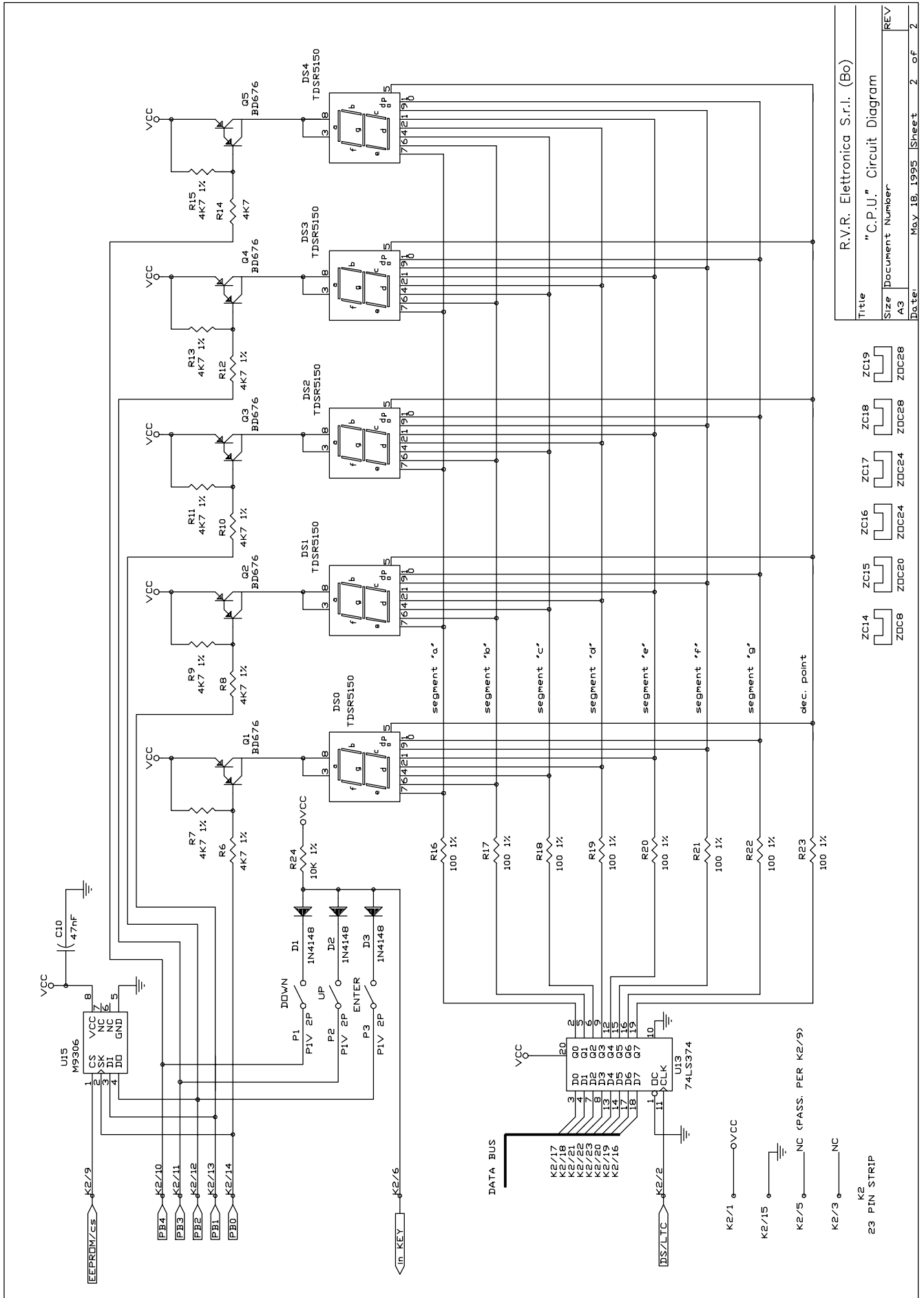

R.V.R. Elettronica S.r.l. (Bo)	
Title	"C.P.U." Circuit Diagram
Size	Document Number
A3	REV
Date	May 18, 1995 Sheet 2 of 2

- ZC14 ZC15 ZC16 ZC17 ZC18 ZC19
- ZC08 ZC20 ZC24 ZC24 ZC28 ZC28

- DATA BUS
- K2/17 K2/18 K2/21 K2/22 K2/23 K2/19 K2/16
- U13 74LS374
- U15 M9306
- Q1-Q5 BD676
- DS0-DS4 TDSRS150
- R16-R23 100 1%
- R24 10K 1%
- R9-R15 4K7 1%
- C10 47nF
- P1, P2, P3 2P
- D1, D2, D3 1N4148
- VCC, GND
- IN KEY
- DOWN, UP, ENTER
- segment 'a' through 'g'
- dec. point
- NC (PASS. PER K2/9)
- NC
- 23 PIN STRIP

Control CPU (CPU)				Bill of Materials	Pag. 1
Item	Quantity	Reference	Part	Description	Part Order Code
1	2	R1,R2	680 1%	RESISTOR 1/4W 1%	RSM1/4FH0680
2	1	R26	2K2 1%	RESISTOR 1/4W 1%	RSC1/4FK02,2
3	1	R3	10K 1%	RESISTOR 1/4W 1%	RSM1/4FK0010
4	2	R4,R5	33K 1%	RESISTOR 1/4W 1%	RSM1/4FK0033
5	1	C1	47pF	CERAMIC CAPACITOR NP0	CKM470BJ600C
6	5	C3,C4,C7, C8,C9	47nF	CERAMIC CAPACITOR	CKM473BK600P
7	1	C5	0.1uF	CERAMIC CAPACITOR	CKM104BK600P
8	1	C6	1uF	ELECTROLYTIC CAPACITOR	CEA105AM630
9	1	C2	10uF	ELECTROLYTIC CAPACITOR	CEA106AM350
10	1	K1	24 P STRIP	STRIP M P 2.54 24 PIN	CNTSTRIPMCS
11	1	K2A	23 PF STRIP	STRIP F P 2.54 23 PIN	CNTSTRIPFCS
12	1	K1A	24 PF STRIP	STRIP F P 2.54 24 PIN	CNTSTRIPFCS
13	1	CN2	10 P CONN	CONN. M 2*5 P 2.54	CNTMCSFC10P
14	1	CN1	16 P CONN	CONN. M 2*8 P 2.54	CNTMCSFC16P
15	1	XTAL1	Q2.4576MHZ	CRYSTAL	QRZ2,45HC18
16	1	D5	1N4148	SILICON DIODE	DIS1N4148
17	1	U10	1488	TTL LEV. SH.TTL RS232	CID1488
18	1	U11	1489	TTL LEV. SH.TTL RS232	CID1489
19	2	U4,U12	4040	CMOS DIVIDER	CID4040
20	1	U8	74LS04	TTL HEX INVERTER	CID74LS04
21	1	U5	74LS14	TTL HEX INVERT. TRIGG.	CID74LS14
22	1	U9	74LS32	TTL QUAD OR	CID74LS32
23	1	U1	Z80-CPU	CPU	CIDZ80CPU
24	1	U6	Z80-PIO	PARALLEL I/O PORT	CIDZ80PIO
25	1	U7	8251	SERIAL I/O PORT	CID8251
26	1	U3	6264	RAM MEMORY 8KBYTE	CID6264
27	1	U2	2764	EPROM MEMORY 8KBYTE	CID2764
28	1	U14	H6060168PI	STANDALONE WATCHDOG	CIDH606016
29	1	ZC1	ZOC8	ZOCC. INTEGRATO 8 PIN	ZIN08

Control CPU (CPU)				Bill of Materials	Pag. 2
Item	Quantity	Reference	Part	Description	Part Order Code
30	5	ZC2,ZC3, ZC4,ZC5,ZC6	ZOC14	ZOCCOLO INTEGR. 14 PIN	ZIN14
31	2	ZC7,ZC8	ZOC16	ZOCCOLO INTEGR. 16 PIN	ZIN16
32	3	ZC9,ZC10, ZC11	ZOC28	ZOCCOLO INTEGR. 28 PIN	ZIN28
33	2	ZC12,ZC13	ZOC40	ZOCCOLO INTEGR. 40 PIN	ZIN40
34	1	JP1	N.C.	NOT CONNECTED	

Control CPU (Display)

Bill of Materials

Pag. 1

Item	Quantity	Reference	Part	Description	Part Order Code
1	8	R16,R17, R18,R19, R20,R21, R22,R23	100 1%	RESISTOR 1/4W 1%	RSM1/4FH0100
2	1	R14	4K7	RESISTOR 1/4W 5%	RSC1/4JK04,7
3	9	R6,R7,R8, R9,R10,R11, R12,R13,R15	4K7 1%	RESISTOR 1/4W 1%	RSM1/4FK04,7
4	1	R24	10K 1%	RESISTOR 1/4W 1%	RSM1/4FK0010
5	1	C10	47nF	CERAMIC CAPACITOR	CKM473BK600P
6	1	K2	23 P STRIP	STRIP M P 2.54 23 PIN	CNTSTRIPMCS
7	3	P1,P2,P3	P1V 2P	PULSANTE 1 VIA 2 POS	PLS1V11M03CS
8	3	D1,D2,D3	1N4148	SILICON DIODE	DIS1N4148
9	5	DS1,DS2, DS3,DS4,DS0	TDSR5150	7 SEGM. DISPLAY	DSPAC14RO
10	5	Q1,Q2,Q3, Q4,Q5	BD676	PNP DARLINGTON	TRNBD676
11	1	U13	74LS374	TTL LATCH	CID74LS374
12	1	U15	M9306	EEPROM 256BIT	CIDM9306
13	1	ZC14	ZOC8	ZOCCOLO INTEGR. 8 PIN	ZIN08
14	1	ZC15	ZOC20	ZOCCOLO INTEGR. 20 PIN	ZIN20
15	2	ZC16,ZC17	ZOC24	ZOCCOLO INTEGR. 24 PIN	ZIN24
16	2	ZC18,ZC19	ZOC28	ZOCCOLO INTEGR. 28 PIN	ZIN28

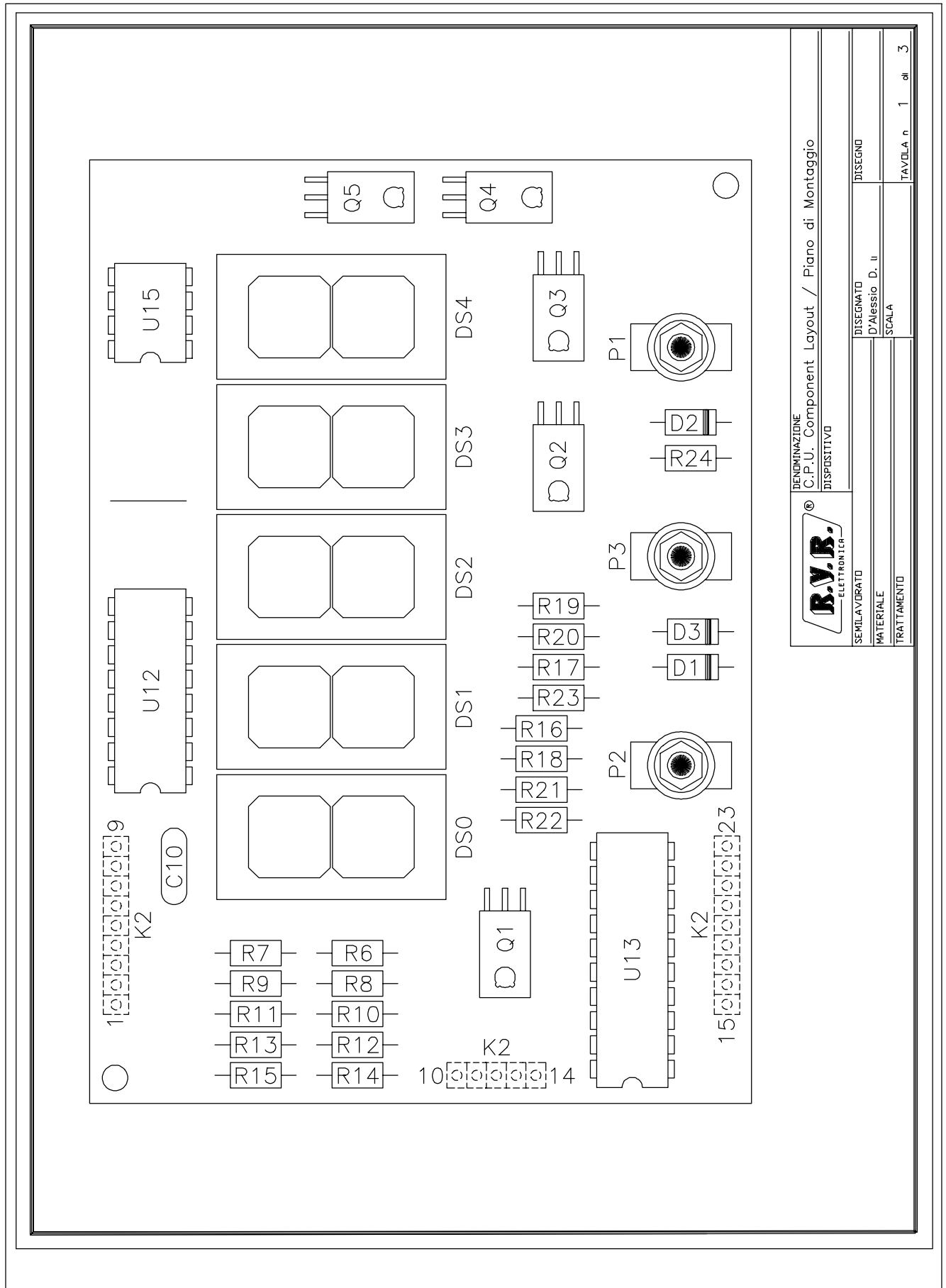

DENOMINAZIONE C.P.U. Component Layout / Piano di Montaggio	
DISPOSITIVO	
SEMILAVORATO	DISEGNATO D'Alessio D. U.
MATERIALE	SCALA
TRATTAMENTO	TAVOLA n. 1 di 3

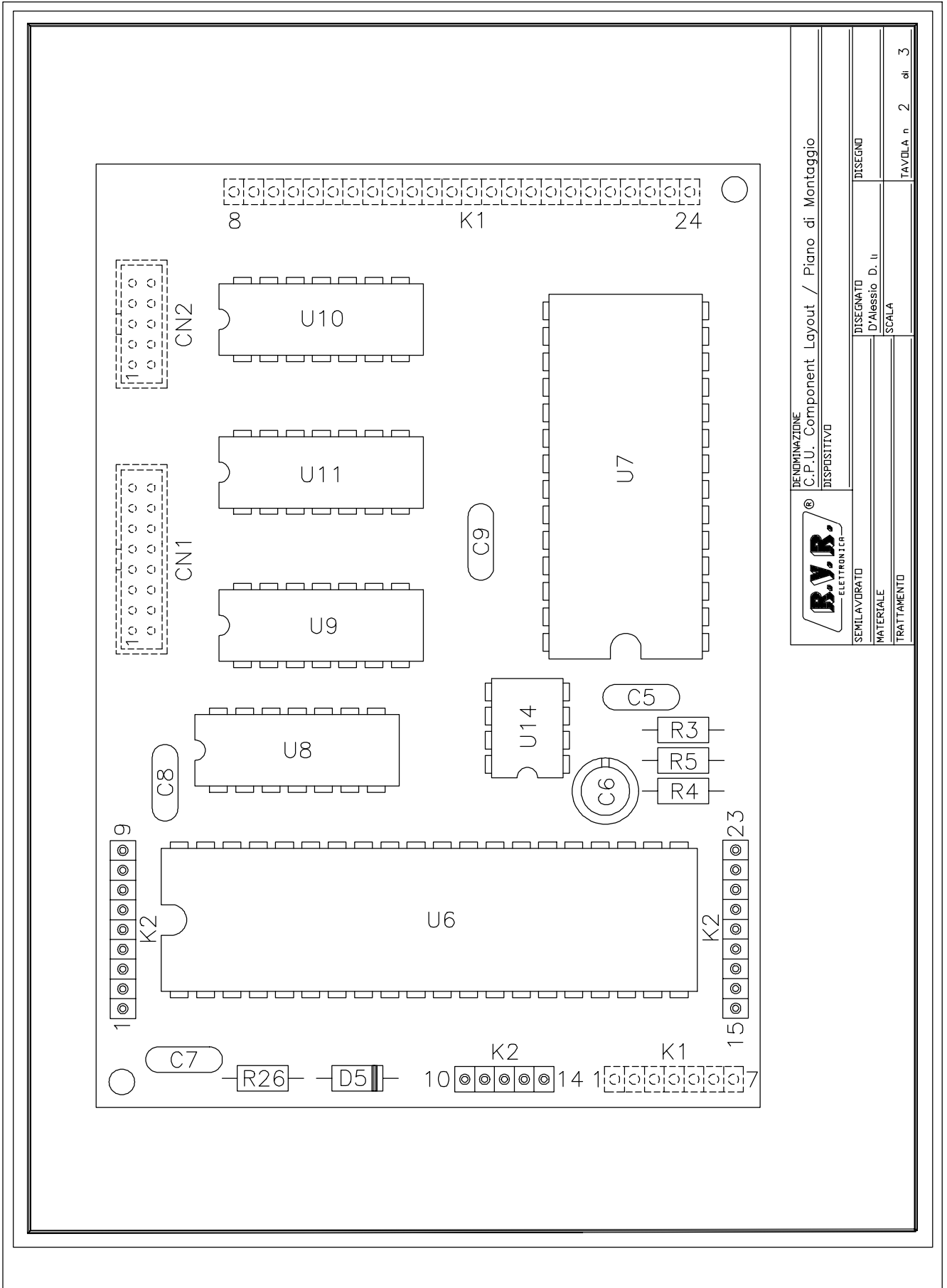

DENOMINAZIONE C.P.U. Component Layout / Piano di Montaggio	
DISPOSITIVO	
SEMILAVORATO	DISEGNATO D'Alessio D. U.
MATERIALE	SCALA
TRATTAMENTO	TAVOLA n. 2 di 3

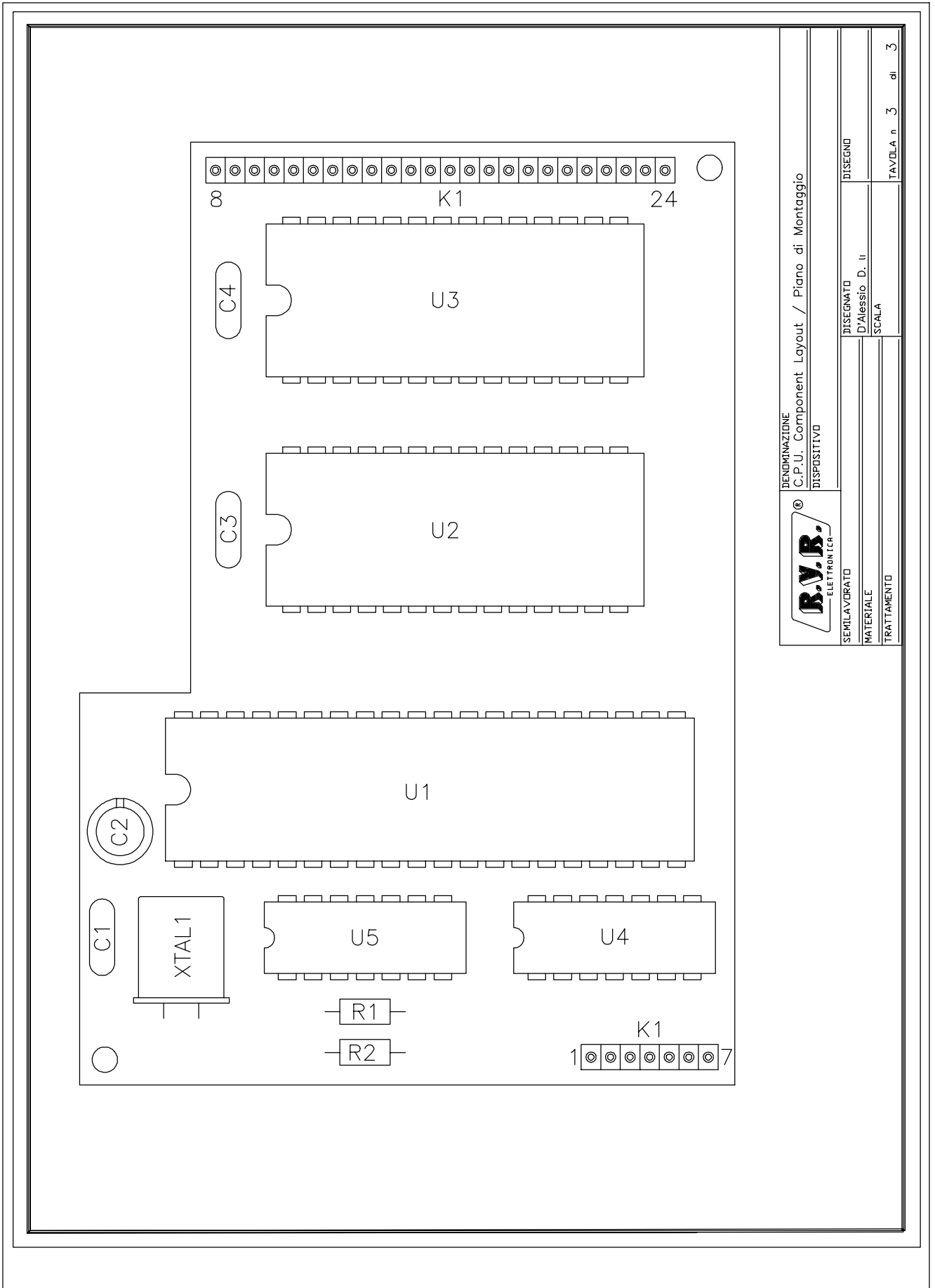

MODMETER CARD

- A) Circuit Diagram
- B) Bill of Materials
- C) Layout

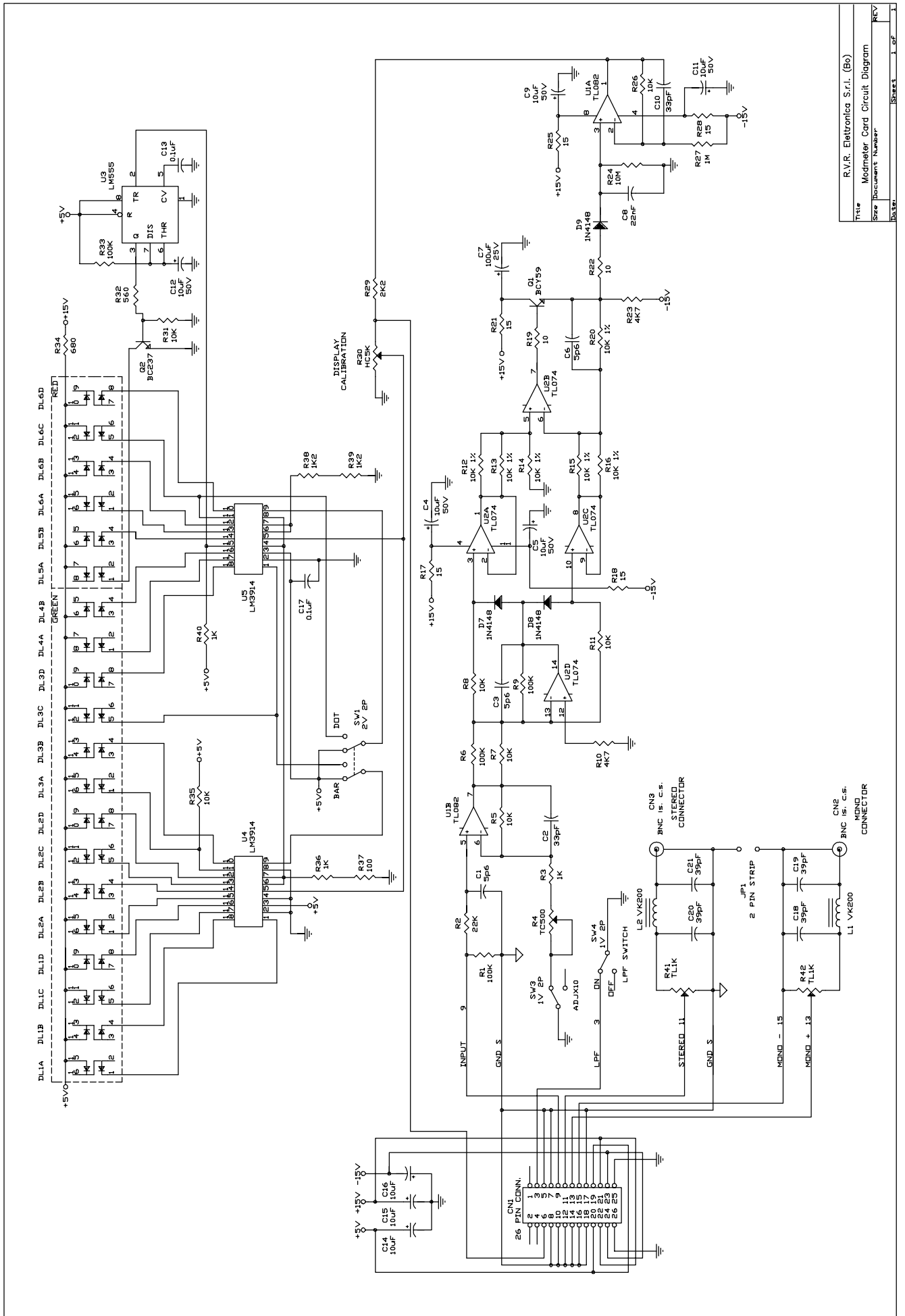

Title	R.V.R. Elettronica S.r.l. (Bo)
See Placement Number	Modem Card Circuit Diagram
REV	1

Modulation Meter				Bill of Materials	Pag. 1
Item	Quantity	Reference	Part	Description	Part Order Code
1	2	R19,R22	10	RESISTOR 1/4W 5%	RSC1/4JH0010
2	5	R17,R18, R21,R25,R28	15	RESISTOR 1/4W 5%	RSC1/4JH0015
3	1	R37	100	RESISTOR 1/4W 5%	RSC1/4JH0100
4	1	R32	560	RESISTOR 1/4W 5%	RSC1/4JH0560
5	1	R34	680	RESISTOR 1/4W 5%	RSC1/4JH0680
6	3	R3,R36,R40	1K	RESISTOR 1/4W 5%	RSC1/4JK0001
7	2	R38,R39	1K2	RESISTOR 1/4W 5%	RSC1/4JK01,2
8	1	R29	2K2	RESISTOR 1/4W 5%	RSC1/4JK02,2
9	2	R10,R23	4K7	RESISTOR 1/4W 5%	RSC1/4JK04,7
10	6	R12,R13, R14,R15, R16,R20	10K 1%	RESISTOR 1/4W 1%	RSM1/4FK0010
11	7	R5,R7,R8, R11,R26, R31,R35	10K	RESISTOR 1/4W 5%	RSC1/4JK0010
12	1	R2	22K	RESISTOR 1/4W 5%	RSC1/4JK0022
13	4	R1,R6, R9,R33	100K	RESISTOR 1/4W 5%	RSC1/4JK0100
14	1	R27	1M	RESISTOR 1/4W 5%	RSC1/4JM0001
15	1	R24	10M	RESISTOR 1/4W 5%	RSC1/4JM0010
16	1	R4	TC500	TRIM.REG.VERT. CERMET	RVTCERVH0500
17	2	R41,R42	TL1K	TRIM.REG.VERT. 15mm	RVTD15VK0001
18	1	R30	HC5K	TRIM.REG.ORIZZ. CERMET	RVTCEROK0005
19	1	ALB1	ALB	ALBERINO TRIMMER 15mm	ALBERINOXRVT
20	3	C1,C3,C6	5p6	CERAMIC CAPACITOR NP0	CKM5,6BJ600C
21	2	C2,C10	33pF	CERAMIC CAPACITOR NP0	CKM330BJ600C
22	4	C18,C19, C20,C21	39pF	CERAMIC CAPACITOR NP0	CKM390BJ600C
23	1	C8	22nF	CERAMIC CAPACITOR	CKM223BK600P
24	2	C13,C17	0.1uF	CERAMIC CAPACITOR	CKM104BK600P
25	8	C4,C5,C9, C11,C12, C14,C15,C16	10uF	ELECTROLYTIC CAPACITOR	CEA106AM350

Modulation Meter				Bill of Materials	Pag. 2
Item	Quantity	Reference	Part	Description	Part Order Code
26	1	C7	100uF	ELECTROLYTIC CAPACITOR	CEA107BM350
27	2	L1,L2	VK200	RF CHOKE	IMPVK200
28	1	JP1	2 P STRIP	STRIP M P 2.54 2 PIN	CNTSTRIPMCS
29	1	CN1	26 P CONN	CONN. M 2*13 P 2.54	CNTMCSFC26P
30	2	CN2,CN3	BNC IS.C.S.	CONN. BNC A STAMP. IS.	CNTBNCFCISIS
31	2	SW3,SW4	1V 2P	DEVIATORE 1 VIA 2 POS	DEV1V1103CS
32	1	SW1	2V 2P	DEVIATORE 2 VIE 2 POS	DEV2V1103CS
33	3	D7,D8,D9	1N4148	SILICON DIODE	DIS1N4148
34	1	DL5	HLMP2600	2 RED LED DIODE	LEDHLMP2600
35	1	DL6	HLMP2620	4 RED LED DIODE	LEDHLMP2620
36	1	DL4	HLMP2800	2 GREEN LED DIODE	LEDHLMP2800
37	3	DL1,DL2, DL3	HLMP2820	4 GREEN LED DIODE	LEDHLMP2820
38	1	Q2	BC237	NPN TRANSISTOR	TRNBC237
39	1	Q1	BCY59	NPN TRANSISTOR	TRNBCY59
40	1	U1	TL082	DOUBLE OP. AMP.	CILTL082
41	1	U2	TL074	QUAD OP. AMP.	CILTL074
42	1	U3	LM555	TIMER	CIL555
43	2	U4,U5	LM3914	BAR DOT LED DRIVER	CILLM3914

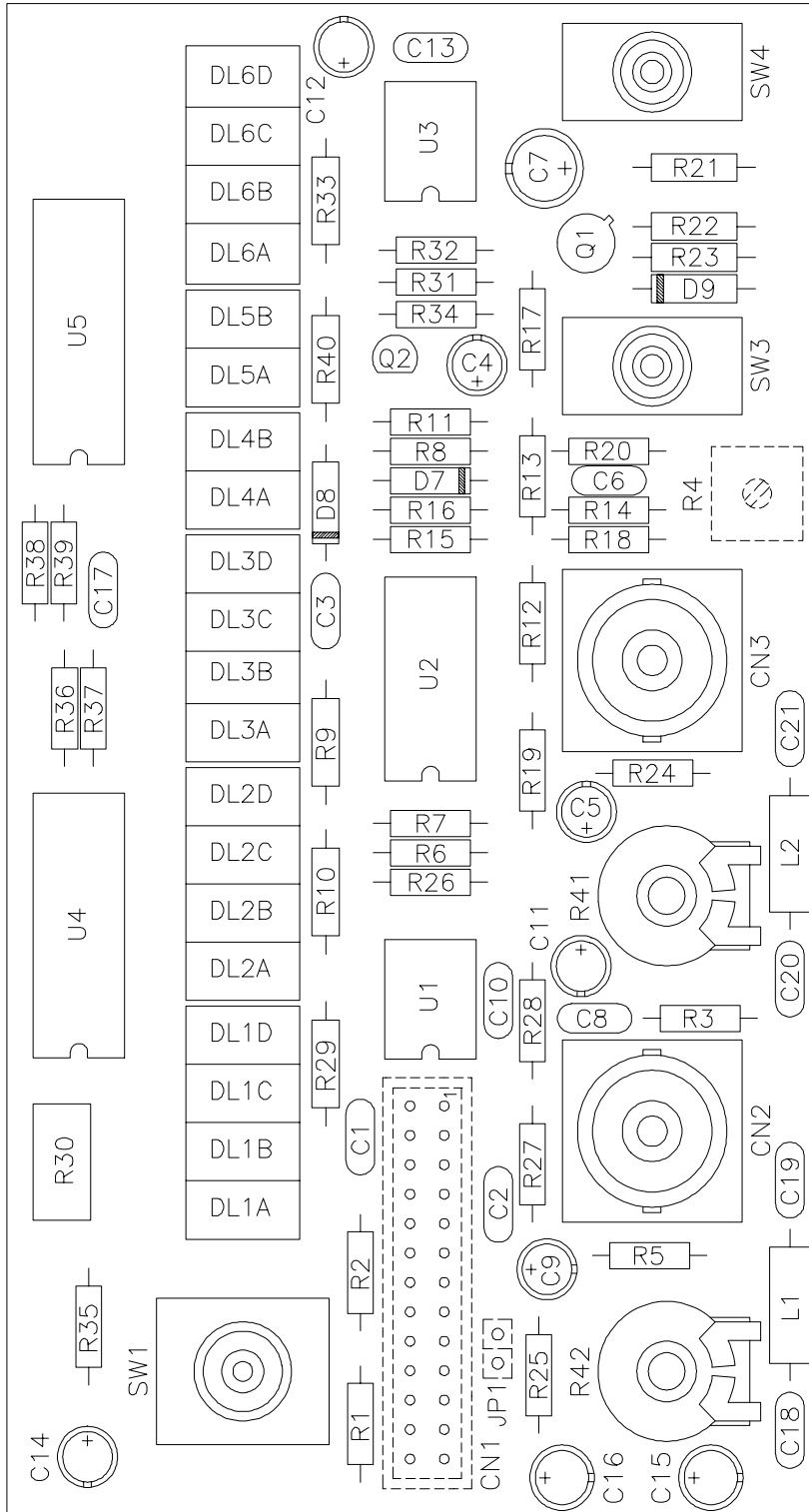

	DENOMINAZIONE Modmeter Card Component Layout / Piano di Montaggio	
	DISPOSITIVO PTRL-NV/S3 (Aural STL Stereo Transmitter)	
SEMILAVORATO	DISEGNATO D'Alessio D. II	DISEGNO
MATERIALE	SCALA	TAVOLA n. di
TRATTAMENTO		

ANAMETER CARD

- A) Anameter Card 1 Circuit Diagram
- B) Anameter Card 1 Bill of Materials
- C) Anameter Card 1 Layout
- D) Anameter Card 2 Circuit Diagram
- E) Anameter Card 2 Bill of Materials
- F) Anameter Card 2 Layout

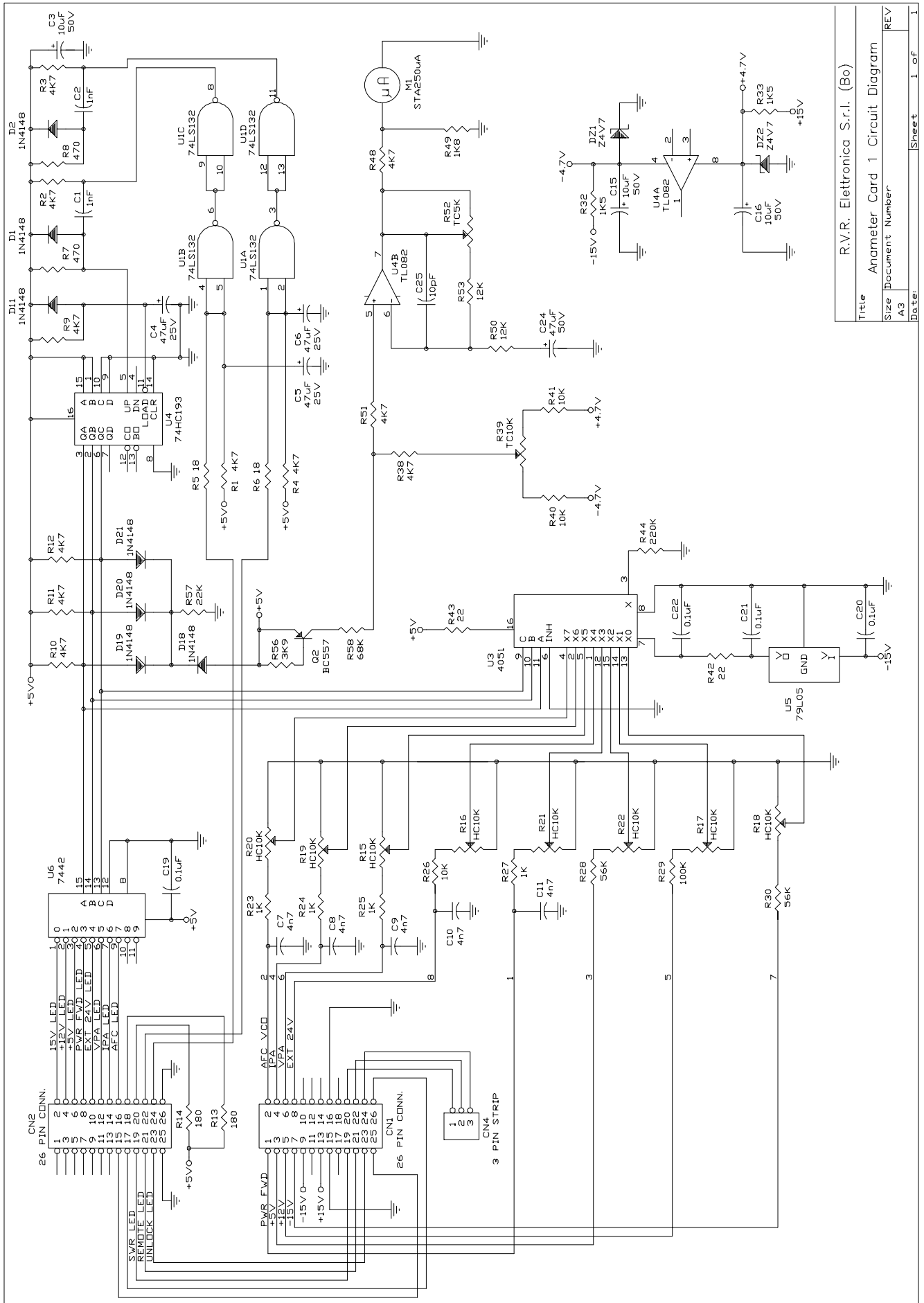

Title		R.V.R. Elettronica S.r.l. (Bo)	
Size		Anameter Card 1 Circuit Diagram	
Doc. Number	REV	Date:	Sheet 1 of 1

Anameter Card 1				Bill of Materials	Pag. 1
Item	Quantity	Reference	Part	Description	Part Order Code
1	2	R5, R6	18	RESISTOR 1/4W 5%	RSC1/4JH0018
2	2	R42, R43	22	RESISTOR 1/4W 5%	RSC1/4JH0022
3	2	R13, R14	180	RESISTOR 1/4W 5%	RSC1/4JH0180
4	2	R7, R8	470	RESISTOR 1/4W 5%	RSC1/4JH0470
5	4	R23, R24, R25, R27	1K	RESISTOR 1/4W 5%	RSC1/4JK0001
6	2	R32, R33	1K5	RESISTOR 1/4W 5%	RSC1/4JK01,5
7	1	R49	1K8	RESISTOR 1/4W 5%	RSC1/4JK01,8
8	1	R56	3K9	RESISTOR 1/4W 5%	RSC1/4JK03,9
9	11	R1, R2, R3, R4, R9, R10, R11, R12, R38, R48, R51	4K7	RESISTOR 1/4W 5%	RSC1/4JK04,7
10	3	R26, R40, R41	10K	RESISTOR 1/4W 5%	RSC1/4JK0010
11	2	R50, R53	12K	RESISTOR 1/4W 5%	RSC1/4JK0012
12	1	R57	22K	RESISTOR 1/4W 5%	RSC1/4JK0022
13	2	R28, R30	56K	RESISTOR 1/4W 5%	RSC1/4JK0056
14	1	R58	68K	RESISTOR 1/4W 5%	RSC1/4JK0068
15	1	R29	100K	RESISTOR 1/4W 5%	RSC1/4JK0100
16	1	R44	220K	RESISTOR 1/4W 5%	RSC1/4JK0220
17	1	R52	TC5K	TRIM.REG.VERT. CERMET	RVTCERVK0005
18	1	R39	TC10K	TRIM.REG.VERT. CERMET	RVTCERVK0010
19	8	R15, R16, R17, R18, R19, R20, R21, R22	HC10K	TRIM.REG.ORIZZ. CERMET	RVTCEROK0010
20	1	C25	10pF	CERAMIC CAPACITOR NP0	CKM100BJ600C
21	2	C1, C2	1nF	CERAMIC CAPACITOR	CKM102BK600P
22	5	C7, C8, C9, C10, C11	4n7	CERAMIC CAPACITOR	CKM472BK600P
23	4	C19, C20, C21, C22	0.1uF	CERAMIC CAPACITOR	CKM104BK600P
24	3	C3, C15, C16	10uF	ELECTROLYTIC CAPACITOR	CEA106AM350

Anameter Card 1			Bill of Materials		Pag. 2
Item	Quantity	Reference	Part	Description	Part Order Code
25	4	C4,C5, C6,C24	47uF	ELECTROLYTIC CAPACITOR	CEA476BM630
26	1	M1	STA250UA	STRUMENTO 250uA	SMABM55RQ251
27	1	CN4	3 P STRIP	STRIP M P 2.54 3 PIN	CNTSTRIPMCS
28	2	CN1,CN2	26 P CONN	CONN. M 2*13 P 2.54	CNTMCSFC26P
29	7	D1,D2,D11, D18,D19, D20,D21	1N4148	SILICON DIODE	DIS1N4148
30	2	DZ1,DZ2	Z4V7	ZENER DIODE 4.7V 0.4W	DIZ4V70W4
31	1	U5	79L05	NEG. STABILIZER 100mA	CIL79L05
32	1	Q2	BC557	PNP TRANSISTOR	TRNBC557
33	1	U4	TL082	DOUBLE OP. AMP.	CILTL082
34	1	U3	4051	ANALOG MULTIPLEXER	CID4051
35	1	U6	7442	TTL BCD DECODER	CID7442
36	1	U1	74LS132	TTL QUAD NAND TRIGGER	CID74LS132
37	1	U4	74HC193	CMOS BIN COUNTER	CID74HC193s

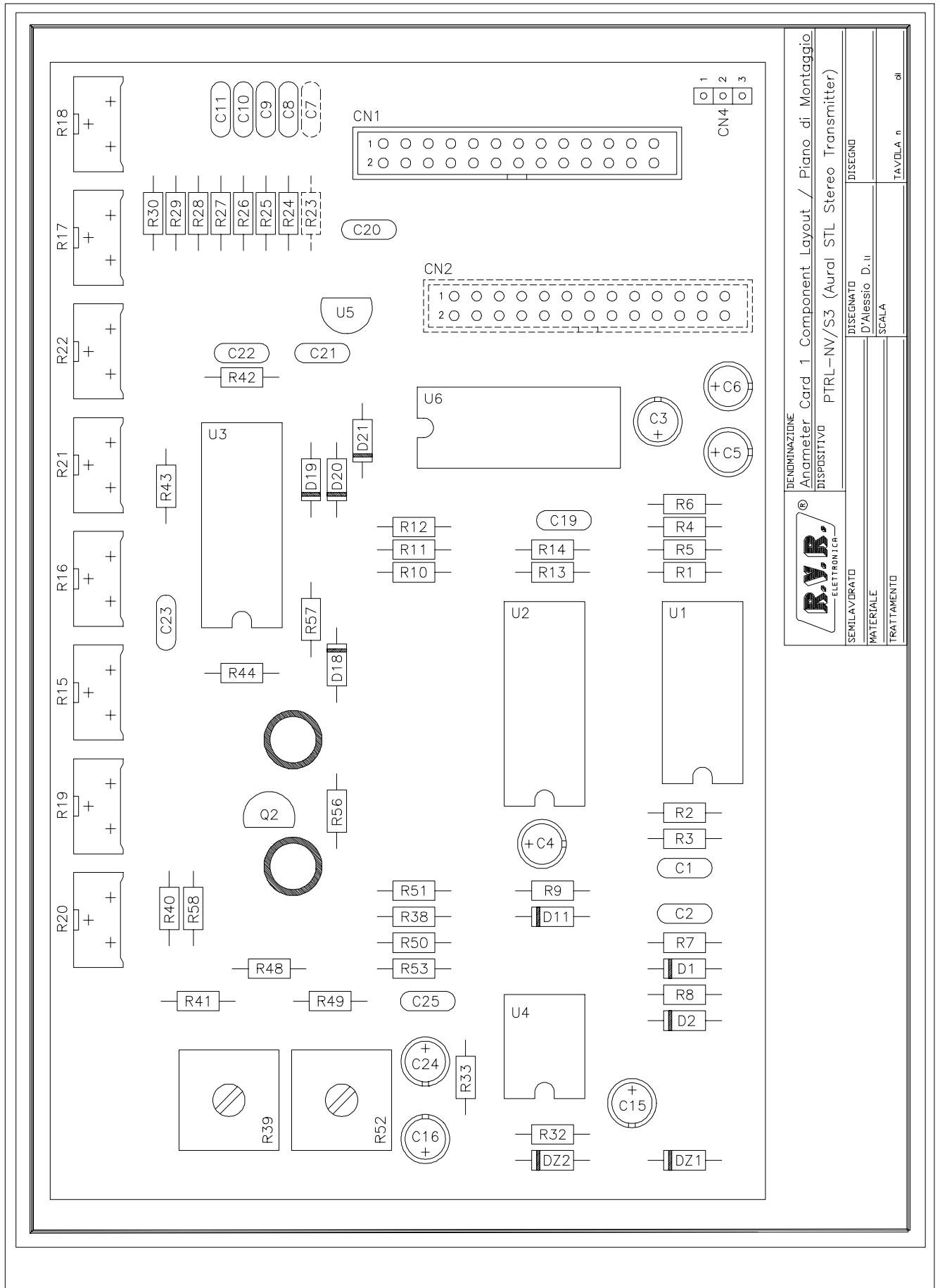

DENOMINAZIONE Anameter Card 1 Component Layout / Piano di Montaggio		DISEGNO D'Alessio D. II	
DISPOSITIVO PTRL-NV/S3 (Aural STL Stereo Transmitter)		SCALA	
SEMILAVORATO		TAVOLA n. di	
MATERIALE		TRATTAMENTO	

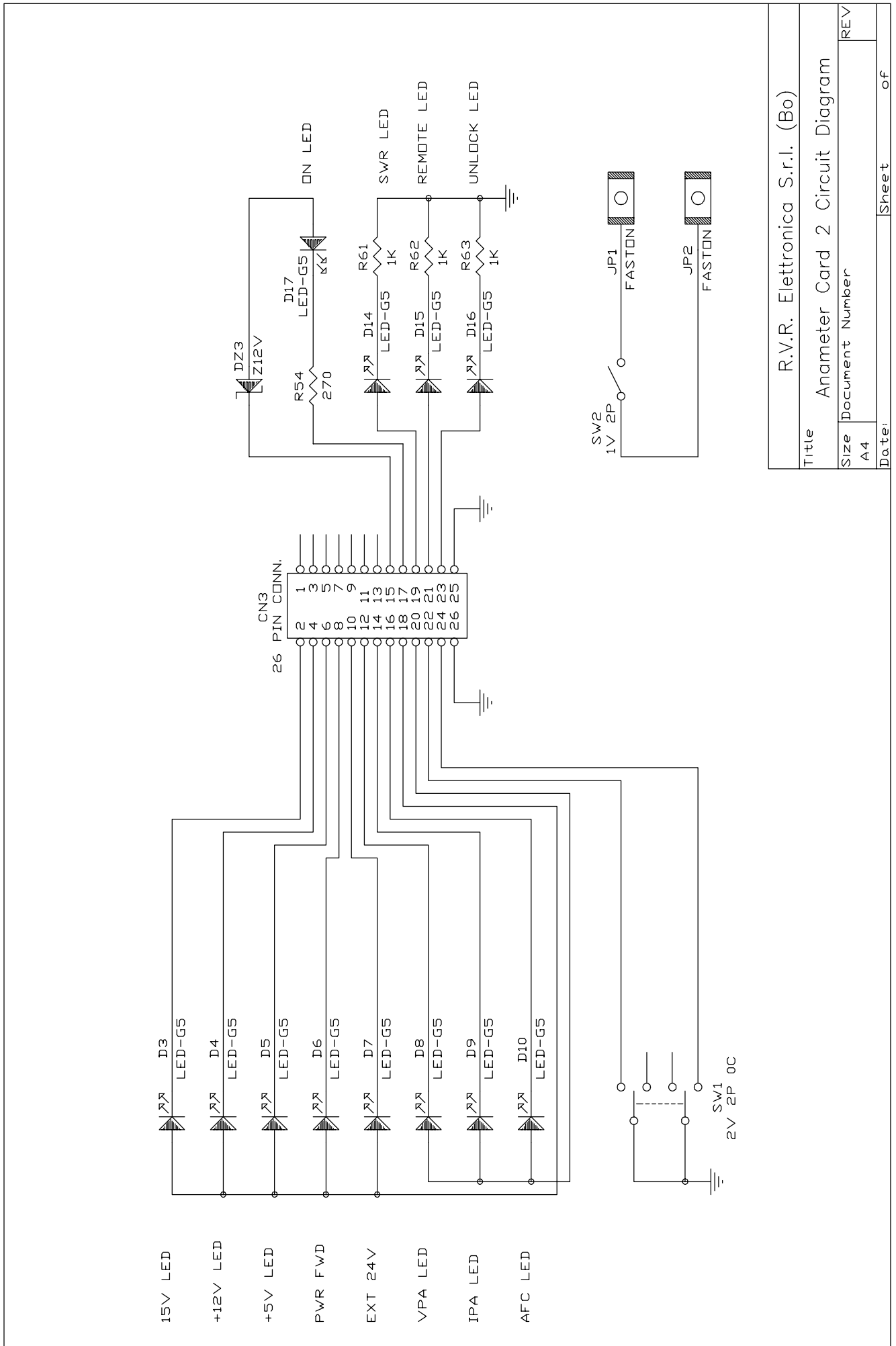

Title		R.V.R. Elettronica S.r.l. (Bo)	
Document Number		Anameter Card 2 Circuit Diagram	
Size	Document Number	REV	REV
A4			
Date:		Sheet	of

Anameter Card 2

Bill of Materials

Pag. 1

Item	Quantity	Reference	Part	Description	Part Order Code
1	1	R54	270	RESISTOR 1/4W 5%	RSC1/4JH0270
2	3	R61,R62, R63	1K	RESISTOR 1/4W 5%	RSC1/4JK0001
3	2	JP1,JP2	FASTON	CONN. FASTON M CIRC.ST.	CNTFSTMCSGR
4	1	CN3	26 P CONN	CONN. M 2*13 P 2.54	CNTMCSFC26P
5	1	SW2	1V 2P	DEVIATORE 1V 2P	DEV1V1103CS
6	1	SW1	2V 2P 0C	DEVIATORE 2V 2P 0C	DEV2V1M01M03
7	12	D3,D4,D5, D6,D7,D8, D9,D10,D14, D15,D16,D17	LED-G5	GREEN LED DIODE	LEDVE05
8	1	DZ3	Z12V	ZENER DIODE 12V 0.4W	DIZ12V0W4

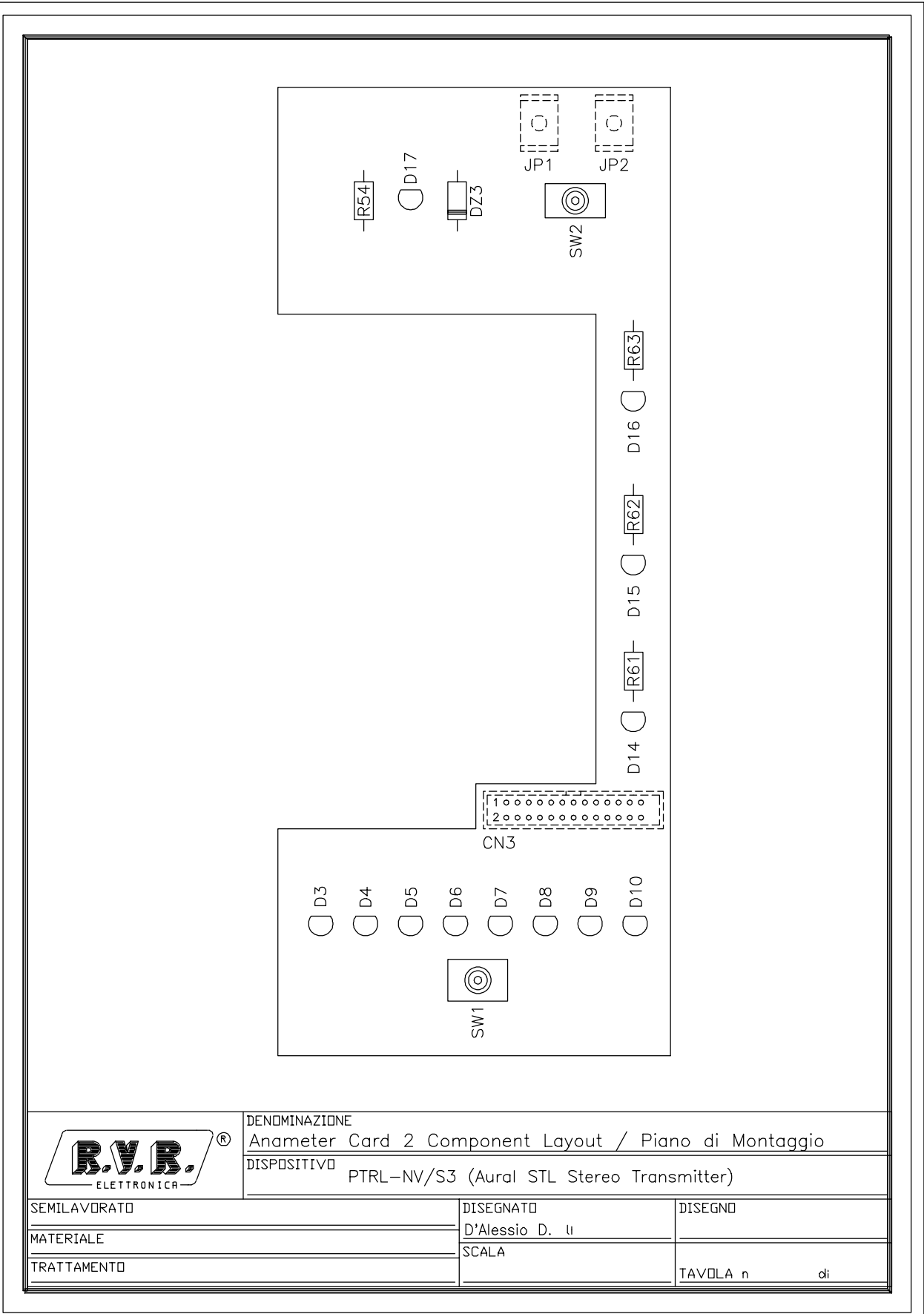

	DENOMINAZIONE	
	Anameter Card 2 Component Layout / Piano di Montaggio	
	DISPOSITIVO	
	PTRL-NV/S3 (Aural STL Stereo Transmitter)	
SEMILAVORATO	DISEGNATO	DISEGNO
MATERIALE	D'Alessio D. li	
TRATTAMENTO	SCALA	TAVOLA n di

POWER SUPPLY

- A) Power Supply General Circuit Diagram
(without Inverter Card)
- B) Power Supply General Circuit Diagram
(with Inverter Card)
- C) Power Supply Card 1 Circuit Diagram
- D) Power Supply Card 1 Bill of Materials
- E) Power Supply Card 1 Component Layout
- F) Power Supply Card 2 Circuit Diagram
- G) Power Supply Card 2 Bill of Materials
- H) Power Supply Card 2 Component Layout

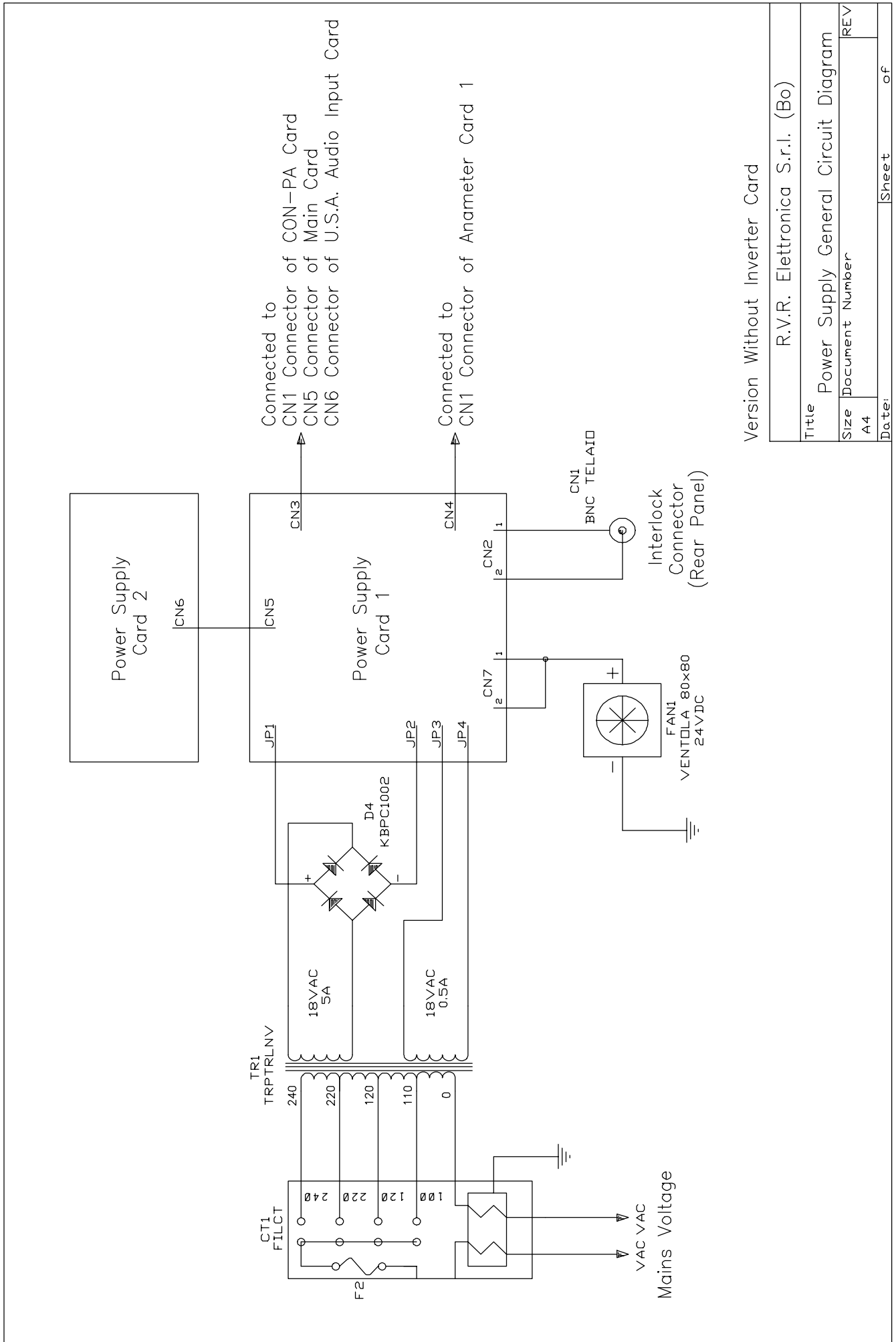

Version Without Inverter Card

Title		R.V.R. Elettronica S.r.l. (Bo)
Size		Power Supply General Circuit Diagram
Document Number		REV
Date:		Sheet of

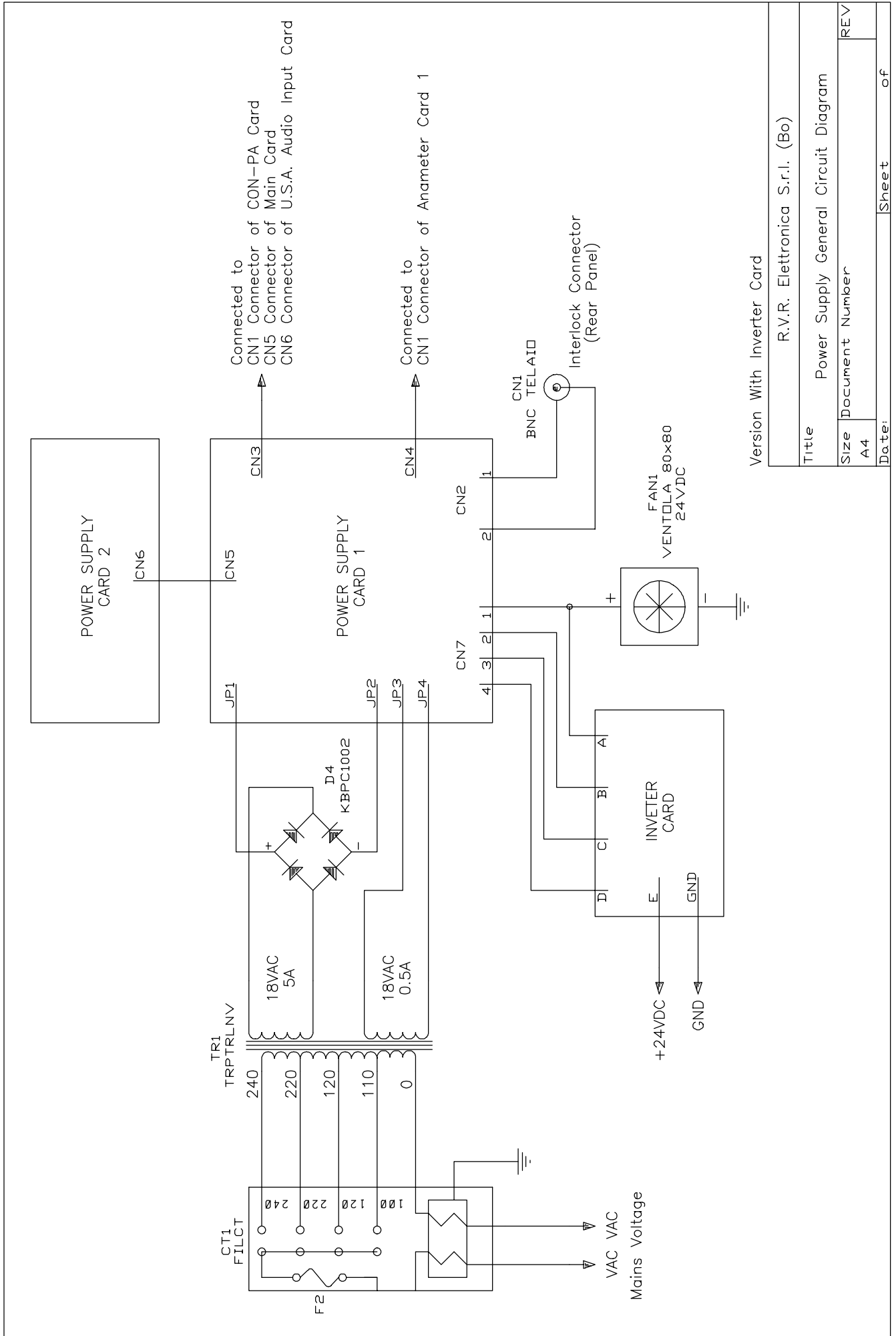

Version With Inverter Card

R.V.R. Elettronica S.r.l. (Bo)	
Title Power Supply General Circuit Diagram	
Size A4	Document Number REV
Date:	Sheet of

Power Supply Card 1				Bill of Materials	Pag. 1
Item	Quantity	Reference	Part	Description	Part Order Code
1	2	R34, R57	0.22 Ω	RESISTOR 5W	RAF005JH0, 22
2	4	R32, R40, R50, R55	10	RESISTOR 1/4W 5%	RSC1/4JH0010
3	1	R31	220	RESISTOR 1/4W 5%	RSC1/4JH0220
4	1	R28	220*	RESISTOR 1/2W 5%	RSC1/2JH0220
5	1	R27	330	RESISTOR 1/4W 5%	RSC1/4JH0330
6	4	R4, R9, R33, R46	1K	RESISTOR 1/4W 5%	RSC1/4JK0001
7	1	R25	1K8	RESISTOR 1/4W 5%	RSC1/4JK01, 8
8	4	R36, R37, R45, R56	2K2	RESISTOR 1/4W 5%	RSC1/4JK02, 2
9	6	R16, R17, R19, R20, R24, R35	4K7	RESISTOR 1/4W 5%	RSC1/4JK04, 7
10	3	R13, R26, R47	6K8	RESISTOR 1/4W 5%	RSC1/4JK06, 8
11	2	R5, R10	8K2	RESISTOR 1/4W 5%	RSC1/4JK08, 2
12	10	R2, R7, R15, R29, R30, R38, R41, R42, R48, R49	10K	RESISTOR 1/4W 5%	RSC1/4JK0010
13	2	R1, R6	12K	RESISTOR 1/4W 5%	RSC1/4JK0012
14	2	R11, R12	27K	RESISTOR 1/4W 5%	RSC1/4JK0027
15	3	R21, R39, R43	33K	RESISTOR 1/4W 5%	RSC1/4JK0033
16	1	R22	68K	RESISTOR 1/4W 5%	RSC1/4JK0068
17	2	R18, R44	100K	RESISTOR 1/4W 5%	RSC1/4JK0100
18	1	R14	1M	RESISTOR 1/4W 5%	RSC1/4JM0001
19	4	R51, R52, R53, R54	2M2 1%	RESISTOR 1/4W 1%	RSM1/4FM02, 2
20	2	R3, R8	HC5K	TRIM.REG.ORIZZ. CERMET	RVTCEROK0005
21	1	C24	47pF	CERAMIC CAPACITOR NP0	CKM470BJ600C
22	7	C16, C19, C23, C25, C29, C35, C43	470pF	CERAMIC CAPACITOR	CKM471BK600P
23	1	C30	1nF	CERAMIC CAPACITOR	CKM102BK600P

Power Supply Card 1				Bill of Materials	Pag. 2
Item	Quantity	Reference	Part	Description	Part Order Code
24	1	C22	4n7	CERAMIC CAPACITOR	CKM472BK600P
25	6	C27,C31, C33,C37, C38,C39	10nF	CERAMIC CAPACITOR	CKM103BK600P
26	6	C15,C18, C40,C41, C48,C50	47nF	CERAMIC CAPACITOR	CKM473BK600P
27	7	C10,C17, C20,C21, C47,C51,C52	0.1uF	CERAMIC CAPACITOR	CKM104BK600P
28	4	C26,C36, C44,C53	10uF	ELECTROLYTIC CAPACITOR	CEA106AM350
29	2	C28,C34	33uF	ELECTROLYTIC CAPACITOR	CEA336BM350
30	2	C9,C13	47uF	ELECTROLYTIC CAPACITOR	CEA476BM630
31	3	C14,C32, C49	100uF	ELECTROLYTIC CAPACITOR	CEA107BM350
32	1	C8	2200uF	ELECTROLYTIC CAPACITOR	CEA228CM350
33	1	C5	22000uF	ELECTROLYTIC CAPACITOR	CEA229PM630
34	3	L1,L2,L3	VK200	RF CHOKE	IMPVK200
35	1	F1	F4A	FAST FUSIBLE	FUS5X20RP4
36	3	CN2,JP8, JP9	2 P STRIP	STRIP M P 2.54 2 PIN	CNTSTRIPMCS
37	1	JP7	3 P STRIP	STRIP M P 2.54 3 PIN	CNTSTRIPMCS
38	4	JP1,JP2, JP3,JP4	FASTON	CONN. FASTON M CIRC.ST.	CNTFSTMCSGR
39	1	CN7	MORS.CS 4	MORSETTIERA C.S. 4CON.	MORSKB04PPO
40	2	CN4,CN5	26 P CONN	CONN. M 2*13 P 2.54	CNTMCSFC26P
41	1	CN3	34 P CONN	CONN. M 2*17 P 2.54	CNTMCSFC34P
42	5	D17,D18, D19,D20,D21	1N4148	SILICON DIODE	DIS1N4148
43	11	D3,D5,D6, D7,D8,D9, D10,D11, D12,D15,D16	1N4003	SILICON DIODE 200V	DIS1N4003
44	1	DZ1	Z18V	ZENER DIODE 18V 0.4W	DIZ18V0W4
45	1	U2	7805	POS. STABILIZER 1A	CIL7805P

Power Supply Card 1

Bill of Materials

Pag. 3

Item	Quantity	Reference	Part	Description	Part Order Code
46	1	U4	7915	NEG. STABILIZER 1A	CIL7915P
47	1	U8	LM723	VAR. STABILIZER 100mA	CILLM723
48	2	Q2,Q3	BC237	NPN TRANSISTOR	TRNBC237
49	3	U6,U7,U9	LM358N	DOUBLE OP. AMP.	CILLM358N

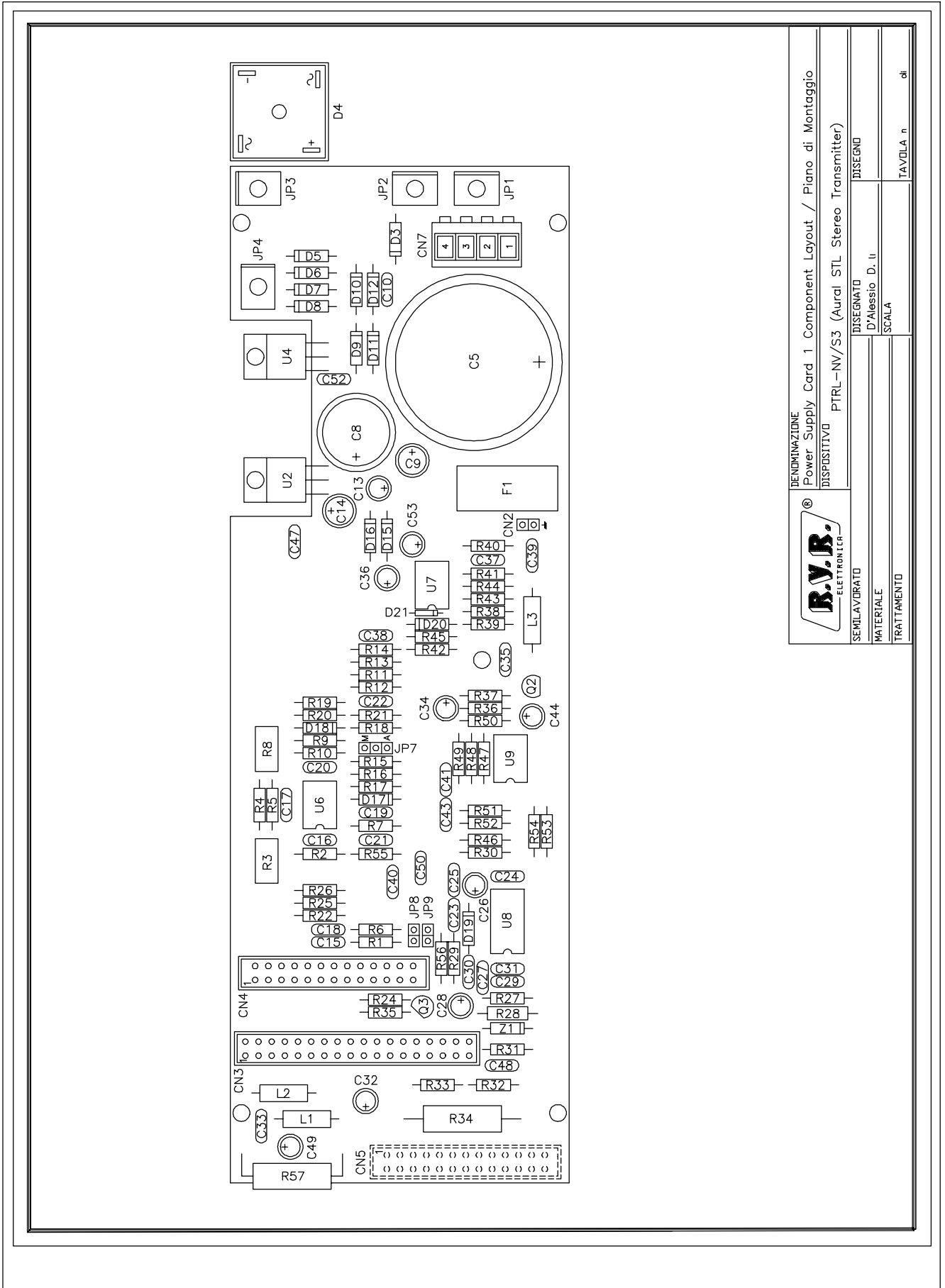

B.V.V.B. ELETTRONICA S.p.A.	
DENOMINAZIONE Power Supply Card 1 Component Layout / Piano di Montaggio	
DISPOSITIVO PTRL-NV/S3 (Aural STL Stereo Transmitter)	
SEMILAVORATO	DISEGNATO D'Alessio D. U.
MATERIALE	SCALA
TRATTAMENTO	TAVOLA n. di

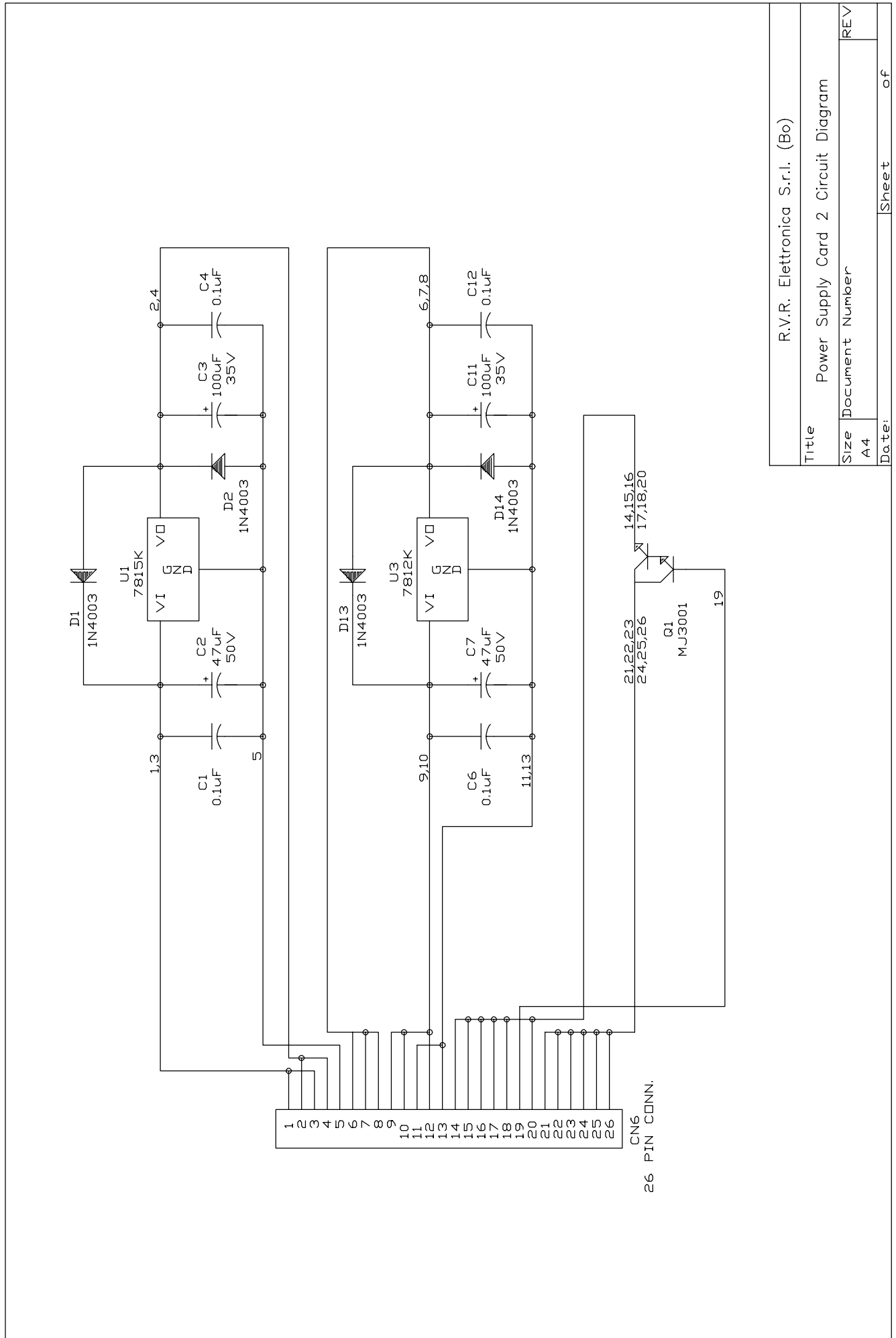

Title		R.V.R. Elettronica S.r.l. (Bo)	
Size		Power Supply Card 2 Circuit Diagram	
Document Number		REV	
Date:		Sheet	of

Power Supply Card 2

Bill of Materials

Pag. 1

Item	Quantity	Reference	Part	Description	Part Order Code
1	4	C1,C4, C6,C12	0.1uF	CERAMIC CAPACITOR	CKM104BK600P
2	2	C2,C7	47uF	ELECTROLYTIC CAPACITOR	CEA476BM630
3	2	C3,C11	100uF	ELECTROLYTIC CAPACITOR	CEA107BM350
4	1	CN6	26 P CONN	CONN. M 2*13 P 2.54	CNTMCSFC26P
5	4	D1,D2, D13,D14	1N4003	SILICON DIODE 200V	DIS1N4003
6	1	U3	7812K	POS. STABILIZER 1.5A	CIL7812K
7	1	U1	7815K	POS. STABILIZER 1.5A	CIL7815K
8	1	Q1	MJ3001	POWER TRANSISTOR	TRNMJ3001

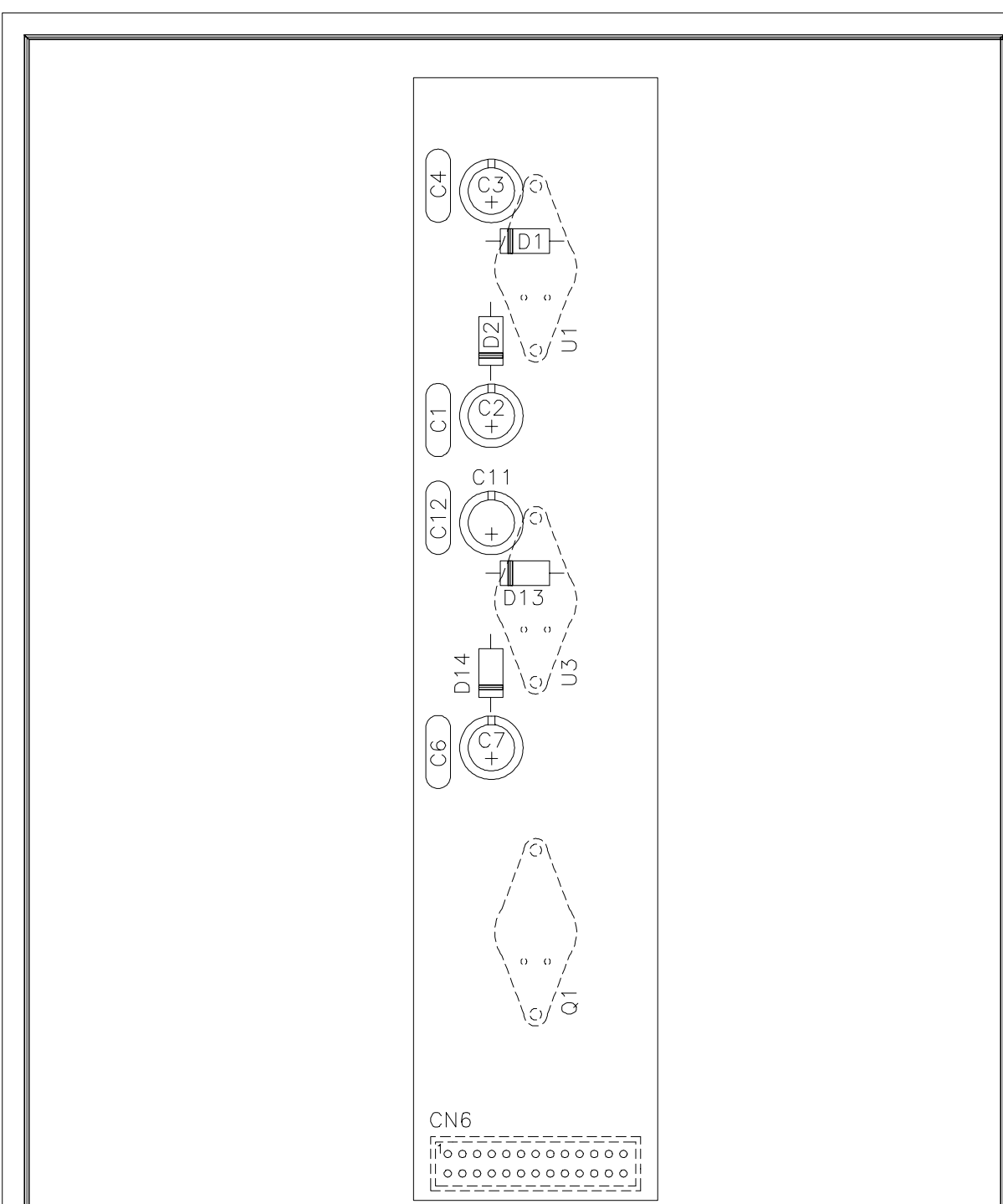

	DENOMINAZIONE Power Supply Card 2 Component Layout / Piano di Montaggio	
	DISPOSITIVO PTRL-NV/S3 (Aural STL Stereo Transmitter)	
SEMILAVORATO	DISEGNATO D'Alessio D. U.	DISEGNO
MATERIALE	SCALA	
TRATTAMENTO		TAVOLA n di

2W R.F. POWER AMPLIFIER

- A) Circuit Diagram
- B) Bill of Materials
- C) Layout

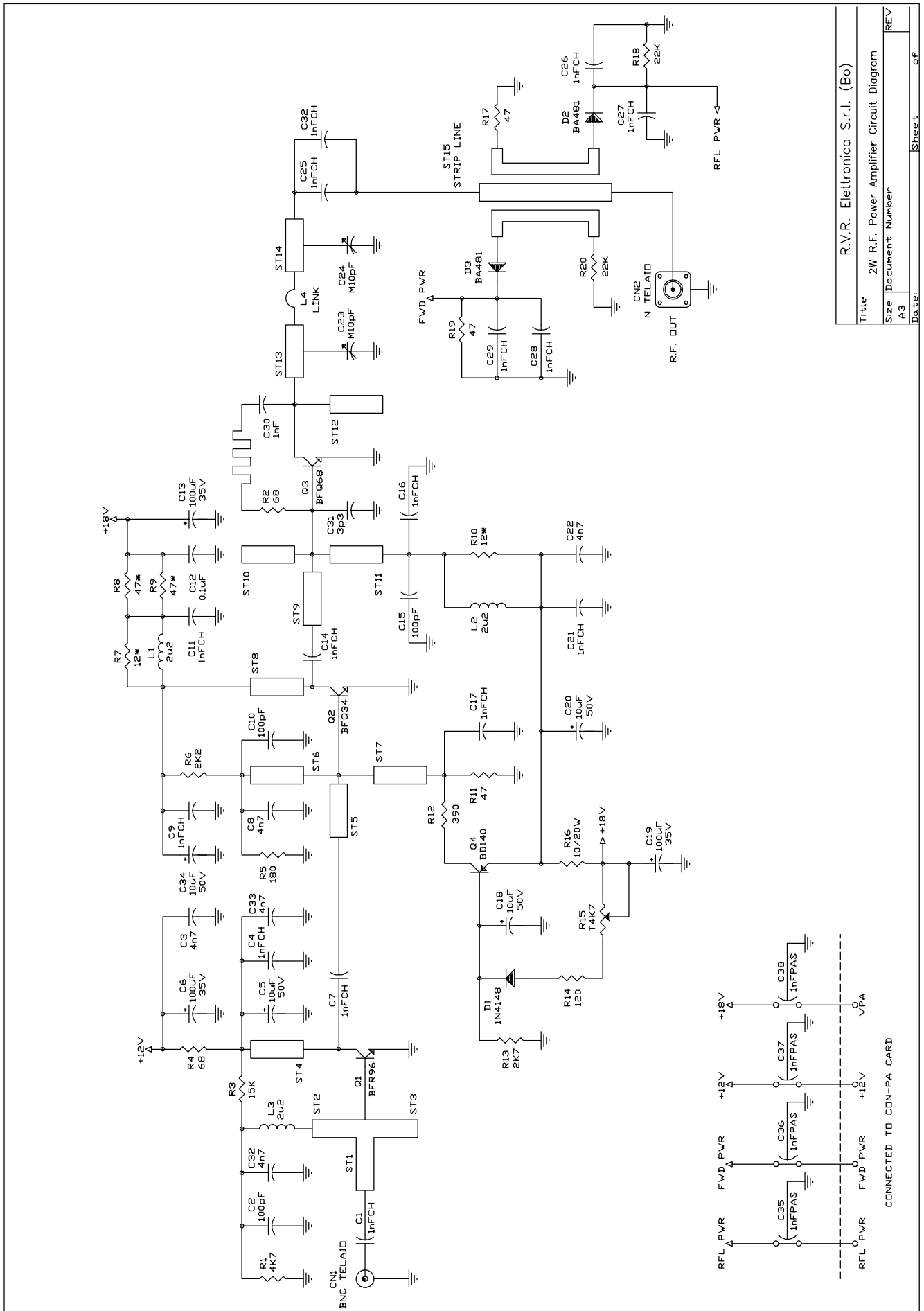

R.V.R. Elettronica S.r.l. (Bo)

Title 2W R.F. Power Amplifier Circuit Diagram

Size Document Number REV

Date: Sheet of

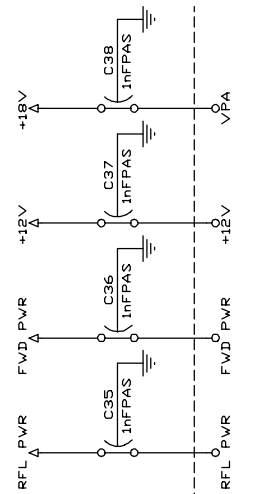

CONNECTED TO CON-PA CARD

2W R.F. Power Amplifier

Bill of Materials

Pag. 1

Item	Quantity	Reference	Part	Description	Part Order Code
1	1	R16	10/20W	RESISTOR 20W	RAF020KH0010
2	2	R7,R10	12*	RESISTOR 1/2W 5%	RSC1/2JH0012
3	3	R11,R17, R19	47	RESISTOR 1/4W 5%	RSC1/4JH0047
4	2	R8,R9	47*	RESISTOR 1/2W 5%	RSC1/2JH0047
5	2	R2,R4	68	RESISTOR 1/4W 5%	RSC1/4JH0068
6	1	R14	120	RESISTOR 1/4W 5%	RSC1/4JH0120
7	1	R5	180	RESISTOR 1/4W 5%	RSC1/4JH0180
8	1	R12	390	RESISTOR 1/4W 5%	RSC1/4JH0390
9	1	R6	2K2	RESISTOR 1/4W 5%	RSC1/4JK02,2
10	1	R13	2K7	RESISTOR 1/4W 5%	RSC1/4JK02,7
11	1	R1	4K7	RESISTOR 1/4W 5%	RSC1/4JK04,7
12	1	R3	15K	RESISTOR 1/4W 5%	RSC1/4JK0015
13	2	R18,R20	22K	RESISTOR 1/4W 5%	RSC1/4JK0022
14	1	R15	T4K7	TRIM.REG.VERT. 10mm	RVTD10VK04,7
15	1	C31	3p3	CERAMIC CAPACITOR NP0	CKM3,3BJ600C
16	2	C23,C24	M10pF	PRECISION TRIMMER CAP.	CVA100BK101
17	3	C2,C10,C15	100pF	CERAMIC CAPACITOR NP0	CKM101BJ600C
18	1	C30	1nF	CERAMIC CAPACITOR	CKM102BK600P
19	15	C1,C4,C7, C9,C11,C14, C16,C17,C21, C25,C26,C27, C28,C29,C32	1nFCH	CERAMIC CHIP CAPACITOR	CCC102AJ500
20	4	C35,C36, C37,C38	1nFPAS	CERAMIC THROUGH CAPAC.	CDP102XK500
21	5	C3,C8,C22, C32,C33	4n7	CERAMIC CAPACITOR	CKM472BK600P
22	1	C12	0.1uF	CERAMIC CAPACITOR	CKM104BK600P
23	4	C5,C18, C20,C34	10UuF	ELECTROLYTIC CAPACITOR	CEA106AM350
24	3	C6,C13,C19	100uF	ELECTROLYTIC CAPACITOR	CEA107BM350
25	3	L1,L2,L3	2u2	RF CHOKE	IMP02U2A

2W R.F. Power Amplifier			Bill of Materials		Pag. 2
Item	Quantity	Reference	Part	Description	Part Order Code
26	1	L4	LINK	LINK FILO ARG. 1mm	CAVARG1000
27	1	CN1	BNC TELAIO	CONN. BNC A TELAIO	CNTBNCFPV
28	1	CN2	N TELAIO	CONN. N A TELAIO	CNTNFPFL
29	1	D1	1N4148	SILICON DIODE	DIS1N4148
30	2	D2,D3	BA481	HOT CARRIER DIODE	DHCBA481
31	1	Q4	BD140	PNP TRANSISTOR	TRNBD140
32	1	Q2	BFQ34	NPN RF TRANSISTOR	TRNBFQ34
33	1	Q3	BFQ68	NPN RF TRANSISTOR	TRNBFQ68
34	1	Q1	BFR96	NPN RF TRANSISTOR	TRNBFR96
35	15	ST1,ST2, ST3,ST4, ST5,ST6, ST7,ST8, ST9,ST10, ST11,ST12, ST13,ST14, ST15	STRIP LINE	STRIP LINE	

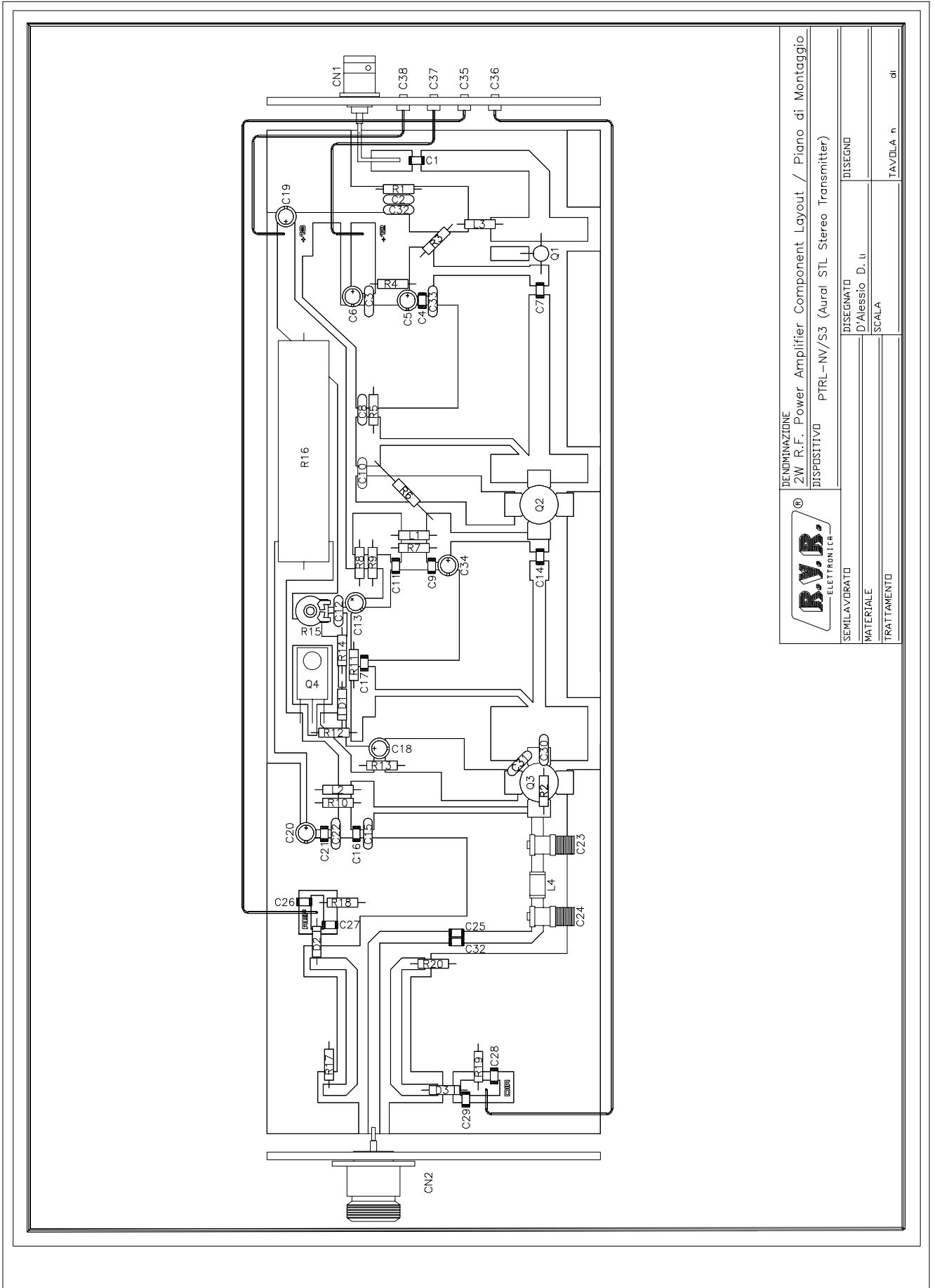

	DENOMINAZIONE	
	2W R.F. Power Amplifier Component Layout / Piano di Montaggio	
SEMILAVORATO	DISPOSITIVO	
	PTRL-NV/S3 (Aural STL Stereo Transmitter)	
	DISEGNATO D'Alessio D. u.	DISEGNO SCALA
TRATTAMENTO	TAVOLA n	di

5W R.F. POWER AMPLIFIER (VERS.1)
FREQUENCY RANGE 806-870 MHZ & 870-950 MHZ

- A) Circuit Diagram
- B) Bill of Materials
- C) Layout

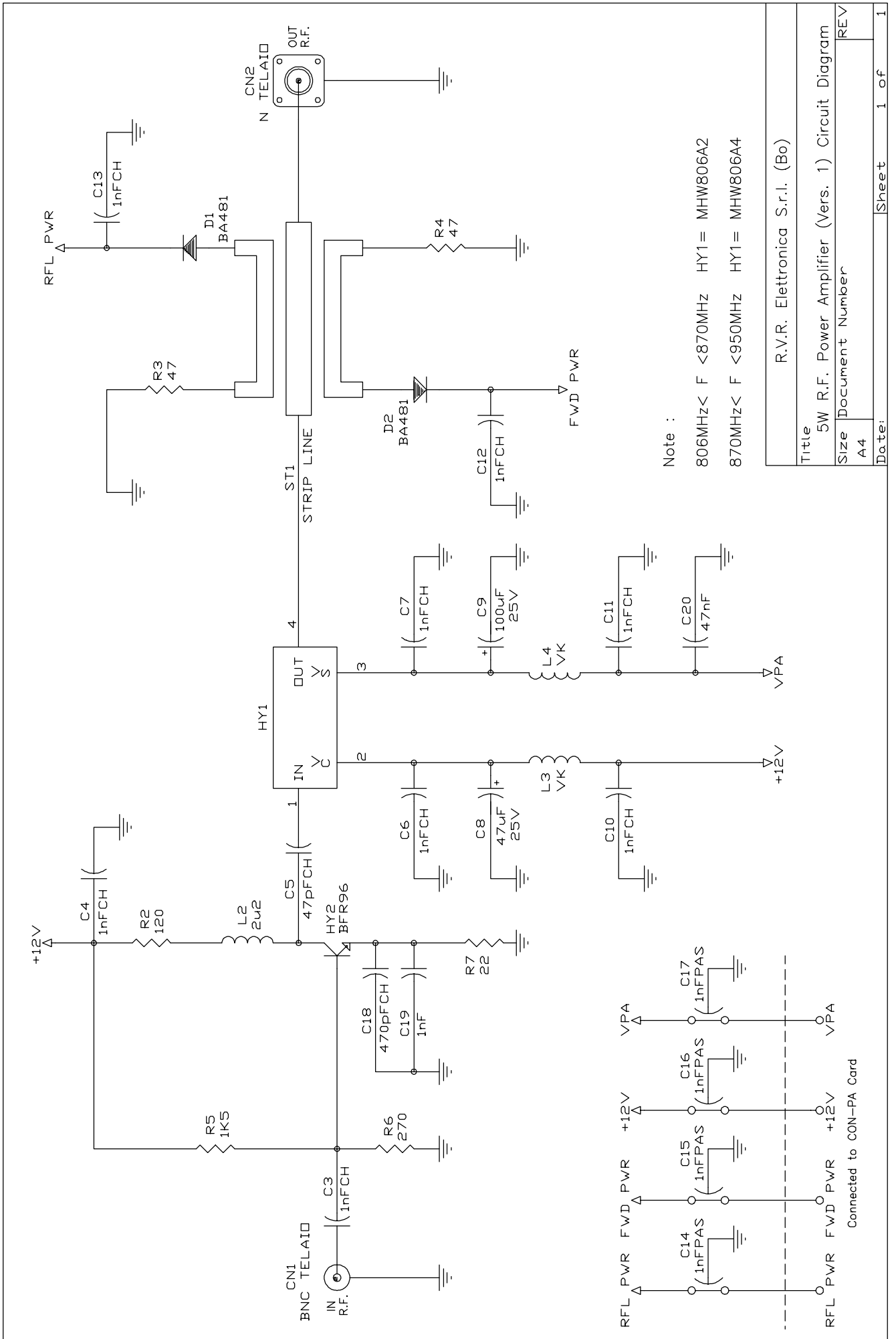

5W R.F. Power Amplifier (Vers.1)

Bill of Materials

Pag. 1

Item	Quantity	Reference	Part	Description	Part Order Code
1	1	R7	22	RESISTOR 1/4W 5%	RSC1/4JH0022
2	2	R3,R4	47	RESISTOR 1/4W 5%	RSC1/4JH0047
3	1	R2	120	RESISTOR 1/4W 5%	RSC1/4JH0120
4	1	R6	270	RESISTOR 1/4W 5%	RSC1/4JH0270
5	1	R5	1K5	RESISTOR 1/4W 5%	RSC1/4JK01,5
6	1	C5	47pFCH	CERAMIC CHIP CAPACITOR	CCC470AJ500
7	1	C18	470pFCH	CERAMIC CHIP CAPACITOR	CCC471AJ500
8	1	C19	1nF	CERAMIC CAPACITOR	CKM102BK600P
9	8	C3,C4,C6, C7,C10,C11, C12,C13	1nFCH	CERAMIC CHIP CAPACITOR	CCC102AJ500
10	4	C14,C15, C16,C17	1nFPAS	CERAMIC THROUGH CAPAC.	CDP102XK500
11	1	C20	47nF	CERAMIC CAPACITOR	CKM473BK600P
12	1	C8	47uF	ELECTROLYTIC CAPACITOR	CEA476BM630
13	1	C9	100uF	ELECTROLYTIC CAPACITOR	CEA107BM350
14	1	L2	2u2	RF CHOKE	IMP02U2A
15	2	L3,L4	VK	RF CHOKE	IMPVK00A
16	1	CN1	BNC TELAIO	CONN. BNC A TELAIO	CNTBNCFPV
17	1	CN2	N TELAIO	CONN. N A TELAIO	CNTNFPFL
18	2	D1,D2	BA481	HOT CARRIER DIODE	DHCBA481
19	1	HY2	BFR96	NPN RF TRANSISTOR	TRNBFR96
20	1	HY1	MHW806A	HYB.P.A. MHW806A (2/4)	MIBMHW806A2/4
21	1	ST1	STRIP LINE	STRIP LINE	

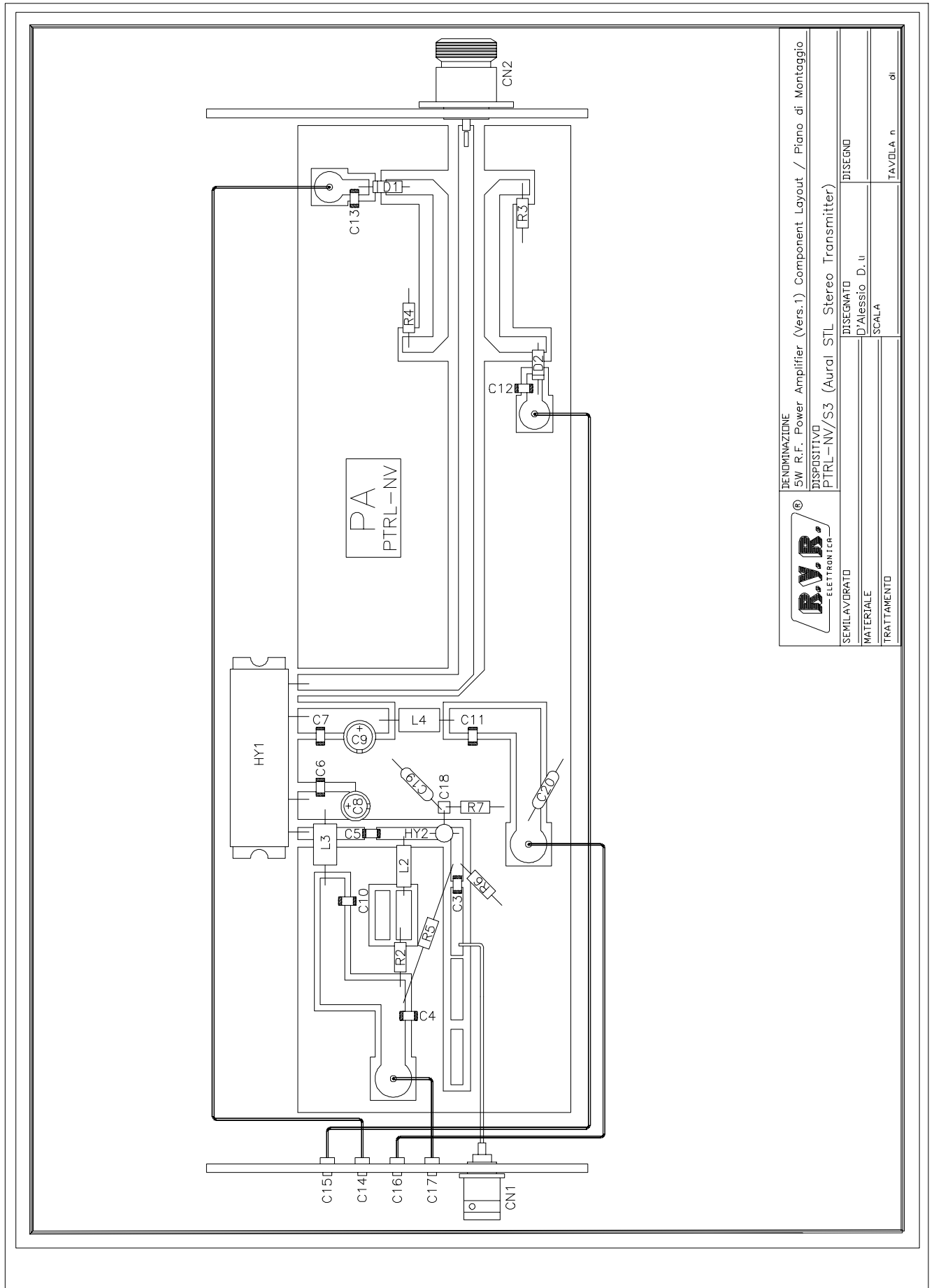

5W R.F. POWER AMPLIFIER (VERS.2)
FREQUENCY RANGE 806-870 MHZ & 870-950 MHZ

- A) Circuit Diagram
- B) Bill of Materials
- C) Layout

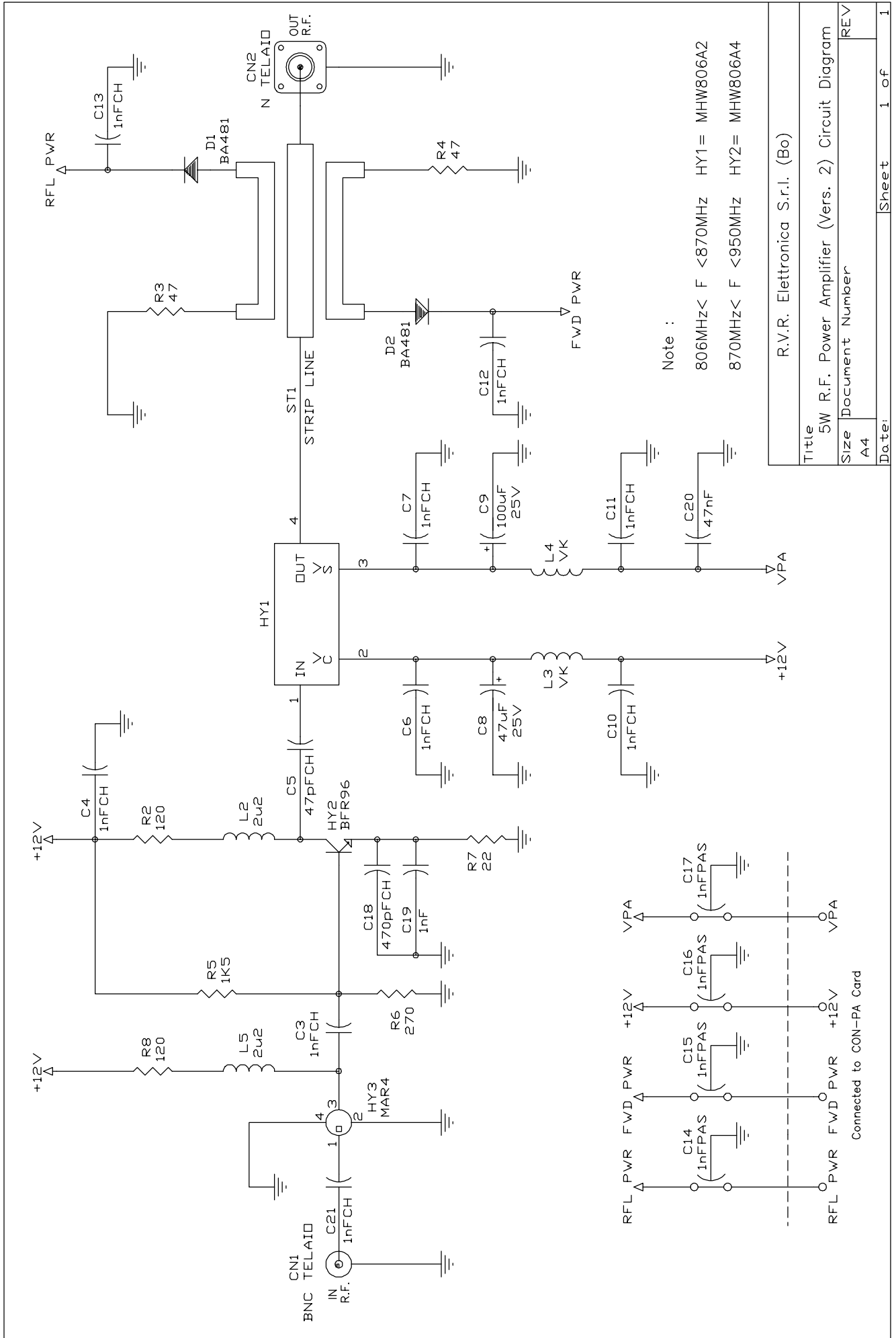



5W R.F. Power Amplifier (Vers.2)

Bill of Materials

Pag. 1

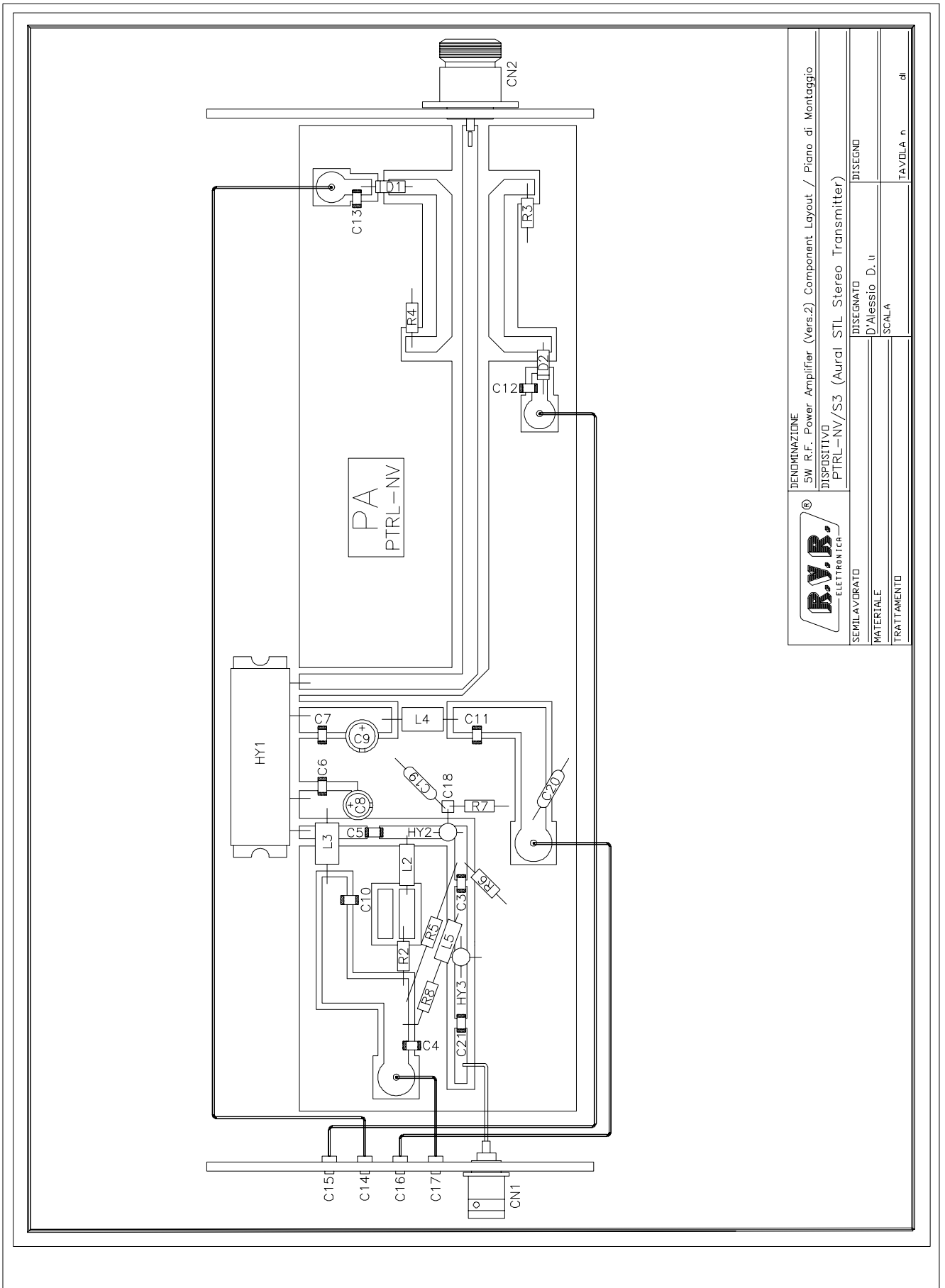
Item	Quantity	Reference	Part	Description	Part Order Code
1	1	R7	22	RESISTOR 1/4W 5%	RSC1/4JH0022
2	2	R3,R4	47	RESISTOR 1/4W 5%	RSC1/4JH0047
3	2	R2,R8	120	RESISTOR 1/4W 5%	RSC1/4JH0120
4	1	R6	270	RESISTOR 1/4W 5%	RSC1/4JH0270
5	1	R5	1K5	RESISTOR 1/4W 5%	RSC1/4JK01,5
6	1	C5	47pFCH	CERAMIC CHIP CAPACITOR	CCC470AJ500
7	1	C18	470pFCH	CERAMIC CHIP CAPACITOR	CCC471AJ500
8	1	C19	1nF	CERAMIC CAPACITOR	CKM102BK600P
9	9	C3,C4,C6, C7,C10,C11, C12,C13,C21	1nFCH	CERAMIC CHIP CAPACITOR	CCC102AJ500
10	4	C14,C15, C16,C17	1nFPAS	CERAMIC THROUGH CAPAC.	CDP102XK500
11	1	C20	47nF	CERAMIC CAPACITOR	CKM473BK600P
12	1	C8	47uF	ELECTROLYTIC CAPACITOR	CEA476BM630
13	1	C9	100uF	ELECTROLYTIC CAPACITOR	CEA107BM350
14	2	L2,L5	2u2	RF CHOKE	IMP02U2A
15	2	L3,L4	VK	RF CHOKE	IMPVK00A
16	1	CN1	BNC TELAIO	CONN. BNC A TELAIO	CNTBNCFPV
17	1	CN2	N TELAIO	CONN. N A TELAIO	CNTNFPFL
18	2	D1,D2	BA481	HOT CARRIER DIODE	DHCBA481
19	1	HY2	BFR96	NPN RF TRANSISTOR	TRNBFR96
20	1	HY3	MAR4	HYBRID AMP MAR4	MIBMAR4
21	1	HY1	MHW806A	HYB. P.A. MHW806A (2/4)	MIBMHW806A2/4
22	1	ST1	STRIP LINE	STRIP LINE	



	DENOMINAZIONE	
	SW R.F. Power Amplifier (Vers.2) Component Layout / Piano di Montaggio	
SEMILAVORATO	DISPOSITIVO	
	PTRL-NV/S3 (Aural STL Stereo Transmitter)	
MATERIALE	DISEGNATO	
	D'Alessio D. II	
TRATTAMENTO	SCALA	
	TAVOLA n°	
		di

10W R.F. POWER AMPLIFIER (VERS.1)
FREQUENCY RANGE 200-240 MHZ

- A) Circuit Diagram
- B) Bill of Materials
- C) Layout

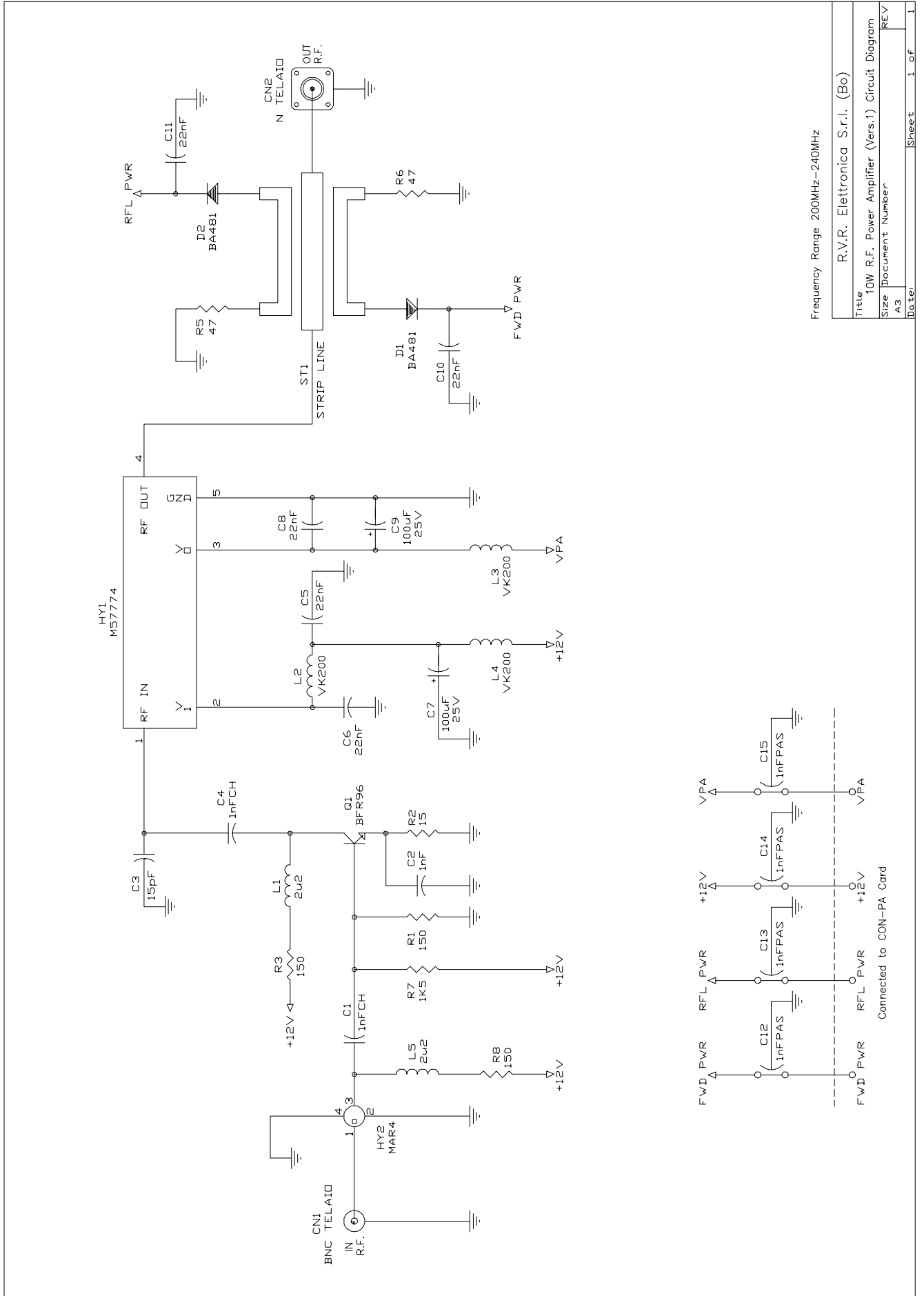

10W R.F. Power Amplifier (Vers.1)				Bill of Materials	Pag. 1
Item	Quantity	Reference	Part	Description	Part Order Code
1	1	R2	15	RESISTOR 1/4W 5%	RSC1/4JH0015
2	2	R5,R6	47	RESISTOR 1/4W 5%	RSC1/4JH0047
3	3	R1,R3,R8	150	RESISTOR 1/4W 5%	RSC1/4JH0150
4	1	R7	1K5	RESISTOR 1/4W 5%	RSC1/4JK01,5
5	1	C3	15pF	CERAMIC CAPACITOR NP0	CKM150BJ600C
6	1	C2	1nF	CERAMIC CAPACITOR	CKM102BK600P
7	2	C1,C4	1nFCH	CERAMIC CHIP CAPACITOR	CCC102AJ500
8	4	C12,C13, C14,C15	1nFPAS	CERAMIC THROUGH CAPAC.	CDP102XK500
9	5	C5,C6,C8, C10,C11	22nF	CERAMIC CAPACITOR	CKM223BK600P
10	2	C7,C9	100uF	ELECTROLYTIC CAPACITOR	CEA107BM350
11	2	L1,L5	2u2	RF CHOKE	IMP02U2A
12	3	L2,L3,L4	VK200	RF CHOKE	IMPVK200
13	1	CN1	BNC TELAIO	CONN. BNC A TELAIO	CNTBNCFPV
14	1	CN2	N TELAIO	CONN. N A TELAIO	CNTNFPFL
15	2	D1,D2	BA481	HOT CARRIER DIODE	DHCBA481
16	1	Q1	BFR96	NPN RF TRANSISTOR	TRNBFR96
17	1	HY2	MAR4	HYBRID AMP MAR4	MIBMAR4
18	1	HY1	M57774	HYBRID POW AMP M57774	MIBM57774
19	1	ST1	STRIP LINE	STRIP LINE	

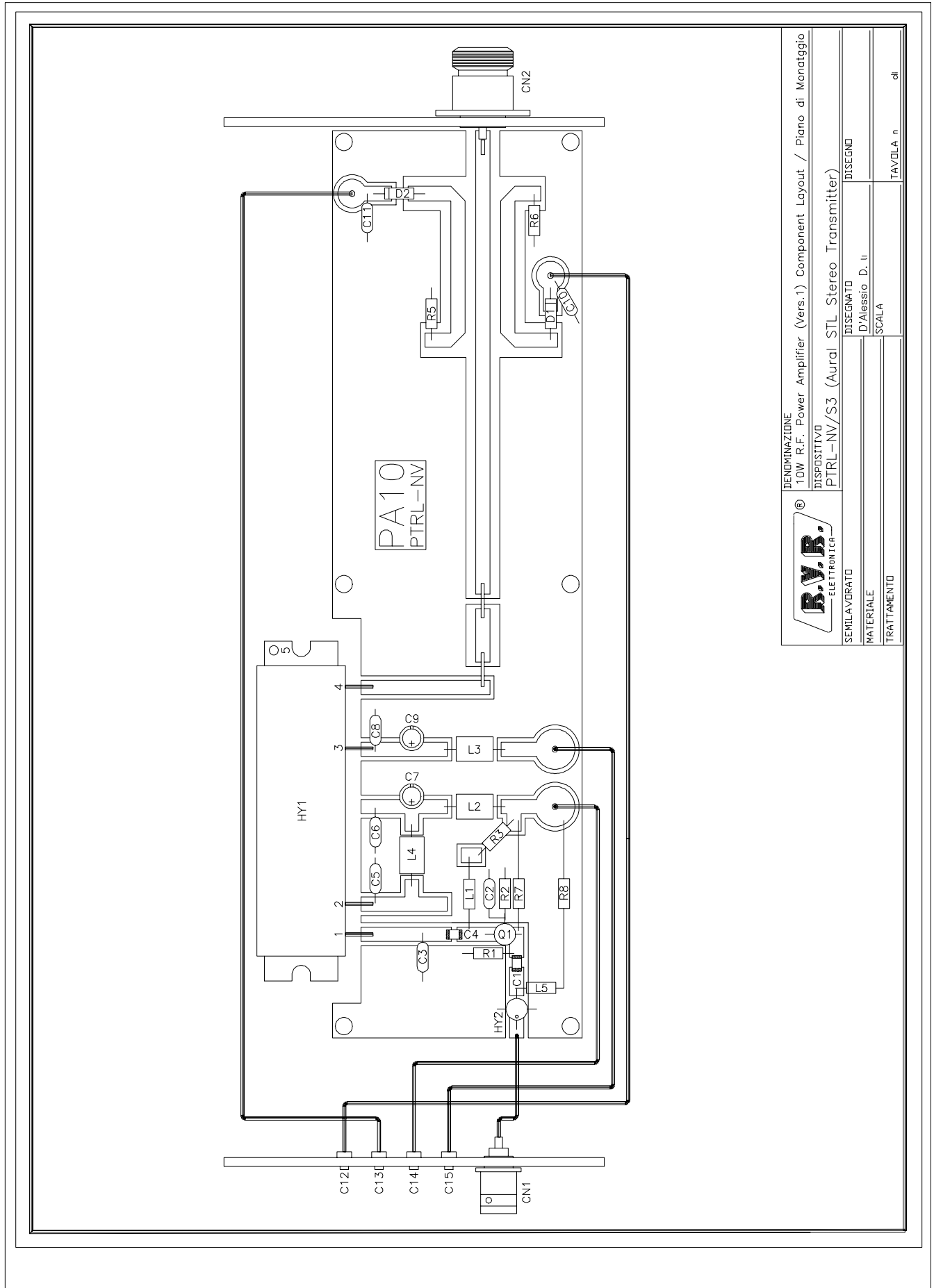

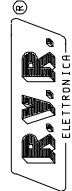
	DENOMINAZIONE 10W R.F. Power Amplifier (Vers.1) Component Layout / Piano di Montaggio	
	DISPOSITIVO PTRL-NV/S3 (Aural STL Stereo Transmitter)	
SEMILAVORATO	DISegnATO	DISIGNO
MATERIALE	D/Alessio D. U.	
TRATTAMENTO	SCALA	TAVOLA n. di

10W R.F. POWER AMPLIFIER (VERS.2)
FREQUENCY RANGE 310-340 MHZ & 380-400 MHZ

- A) Circuit Diagram
- B) Bill of Materials
- C) Layout

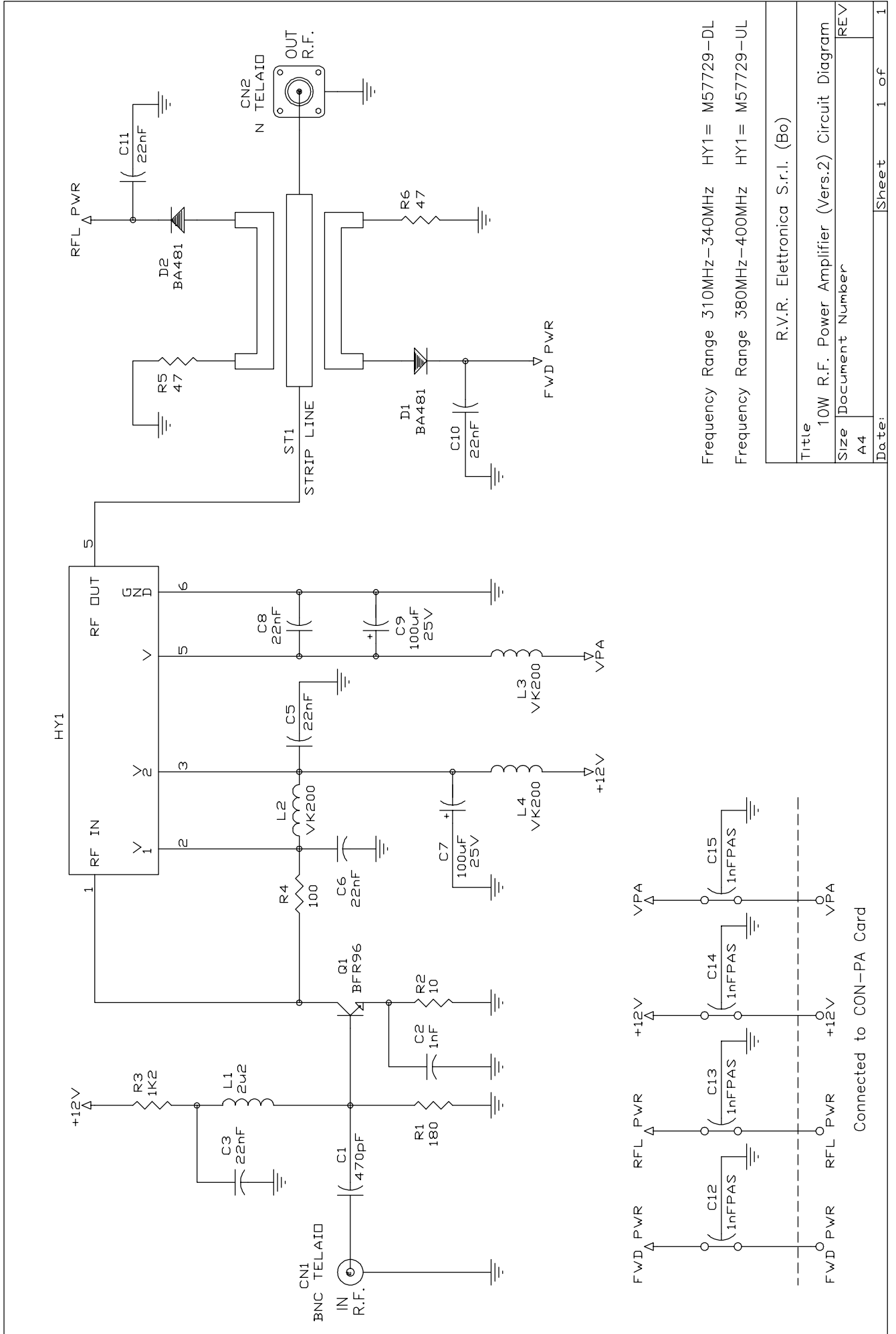



10W R.F. Power Amplifier (Vers.2)

Bill of Materials

Pag. 1

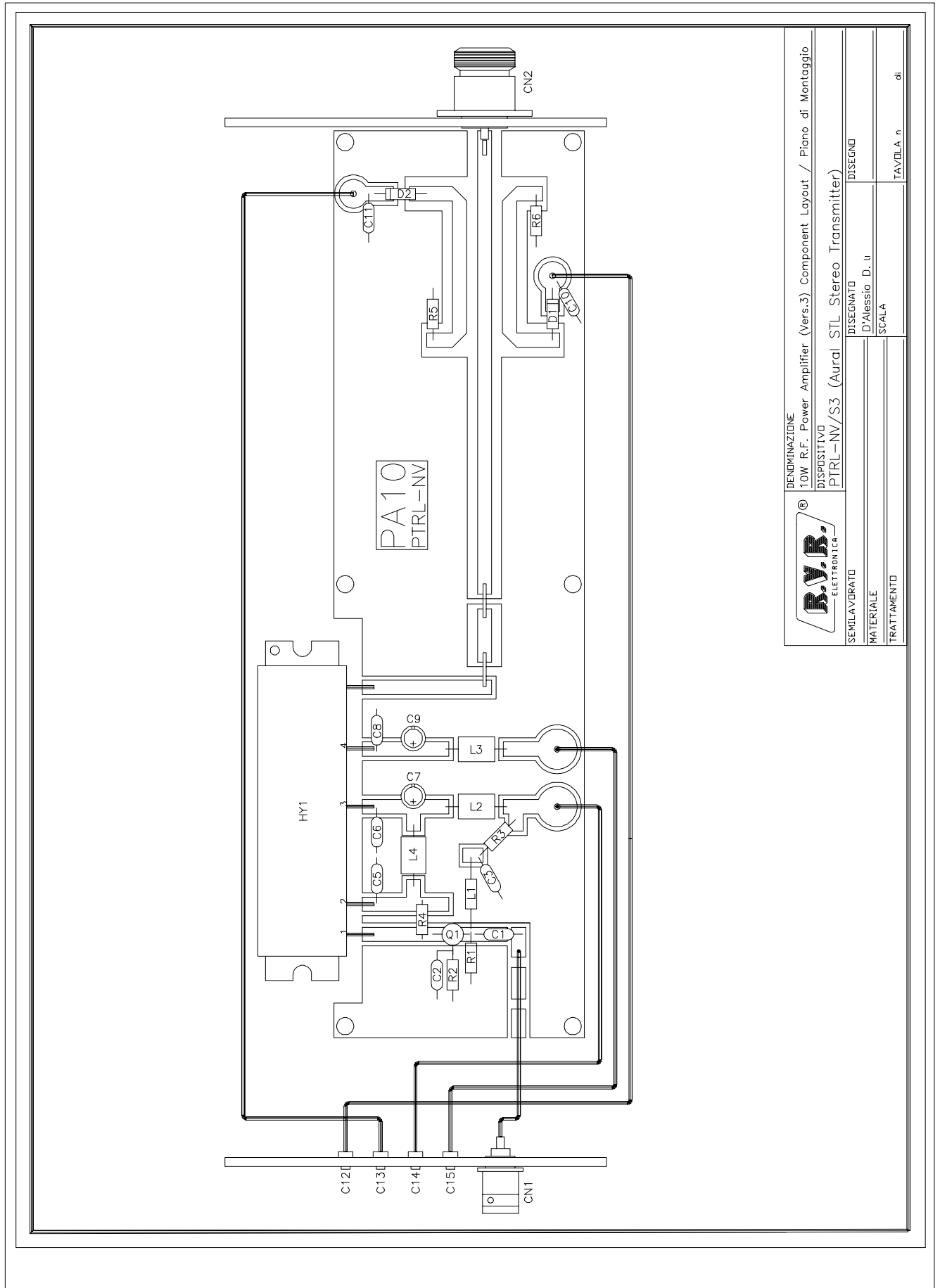
Item	Quantity	Reference	Part	Description	Part Order Code
1	1	R2	10	RESISTOR 1/4W 5%	RSC1/4JH0010
2	2	R5,R6	47	RESISTOR 1/4W 5%	RSC1/4JH0047
3	1	R4	100	RESISTOR 1/4W 5%	RSC1/4JH0100
4	1	R1	180	RESISTOR 1/4W 5%	RSC1/4JH0180
5	1	R3	1K2	RESISTOR 1/4W 5%	RSC1/4JK01,2
6	1	C1	470pF	CERAMIC CAPACITOR	CKM471BK600P
7	1	C2	1nF	CERAMIC CAPACITOR	CKM102BK600P
8	4	C12,C13, C14,C15	1nFPAS	CERAMIC THROUGH CAPAC.	CDP102XK500
9	6	C3,C5,C6, C8,C10,C11	22nF	CERAMIC CAPACITOR	CKM223BK600P
10	2	C7,C9	100uF	ELECTROLYTIC CAPACITOR	CEA107BM350
11	1	L1	2u2	RF CHOKE	IMP02U2A
12	3	L2,L3,L4	VK200	RF CHOKE	IMPVK200
13	1	CN1	BNC TELAIO	CONN. BNC A TELAIO	CNTBNCFPV
14	1	CN2	N TELAIO	CONN. N A TELAIO	CNTNFPFL
15	2	D1,D2	BA481	HOT CARRIER DIODE	DHCBA481
16	1	Q1	BFR96	NPN RF TRANSISTOR	TRNBFR96
17	1	HY1	M57729-UL	HYB. P.A. M57729-UL	MIBM57729-UL
18	1	ST1	STRIP LINE	STRIP LINE	



	DENOMINAZIONE	
	LOW R.F. Power Amplifier (Vers.3) Component Layout / Piano di Montaggio	
SEMILAVORATO MATERIALE TRATTAMENTO	DISPOSITIVO	
	PTRL-NV/S3 (Aural STL Stereo Transmitter)	
	DISEGNATO	DISEGNO
	D'Alessio D. U.	
	SCALA	TAVOLA n
		di

10W R.F. POWER AMPLIFIER (VERS.2)

FREQUENCY RANGE 470-512 MHZ

- A) Circuit Diagram
- B) Bill of Materials
- C) Layout

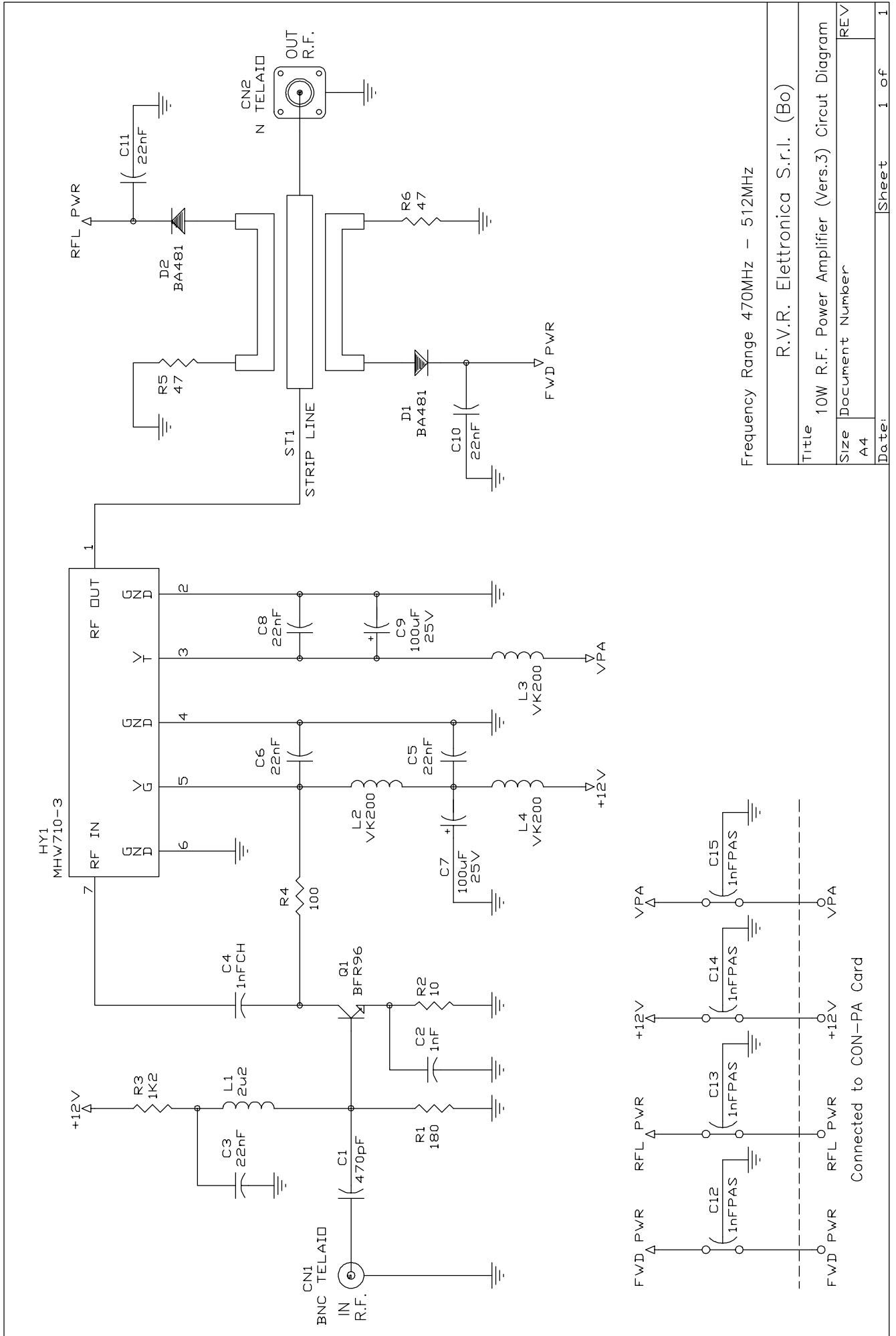

Frequency Range 470MHz - 512MHz

Title		R.V.R. Elettronica S.r.l. (Bo)	
Size		10W R.F. Power Amplifier (Vers.3) Circuit Diagram	
Document Number		REV	
A4	Sheet	1	of 1

10W R.F. Power Amplifier (Vers.3)

Bill of Materials

Pag. 1

Item	Quantity	Reference	Part	Description	Part Order Code
1	1	R2	10	RESISTOR 1/4W 5%	RSC1/4JH0010
2	2	R5,R6	47	RESISTOR 1/4W 5%	RSC1/4JH0047
3	1	R4	100	RESISTOR 1/4W 5%	RSC1/4JH0100
4	1	R1	180	RESISTOR 1/4W 5%	RSC1/4JH0180
5	1	R3	1K2	RESISTOR 1/4W 5%	RSC1/4JK01,2
6	1	C1	470pF	CERAMIC CAPACITOR	CKM471BK600P
7	1	C2	1nF	CERAMIC CAPACITOR	CKM102BK600P
8	1	C4	1nFCH	CERAMIC CHIP CAPACITOR	CCC102AJ500
9	4	C12,C13, C14,C15	1nFPAS	CERAMIC THROUGH CAPAC.	CDP102XK500
10	6	C3,C5,C6, C8,C10,C11	22nF	CERAMIC CAPACITOR	CKM223BK600P
11	2	C7,C9	100uF	ELECTROLYTIC CAPACITOR	CEA107BM350
12	1	L1	2u2	RF CHOKE	IMP02U2A
13	3	L2,L3,L4	VK200	RF CHOKE	IMPVK200
14	1	CN1	BNC TELAIO	CONN. BNC A TELAIO	CNTBNCFPV
15	1	CN2	N TELAIO	CONN. N A TELAIO	CNTNFPFL
16	2	D1,D2	BA481	HOT CARRIER DIODE	DHCBA481
17	1	Q1	BFR96	NPN RF TRANSISTOR	TRNBFR96
18	1	HY1	MHW710-3	HYBRID P.A. MHW710-3	MIBMHW710-3
19	1	ST1	STRIP LINE	STRIP LINE	

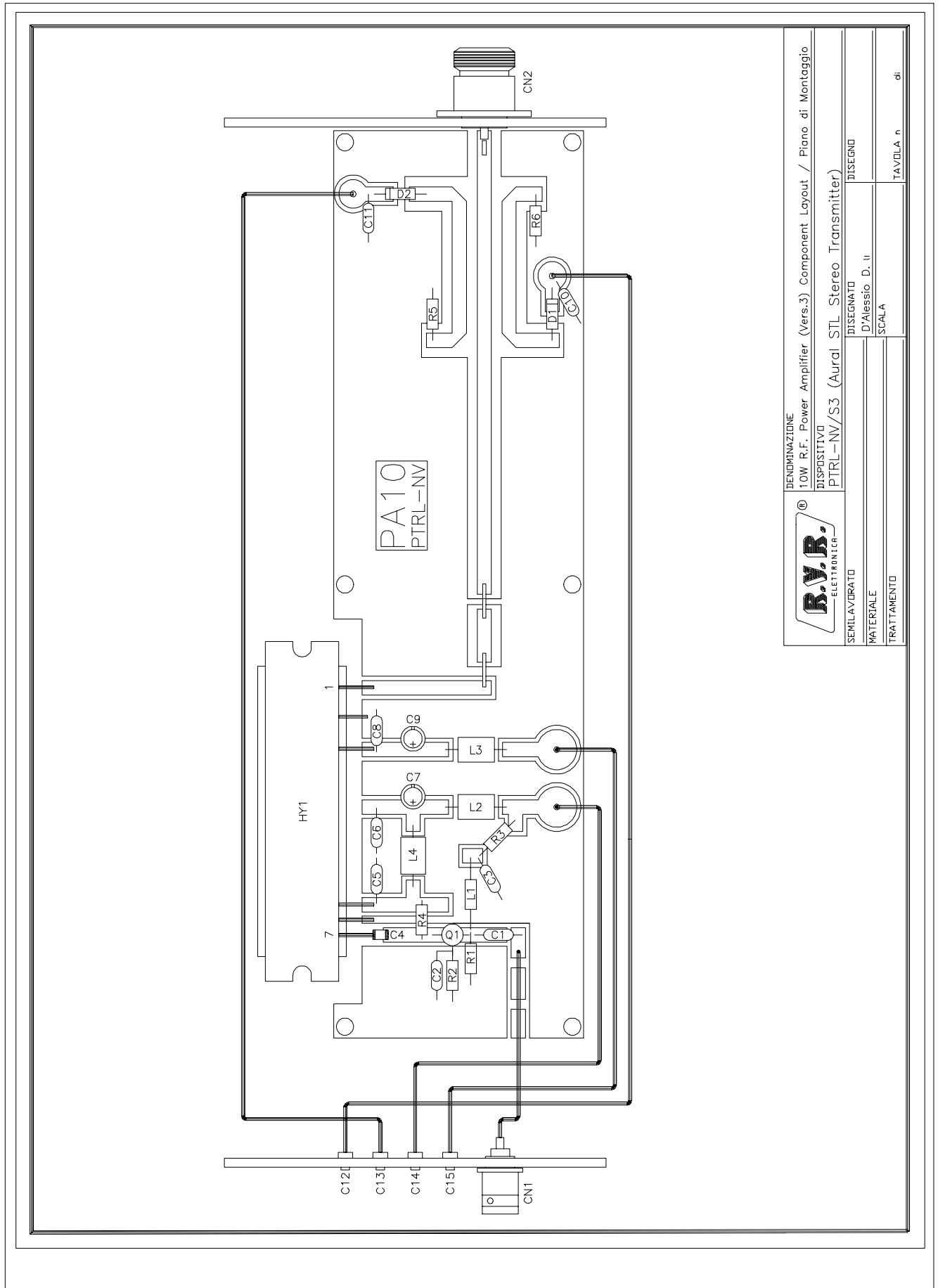

	DENOMINAZIONE	
	LOW R.F. Power Amplifier (Vers.3) Component Layout / Piano di Montaggio	
SEMILAVORATO	DISPOSITIVO	
	PTRL-NV/S3 (Aural STL Stereo Transmitter)	
MATERIALE	DISEGNATO	
	D'Alessio D. U.	
TRATTAMENTO	SCALA	
	TAVOLA n di	

CON- PA CARD

- A) Circuit Diagram
- B) Bill of Materials
- C) Layout

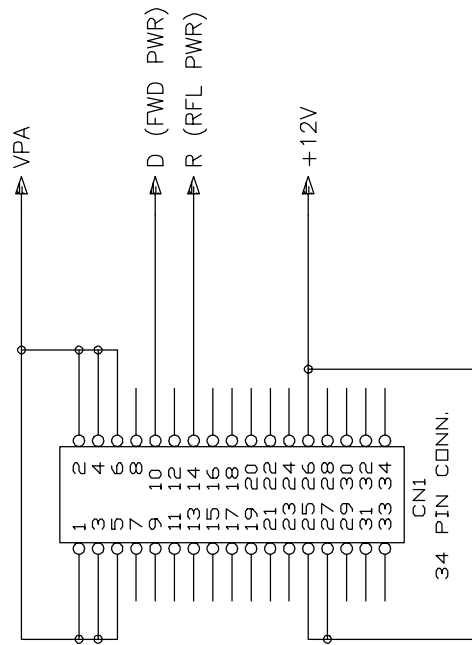

Title		R.V.R. Elettronica S.r.l. (Bo)
Size		A4
Document Number		CON-PA Card Circuit Diagram
REV		
Date:	Sheet	of

CON-PA CARD				Bill Of Materials	Page 1
Item	Quantity	Reference	Part	Description	Part Order Code

1	1	CN1	34 P CONN	CONN. M 2*17 P 2.54	CNTMCSFC34P
---	---	-----	-----------	---------------------	-------------

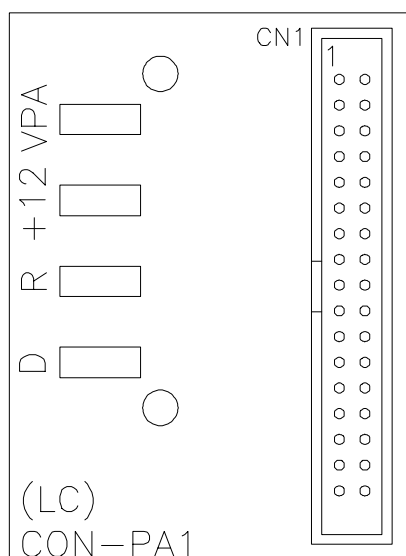

	DENOMINAZIONE	
	CON-PA Card Component Layout / Piano di Montaggio	
DISPOSITIVO		
PTRL-NV/S3 (Aural STL Stereo Transmitter)		
SEMILAVORATO	DISEGNATO	DISEGNO
MATERIALE	D'Alessio D. U.	
TRATTAMENTO	SCALA	TAVOLA n di

INVERTER CARD

- A) Circuit Diagram
- B) Bill of Materials
- C) Layout

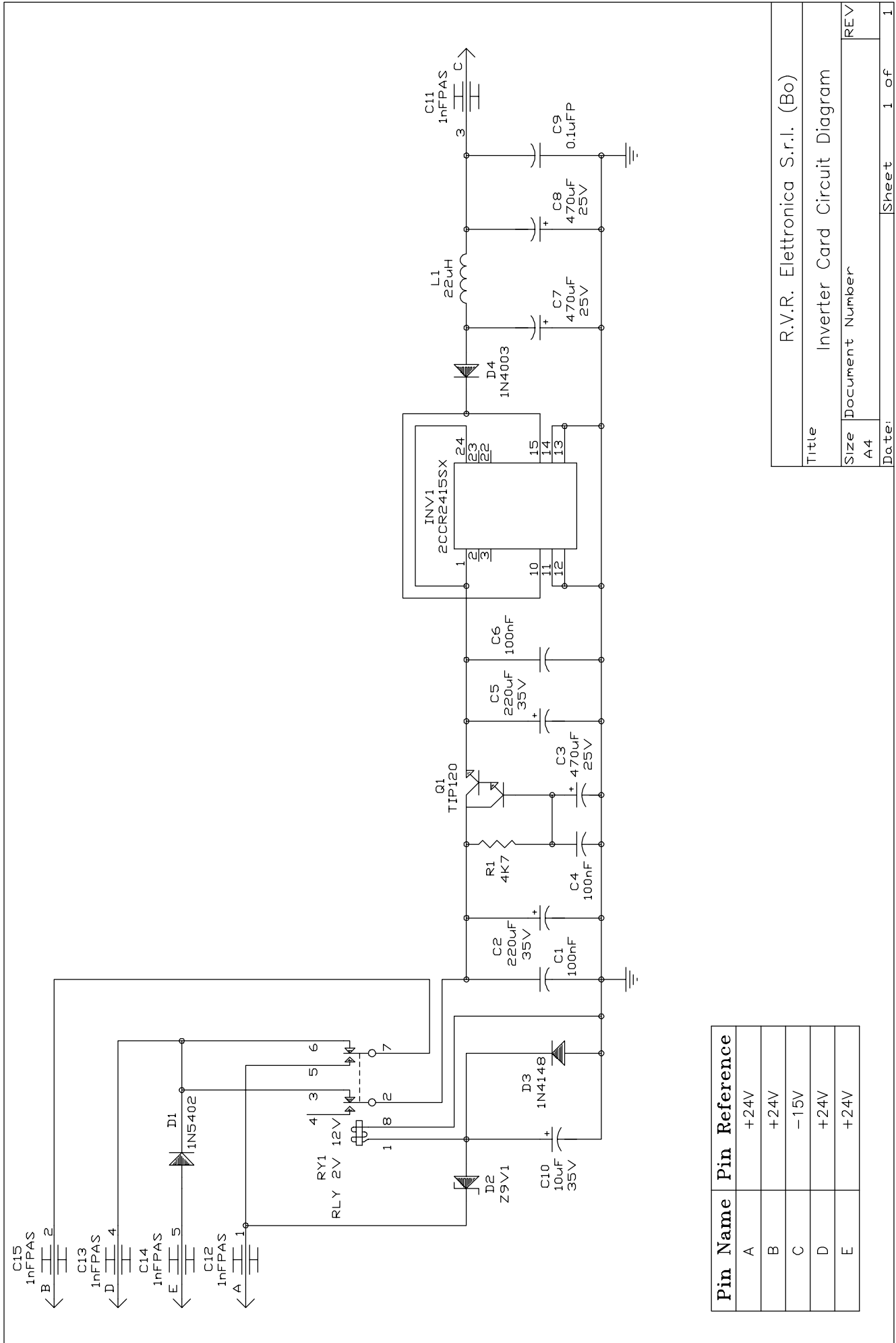

Title		R.V.R. Elettronica S.r.l. (Bo)	
Size		Inverter Card Circuit Diagram	
A4	Document Number	REV	
Date:	Sheet	1	of 1

INVERTER CARD				Bill Of Materials	Page 1
Item	Quantity	Reference	Part	Description	Part Order Code
1	1	R1	4K7	RESISTOR 1/4W 5%	RSC1/4JK04,7
2	3	C1,C4,C6	0.1uF	CERAMIC CAPACITOR	CKM104BK600P
3	1	C9	0.1uFP	POLIESTER CAPACITOR	CPE104DK101
4	1	C10	10uF	ELECTROLYTIC CAPACITOR	CEA106AM350
5	2	C2,C5	220uF	ELECTROLYTIC CAPACITOR	CEA227BM350
6	3	C3,C7,C8	470uF	ELECTROLYTIC CAPACITOR	CEA477BM350
7	1	L1	100uH	RF CHOKE	IMP100UA
8	1	RY1	RL 2V 12V	RELAY 2 VIE 12V	RLDLFHA00212
9	1	D3	1N4148	SILICON DIODE	DIS1N4148
10	1	D4	1N4003	SILICON DIODE 200V	DIS1N4003
11	1	D1	BY255	SILICON DIODE 1000V 3A	DISBY255
12	1	D2	Z9V1	ZENER DIODE 9.1V 0.4W	DIZ9V10W4
13	1	INV1	2CCR2415SX	DC/DC CONV.24Vin 15Vout	2CCR2415SX
14	1	Q1	TIP120	NPN DARLINGTON	TRNTIP120
15	1	CS1	ALIM/1/24	CS CONV. 24/-15 RX-PT	PCBALIM/1/24

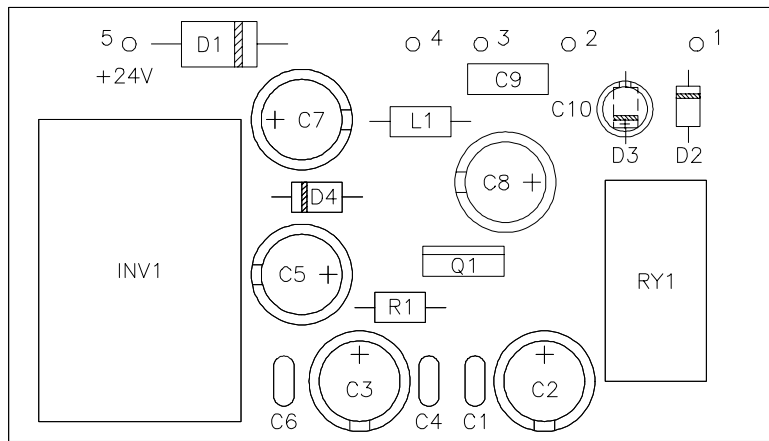

DENOMINAZIONE
Inverter 24VDC/-15VDC Component Layout / Piano di Montaggio

DISPOSITIVO
PTRL-NV/S3 (Aural STL Stereo Transmitter)

SEMILAVORATO

DISEGNATO

DISEGNO

MATERIALE

D'Alessio D. U

TRATTAMENTO

SCALA

TAVOLA n 1 di 1

AUDIO INPUT CARD

- A) Circuit Diagram
- B) Bill of Materials
- C) Layout

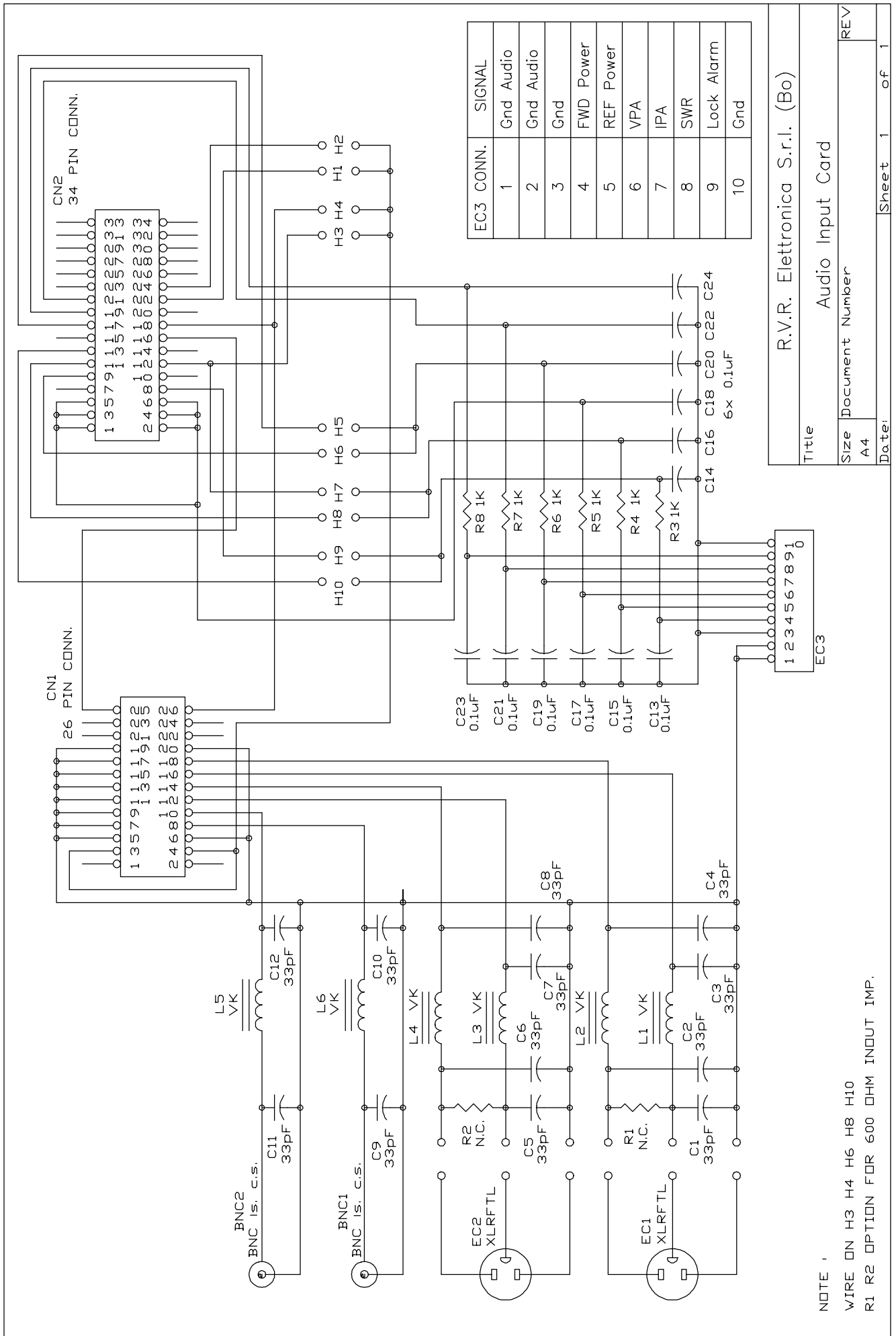

EC3 CONN.	SIGNAL
1	Gnd Audio
2	Gnd Audio
3	Gnd
4	FWD Power
5	REF Power
6	VPA
7	IPA
8	SWR
9	Lock Alarm
10	Gnd

R.V.R. Elettronica S.r.l. (Bo)

Title	
Size	Document Number
A4	
Date:	
Sheet 1	of 1

NOTE :
 WIRE ON H3 H4 H6 H8 H10
 R1 R2 OPTION FOR 600 OHM INPUT IMP.

AUDIO INPUT CARD				Bill Of Materials	Page 1
Item	Quantity	Reference	Part	Description	Part Order Code
1	6	R3,R4,R5, R6,R7,R8	1K	RESISTOR 1/4W 5%	RSC1/4JK0001
2	12	C1,C2,C3, C4,C5,C6, C7,C8,C9, C10,C11,C12	33pF	CERAMIC CAPACITOR NP0	CKM330BJ600C
3	12	C13,C14, C15,C16,C17, C18,C19,C20, C21,C22,C23, C24	0.1uF	CERAMIC CAPACITOR	CKM104BK600P
4	6	L1,L2,L3, L4,L5,L6	VK	RF CHOKE	IMPVK00A
5	2	EC1,EC2	XLRFTL	XLR FEMMINA DA TELAIO	CNTXLRFP3P
6	1	EC3	MORSET.10	MORSET. TELAIO 10 CONT	MORSP10P
7	1	CN1	26 P CONN	CONN. M 2*13 P 2.54	CNTMCSFC26P
8	1	CN2	34 P CONN	CONN. M 2*17 P 2.54	CNTMCSFC34P
9	2	BNC1,BNC2	BNC IS.CS.	CONN. BNC A STAMP. IS.	CNTBNCFCISIS
10	6	JP1,JP2, JP3,JP4, JP5,JP6	WIRE	COLLEGAMENTO A FILO	FILO
11	10	H1,H2,H3, H4,H5,H6, H7,H8,H9, H10	WIRE JUMPER	PONTICELLO A FILO	WIREJUMPER
12	2	R1,R2	N.C.	NOT CONNECTED	

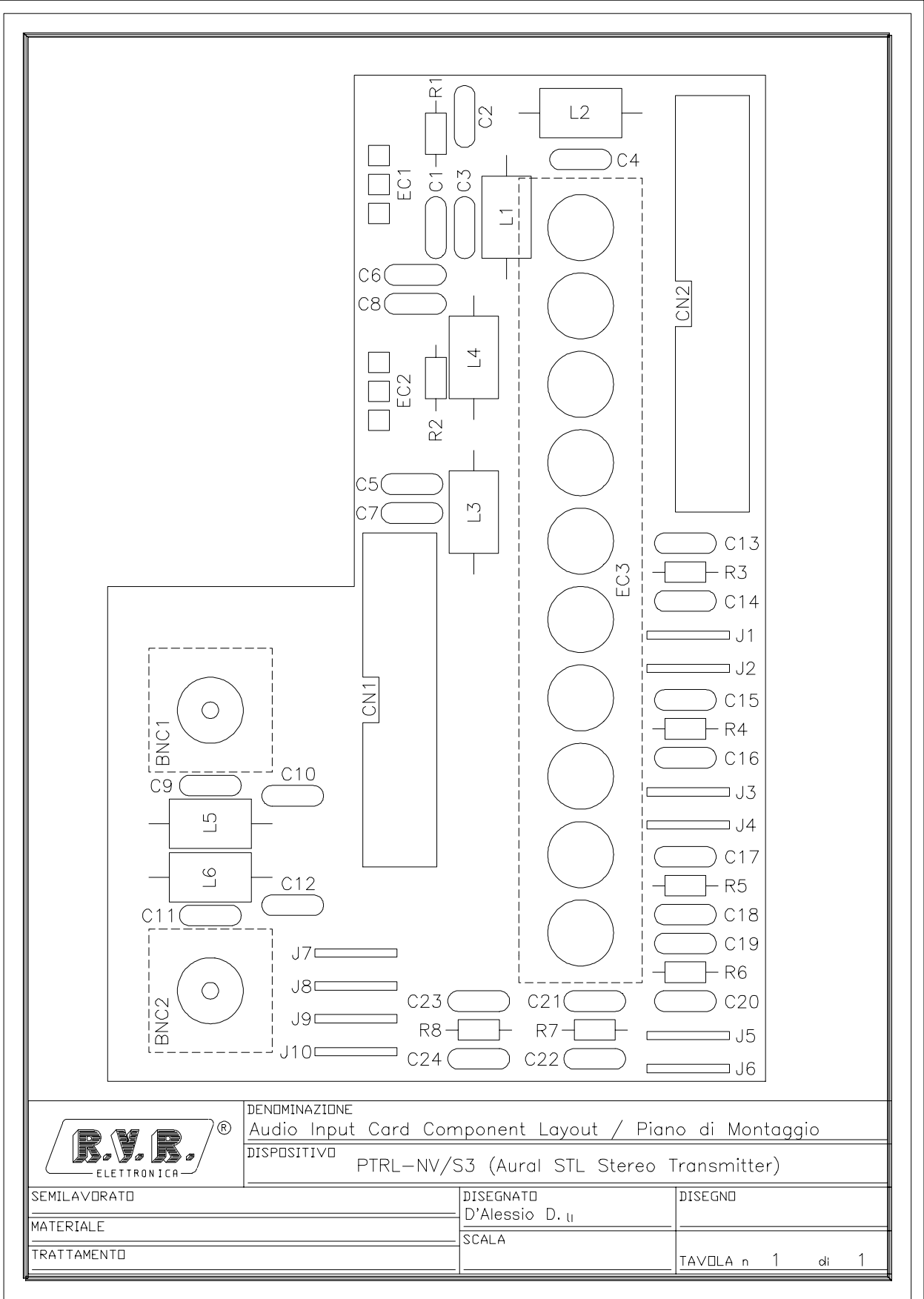

	DENOMINAZIONE	
	Audio Input Card Component Layout / Piano di Montaggio	
	DISPOSITIVO	
	PTRL-NV/S3 (Aural STL Stereo Transmitter)	
SEMILAVORATO	DISEGNATO	DISEGNO
MATERIALE	D'Alessio D. U.	
TRATTAMENTO	SCALA	TAVOLA n 1 di 1

STEREO CODER CARD

- A) Circuit Diagram
- B) Bill of Materials
- C) Layout

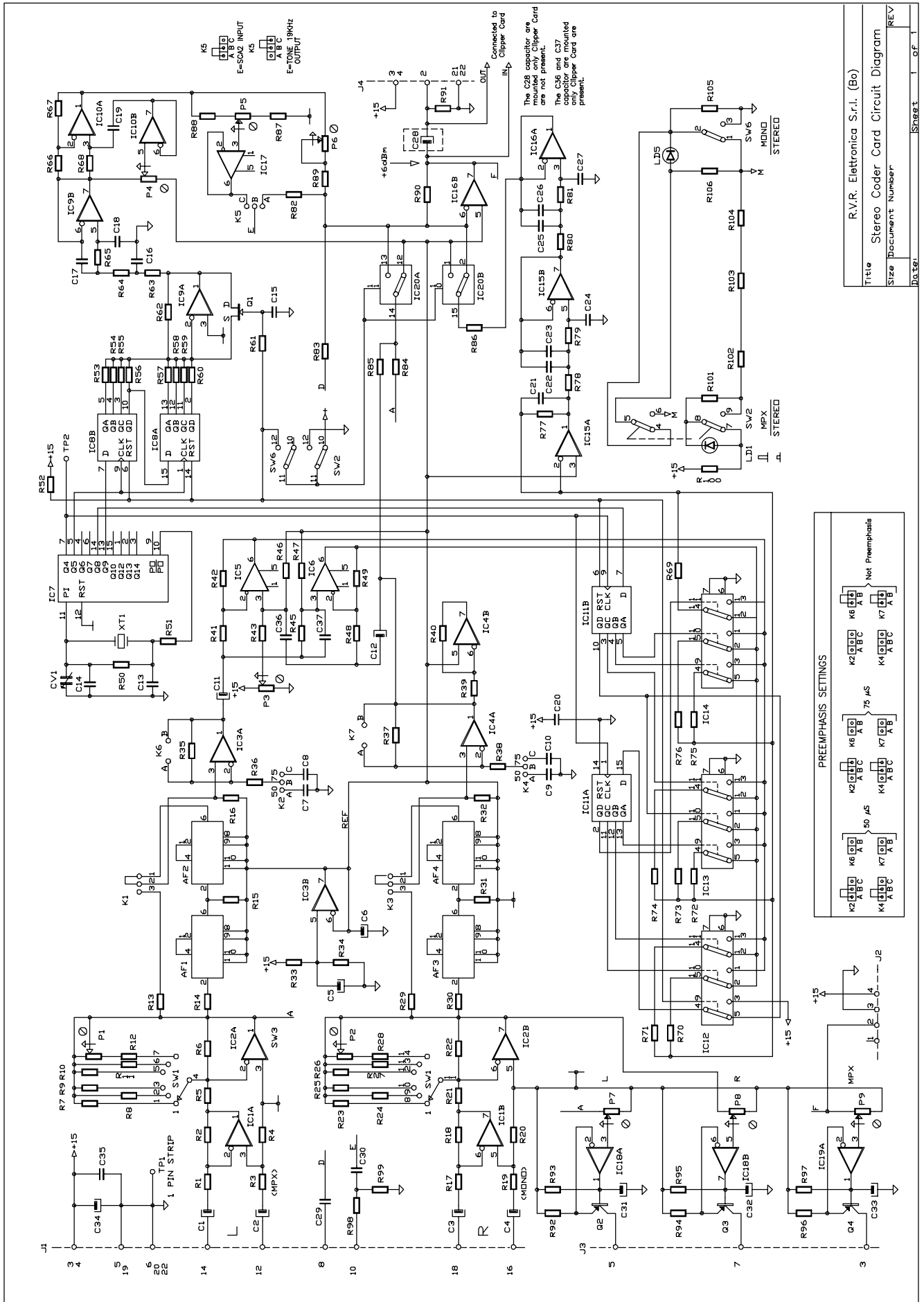

REV	OF	SHEET
Document Number		
Size		
Title	Stereo Coder Card Circuit Diagram	
	R.V.R. Elettronica S.r.l. (Bo)	

Internal Stereo Coder				Bill Of Materials	Page 1
Item	Quantity	Reference	Part	Description	Part Order Code
1	1	R98	100	RESISTOR 1/4W 5%	RSC1/4JH0100
2	5	R46,R47, R101,R105, R106	200 1%	RESISTOR 1/4W 1%	RSC1/4FH0200
3	1	R51	330	RESISTOR 1/4W 5%	RSC1/4JH0330
4	2	R78,R79	464 1%	RESISTOR 1/4W 1%	RSM1/4FH0464
5	1	R87	499 1%	RESISTOR 1/4W 1%	RSM1/4FH0499
6	2	R36,R38	750 1%	RESISTOR 1/4W 1%	RSM1/4FH0750
7	1	R100	1K	RESISTOR 1/4W 5%	RSC1/4JK0001
8	1	R45	1K13 2%	RESISTOR 1/4W 2%	RSM1/4GK1, 13
9	4	R12,R28, R80,R81	1K78 1%	RESISTOR 1/4W 1%	RSM1/4FK1, 78
10	5	R5,R11, R21,R27,R85	2K49 1%	RESISTOR 1/4W 1%	RSM1/4FK2, 49
11	6	R62,R63, R64,R65, R66,R67	3K83 1%	RESISTOR 1/4W 1%	RSC1/4FK3, 83
12	1	R84	4K42 1%	RESISTOR 1/4W 1%	RSM1/4FK4, 42
13	2	R14,R30	4K64 1%	RESISTOR 1/4W 1%	RSM1/4FK4, 64
14	10	R3,R4,R10, R19,R20, R26,R39, R40,R86,R90	5K11 1%	RESISTOR 1/4W 1%	RSM1/4FK5, 11
15	2	R13,R29	5K90 1%	RESISTOR 1/4W 1%	RSM1/4FK5, 90
16	2	R9,R25	7K15 1%	RESISTOR 1/4W 1%	RSM1/4FK7, 15
17	2	R16,R32	7K50 1%	RESISTOR 1/4W 1%	RSM1/4FK7, 50
18	1	R88	9K09 1%	RESISTOR 1/4W 1%	RSM1/4FK9, 09
19	9	R8,R24, R33,R34, R41,R48, R92,R94,R96	10K0 1%	RESISTOR 1/4W 1%	RSC1/4FK10, 0
20	1	R99	10K	RESISTOR 1/4W 5%	RSC1/4JK0010
21	1	R77	12K7 1%	RESISTOR 1/4W 1%	RSM1/4FK12, 7
22	6	R1,R2,R7, R17,R18,R23	14K7 1%	RESISTOR 1/4W 1%	RSM1/4FK14, 7
23	1	R52	15K	RESISTOR 1/4W 5%	RSC1/4JK0015

Internal Stereo Coder				Bill Of Materials	Page 2
Item	Quantity	Reference	Part	Description	Part Order Code
24	2	R42,R49	17K8 1%	RESISTOR 1/4W 1%	RSC1/4FK17,8
25	1	R68	20K0 1%	RESISTOR 1/4W 1%	RSM1/4FK20,0
26	2	R35,R37	21K5 1%	RESISTOR 1/4W 1%	RSM1/4FK21,5
27	2	R82,R83	24K9 1%	RESISTOR 1/4W 1%	RSM1/4FK24,9
28	2	R15,R31	33K	RESISTOR 1/4W 5%	RSC1/4JK0033
29	1	R89	40K2 1%	RESISTOR 1/4W 1%	RSM1/4FK40,2
30	1	R91	47K	RESISTOR 1/4W 5%	RSC1/4JK0047
31	4	R56,R57, R72,R73	64K9 1%	RESISTOR 1/4W 1%	RSM1/4FK64,9
32	4	R55,R58, R71,R74	75K0 1%	RESISTOR 1/4W 1%	RSM1/4FK75,0
33	1	R50	100K	RESISTOR 1/4W 5%	RSC1/4JK0100
34	4	R54,R59, R70,R75	115K 1%	RESISTOR 1/4W 1%	RSM1/4FK0115
35	2	R43,R61	150K	RESISTOR 1/4W 5%	RSC1/4JK0150
36	4	R53,R60, R69,R76	324K 1%	RESISTOR 1/4W 1%	RSM1/4FK0324
37	3	R93,R95, R97	470K	RESISTOR 1/4W 5%	RSC1/4JK0470
38	2	R6,R22	1M	RESISTOR 1/4W 5%	RSC1/4JM0001
39	1	P5	TC1K	TRIM.REG.VERT. CERMET	RVTCERVK0001
40	2	P3,P6	TC20K	TRIM.REG.VERT. CERMET	RVTVERVK0020
41	3	P7,P8,P9	TC50K	TRIM.REG.VERT. CERMET	RVTCERVK0050
42	2	P1,P2	M20K	TRIMMER MULTIGIRI	RVTMULAK0020
43	1	P4	TM5K	TRIMM.MULT.REG. VERT.	RVTMULVK0005
44	1	CV1	T8pF	TRIMMER CAPACITOR	CVC080CK600
45	1	C14	8p2	CERAMIC CAPACITOR NP0	CKM8,2BJ600C
46	1	C23	27pF	CERAMIC CAPACITOR NP0	CKM270BJ600C
47	3	C13,C21, C25	47pF	CERAMIC CAPACITOR NP0	CKM470BJ600C
48	2	C36,C37	68pF	CERAMIC CAPACITOR NP0	CKM680BJ600C
49	1	C27	100pFP 1%	POLIESTER CAPACITOR 1%	CPE101BF63

Internal Stereo Coder				Bill Of Materials	Page 3
Item	Quantity	Reference	Part	Description	Part Order Code
50	2	C18,C19	150pFP 1%	POLIELSTER CAPACITOR 1%	CPE151BF63
51	3	C16,C24, C26	1nFP 1%	POLIELSTER CAPACITOR 1%	CPE102BF63
52	1	C22	1n5FP 1%	POLIELSTER CAPACITOR 1%	CPE152BF63
53	2	C7,C9	2n2P 1%	POLIELSTER CAPACITOR	CPE222BF63
54	1	C17	2N7P 1%	POLIELSTER CAPACITOR 1%	CPE272BF63
55	2	C8,C10	3N3P 1%	POLIELSTER CAPACITOR 1%	CPE332BF101
56	4	C15,C20, C29,C30	0.1uF	CERAMIC CAPACITOR	CKM104BK600P
57	1	C35	0.47uF	POLIELSTER CAPACITOR	CPE474EK101
58	3	C31,C32, C33	2.2uF	ELECTROLYTIC CAPACITOR	CEA225AM630
59	1	C5	10uF	ELECTROLYTIC CAPACITOR	CEA106AM350
60	7	C1,C2,C3, C4,C6,C11, C12	100uF	ELECTROLYTIC CAPACITOR	CEA107BM350
61	2	C28,C34	220uF	ELECTROLYTIC CAPACITOR	CEA227BM350
62	4	AF1,AF2, AF3,AF4	LPF19K	LOW PASS FILTER 19KHZ	FLP19KHZ
63	2	TP1,TP2	1 P STRIP	STRIP M 1 PIN	CNTSTRIPMCS
64	2	K6,K7	2 P STRIP	STRIP M P 2.54 2 PIN	CNTSTRIPMCS
65	5	K1,K2,K3, K4,K5	3 P STRIP	STRIP M P 2.54 3 PIN	CNTSTRIPMCS
66	1	J2	4 P STRIP	STRIP M P 2.54 4 PIN	CNTSTRIPMCS
67	3	J1,J4,J6	26 P CONN	CONN. M 2*13 P 2.54	CNTMCSFC26P
68	1	XT1	Q9.728MHZ	CRYSTAL	QRZ9,728HC18
69	1	SW1	SW2V6P	COMMUTAT. 2VIE 6POS FE	COMR2V6PCS
70	2	SW2,SW6	SWSPDT-4	COMMUTATORE 4VIE 2POS	COMR4V2PCS
71	2	LD1,LD5	LED-G5	GREEN LED DIODE	LEDVE05
72	3	Q2,Q3,Q4	BC557	PNP TRANSISTOR	TRNBC557
73	1	Q1	MPF4393	JFET SWITCH. N-CHANNEL	TRNMPF4393
74	2	IC18,IC19	LM393	DOUBLE COMPARATOR	CILLM393

Internal Stereo Coder				Bill Of Materials	Page 4
Item	Quantity	Reference	Part	Description	Part Order Code
75	8	IC1,IC2, IC3,IC4, IC9,IC10, IC15,IC16	LF353	DOUBLE OP. AMP.	CILLF353
76	3	IC5,IC6, IC17	LF356	JPFET IN. OP. AMPLIFIER	CILLF356
77	2	IC8,IC11	4015	SHIFT REGISTER	CID4015
78	4	IC12,IC13, IC14,IC20	4053	TRIPLE 2 CH ANAL. MULT.	CID4053
79	1	IC7	4060	CMOS BIN DIVIDER	CID4060
80	3	R102,R103, R104	WIRE	COLLEGAMENTO A FILO	FILO

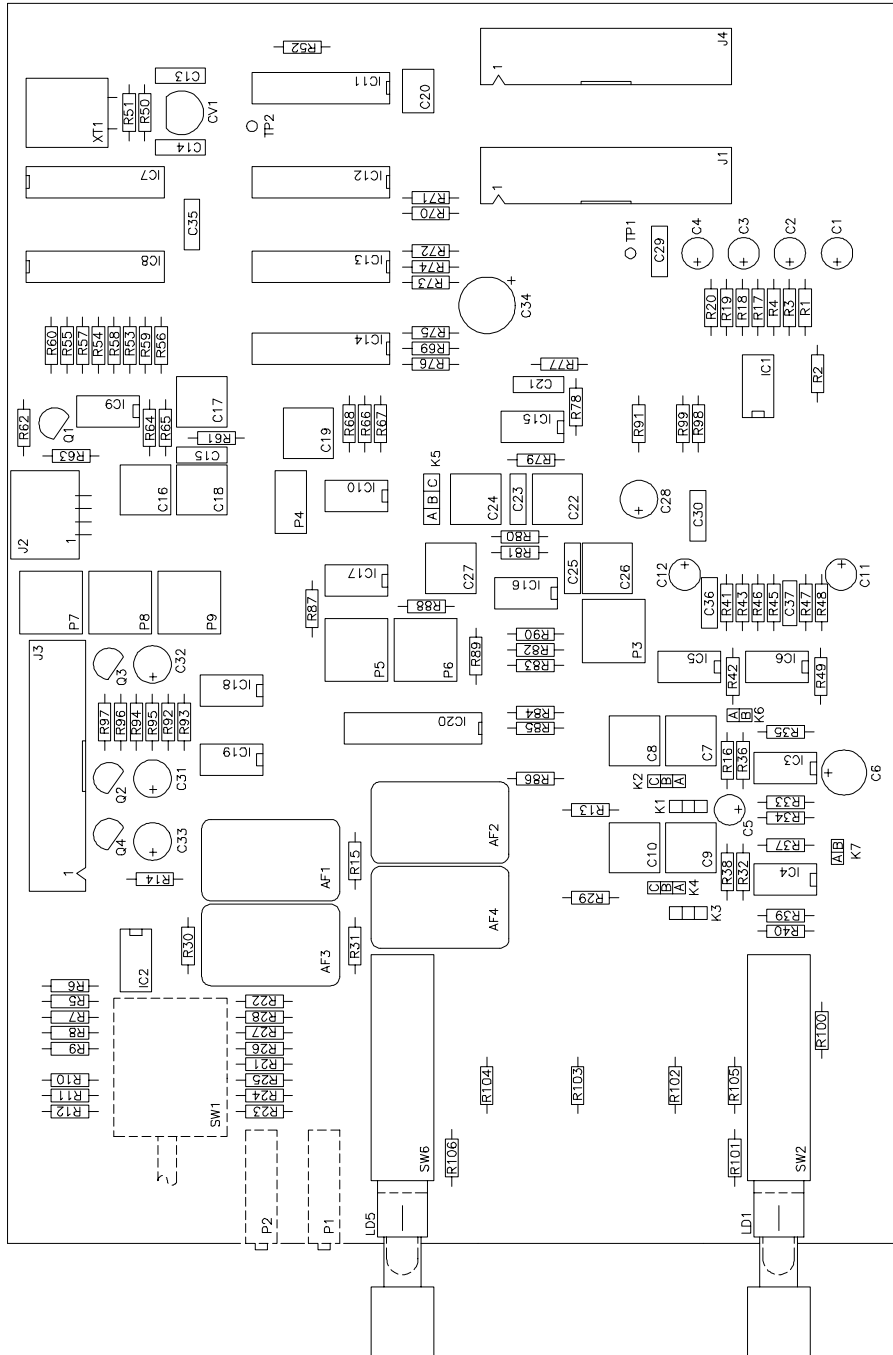

 R.V.R. ELETTRONICA	DENOMINAZIONE Stereo Coder Card Component Layout / Piano di Montaggio
	DISPOSITIVO PTRL-NV/S3 (Aural STL Stereo Transmitter)
	DISEGNATO D'Alessio D. II
SEMILAVORATO	DISEGNATO D'Alessio D. II
MATERIALE	SCALA
TRATTAMENTO	TAVOLA n 1 di 1

© Copyright 1994
First Edition - June '95
Created By D'Alessio D. & Morotti M.

R.V.R. Elettronica S.r.l. (Bo)
Via del Fonditore 2/2c - 40138 - Bologna (Italy)
Telephone: +39 - 51 - 6010506
Fax: +39 - 51 - 6011104

Printed and bound in Italy. All rights reserved. No part of this manual may be reproduced or utilized in any form or by any means, electronic or mechanical, including photocopying, recording, or by any information storage and retrieval system, without permission in writing from the publisher.

APPENDIX

Description	RVR Code Pages	Vers.	
Power Supply	PSSW-PTNV	0.1	6
C.P.U. section	CPU-NV	0.1	10
Stereo coder card	CSSDC30A0003	0.1	6
Trimmer & Settings	CSSDC30A0003	0.1	2

Pagina lasciata intenzionalmente in bianco

PTX30 PTX30UHT

REGOLAZIONE
BIBIETTA

SCHEMA IL
TRIMMER
INTERNA
PER REG. AUREA
DEL TUNING

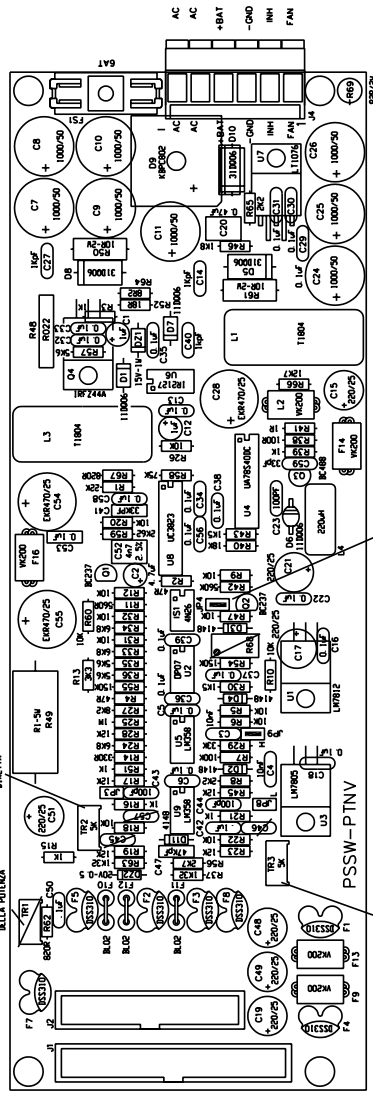

INCL. IL
POT. CELLO PER
P-PASSANDO

PTNV PTRL-NV

REGOLAZIONE
RIFLESSA
NORMALE IL

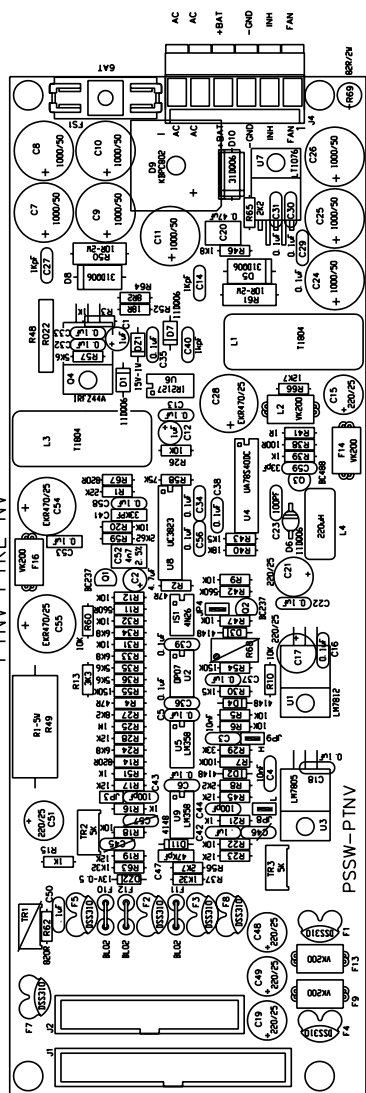

		Nome Progetto: PTRLNV	Pagina: 1 di 1	Size: A3
Autore: BERTI J.	Data: 10/12/01	Codice Progetto: /	Nome Parte: ALIMENTAZIONE PTX30PTX30UHT PTRL-NV PTVN	
Nome PC in Rete: \JAACK\	Revisione: 1.0	Autorizzazione: /	Codice: PSSMPTX30	
File/Caricis: MANUALE\APPENDIX\PTRL_NV\LA\MULL.DWG	Trattamento: /	Materiale: /	Profilo: /	

Item	Q.ty	Reference	Part
1	2	C1, C12	CT1/35
2	1	C2	4.7UF
3	2	C3, C4	CM10NF
4	20	C5, C6, C13, C16, C18, C22, C29, C30, C31, C32, C33, C34, C35, C36, C37, C38, C39, C50, C56, C58	CM.1UF
5	8	C7, C8, C9, C10, C11, C24, C25, C26	1000/50
6	3	C14, C27, C40	CD1KPF
7	6	C15, C17, C19, C21, C48, C49	220/25
8	1	C20	CP.47UF
9	3	C23, C43, C44	CM100PF
10	3	C28, C54, C55	EKR470/25
11	1	C41	CP33KPF
12	1	C42	CD.1UF
13	3	C45, C46, C57	CD*
14	1	C47	CP47KPF
15	1	C51	220/40
16	1	C52	4N7UF
17	1	C53	CP.1UF
18	1	C59	33PF
19	1	DZ1	15V/1W
20	1	DZ2	20V-0.5W
21	3	D1, D6, D7	11DQ06
22	4	D2, D3, D4, D11	1N4148
23	3	D5, D8, D10	31DQ06
24	1	D9	KBPC802
25	1	FS1	6AT

26	7	F1, F2, F3, F4, F5, F7, F8	DSS-310
27	5	L2, F9, F13, F14, F16	WK200
28	3	F10, F11, F12	BL02
29	1	IS1	4N26
30	3	JP3, JP8, JP9	STRIP2
31	1	JP4	KRA6
32	1	JP4	JUMPER
33	1	J1	CON34A
34	1	J2	CON26A
35	2	L1, L3	T1804
36	1	L4	220UH
37	2	Q1, Q2	BC237
38	1	Q3	BC488
39	1	Q4	IRFZ44A
40	1	R1	22K
41	1	R2	47R
42	7	R3, R4, R15, R16, R21, R39, R51	1K
43	14	R5, R6, R9, R10, R12, R18, R20, R22, R26, R31, R32, R47, R57, R60	10K
44	3	R7, R54, R55	100K
45	2	R8, R65	2K2
46	1	R11	560R
47	1	R13	3K3
48	1	R14	330R
49	5	R17, R19, R23, R28, R45	12K
50	3	R24, R33, R34	6K8
51	1	R25	1M
52	1	R27	8K2
53	1	R29	33K

54	2	R30, R43	1K5
55	2	R35, R36	5K6
56	2	R37, R63	1K32
57	1	R38	100R
58	1	R40	18K
59	1	R41	1R0
60	1	R42	560K
61	1	R46	1K8
62	1	R48	MIA22UH
63	1	R49	R1/5W
64	2	R50, R61	10R/1W
65	1	R52	18R
66	1	R56	2K7
67	1	R58	75K
68	1	R59	2K62
69	2	R62, R67	820R
70	1	R64	8R2
71	1	R66	12K7
72	1	R68	87W20K
73	1	R69	82R/2W
74	2	TR1, TR3	HC5
75	1	TR2	HC5K
76	1	U1	LM7812
77	1	U2	OP07
78	1	U3	LM7805
79	1	U4	UA78S40DC
80	2	U5, U9	LM358
81	1	U6	IR2127
82	1	U7	LT1076CT
83	1	U8	UC3823
84	1	C60	180nF

Pagina lasciata intenzionalmente in bianco
This page was intentionally left blank

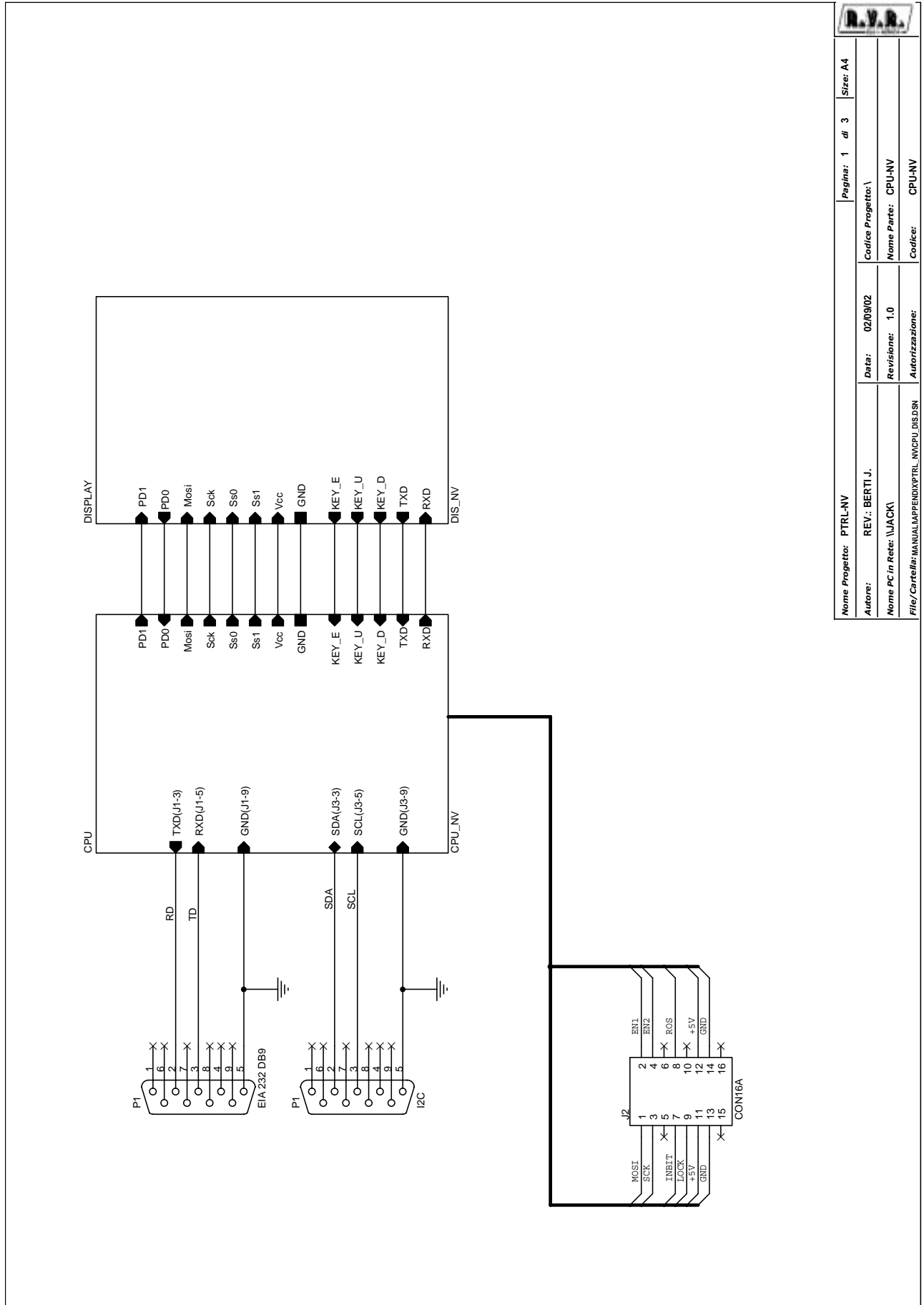

		Pagina: 1 di 3	Size: A4
Nome Progetto: PTRL-NV	Data: 02/09/02	Codice Progetto: \	
Autore: REV. BERTI J.	Revisione: 1.0	Nome Parte: CPU-NV	
Nome PC in Rete: \JACK\	Autorizzazione:	Codice: CPU-NV	
File/ Cartella: \MANUAL\APPENDIX\PTRL_NV\CPU_DISPLAY			

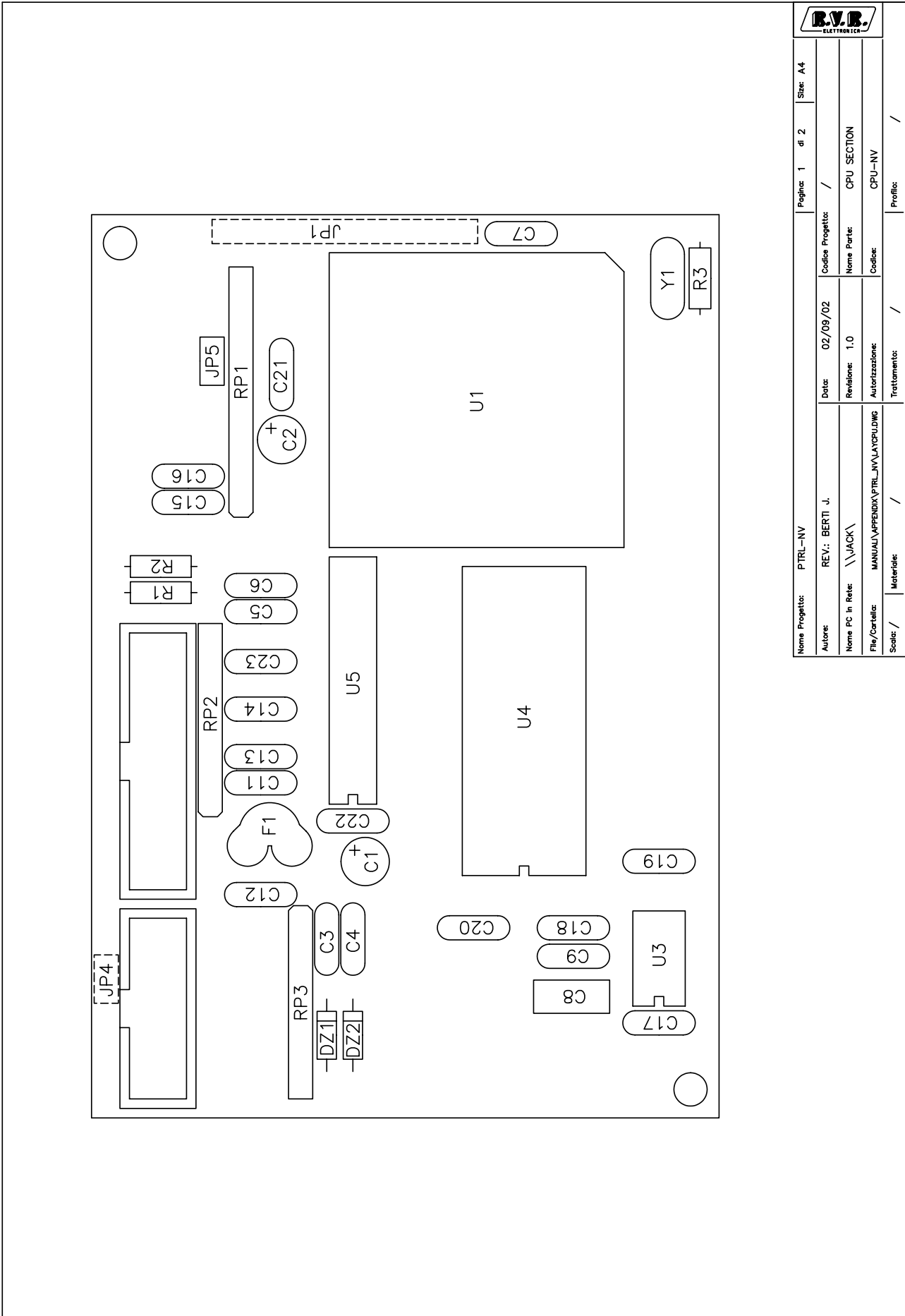

Nome Progetto: PTRL-NV		Pagina: 1	di 2	Size: A4
Autore: BERTI J.	REVISIONI: REV. 02/09/02	Codice Progetto: /		
Nome PC in Rete: \\JACK\	Revisione: 1.0	Nome Parte: CPU SECTION		
File/Caricella: MANUALE\APPENDIX\PTRL_NV\LAY\CPU.DWG	Autorizzazione:	Codice: CPU-NV		
Scala: /	Materiale: /	Trattamento: /		
		Profilo: /		

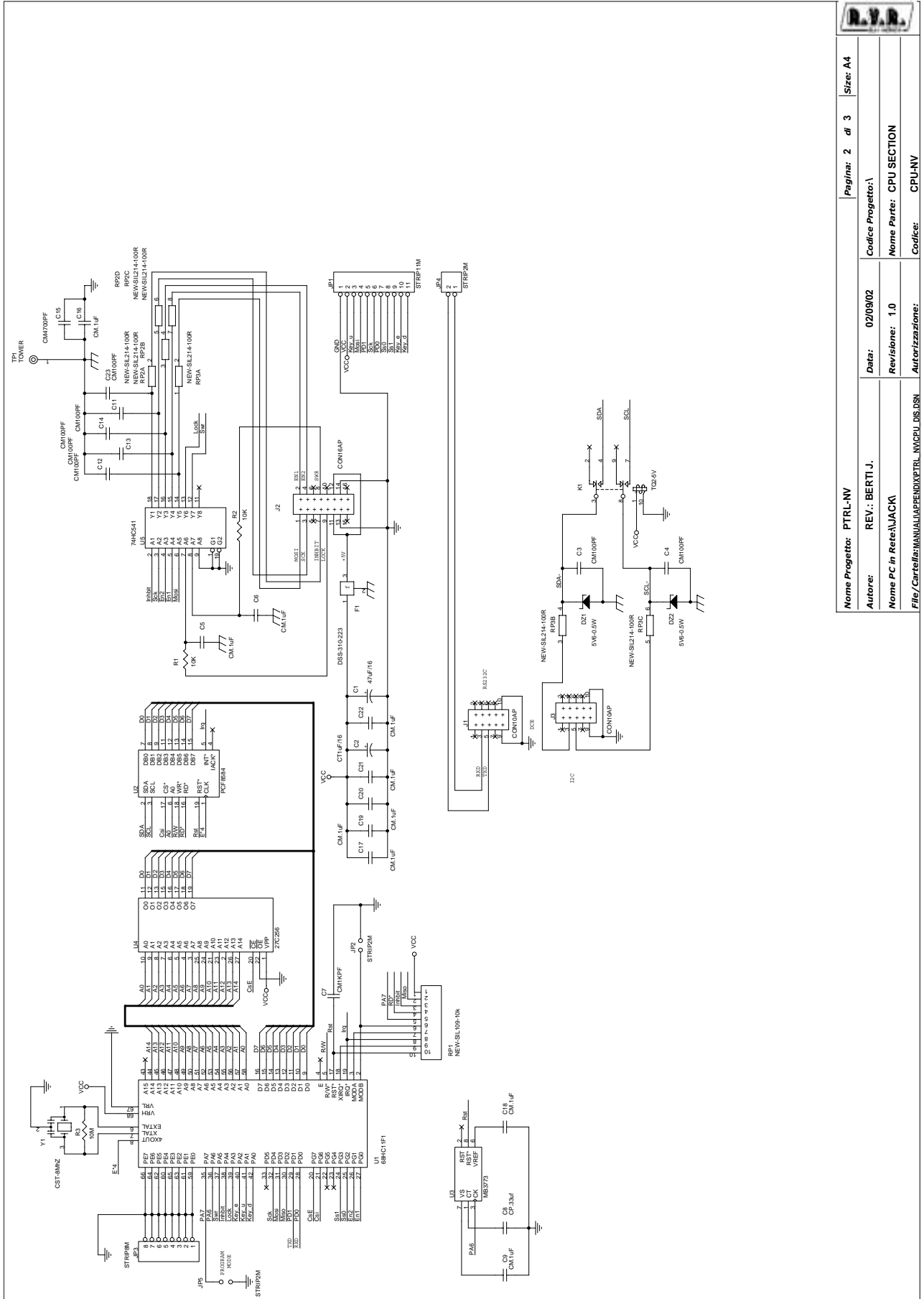

Nome Progetto:	PTRL-NV
Autore:	REV.: BERTI.J.
Nome PC in Rete:	NUACK
File/Carter/Manuali/Appendix/PTRL_NVCPU_US.DSN	
Data:	02/09/02
Revisione:	1.0
Autore:	BERTI.J.
Nome Parte:	CPU SECTION
File/Carter/Manuali/Appendix/PTRL_NVCPU_US.DSN	
Codice:	CPU-NV
Pagina:	2 di 3
Size:	A4

Item	Quantity	Reference	Part
1	1	C1	47UF/16
2	1	C2	CT1UF/16
3	7	C3, C4, C11, C12, C13, C14, C23	CM100PF
4	10	C5, C6, C9, C16, C17, C18, C19, C20, C21, C22	CM.1UF
5	1	C7	CM1KPF
6	1	C8	CP.33UF
7	1	C15	CM4700PF
8	2	DZ1, DZ2	5V6-0.5W
9	1	F1	DSS-310-223
10	1	JP1	STRIP11M
11	3	JP2, JP4, JP5	STRIP2M
12	1	JP3	STRIP8M
13	2	J1, J3	CON10AP
14	1	J2	CON16AP
15	1	K1	TQ2-5V
16	1	RP1	NEW-SIL109-10K
17	2	RP2, RP3	NEW-SIL214-100R
18	2	R1, R2	10K
19	1	R3	10M
20	1	TP1	TOWER
21	1	U1	68HC11F1
22	1	U2	PCF8584
23	1	U3	MB3773
24	1	U4	27C256
25	1	U5	74HC541
26	1	Y1	CST-8MHZ

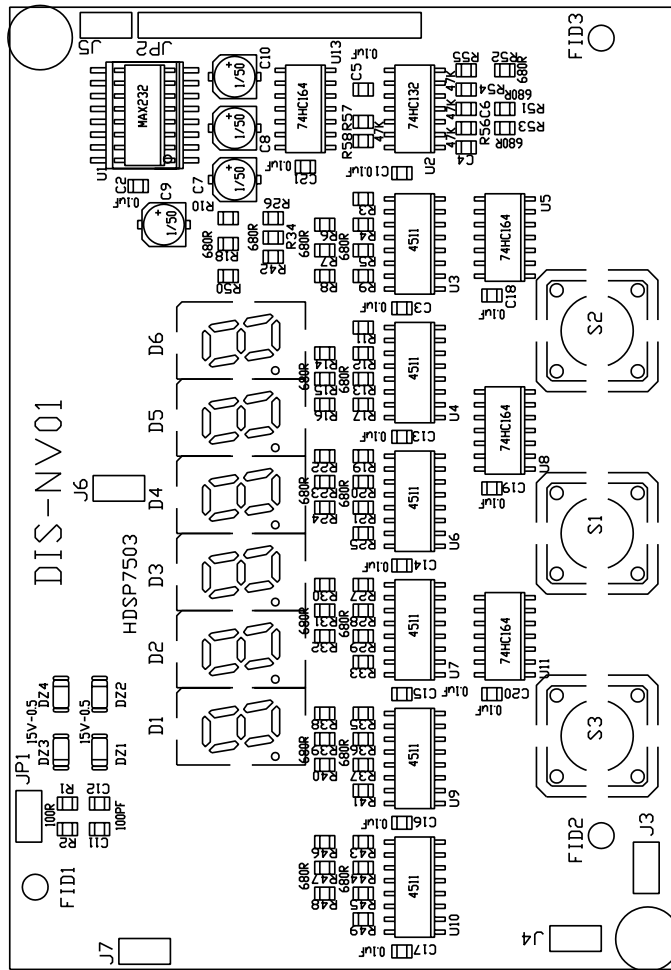

B.V.B. ELETTRONICA		Pagine: 1	di 1	Size: A4
Nome Progetto:	PTRL NV	Data:	12/09/02	Codice Progettore: /
Autore:	REV.: BERTI J.	Revisione:	1.0	Nome Parte: DISPLAY CPU VERSIONE 2
Nome PC in Rete:	\\JACK\	Autore:		Codice: DIS-NV01
File/Cartella:	MANUAL\APPENDIX\PTRL_NV\DIS2.MNT.DWG	Trattamento:	/	Profilo: /
Scala:	1:1			

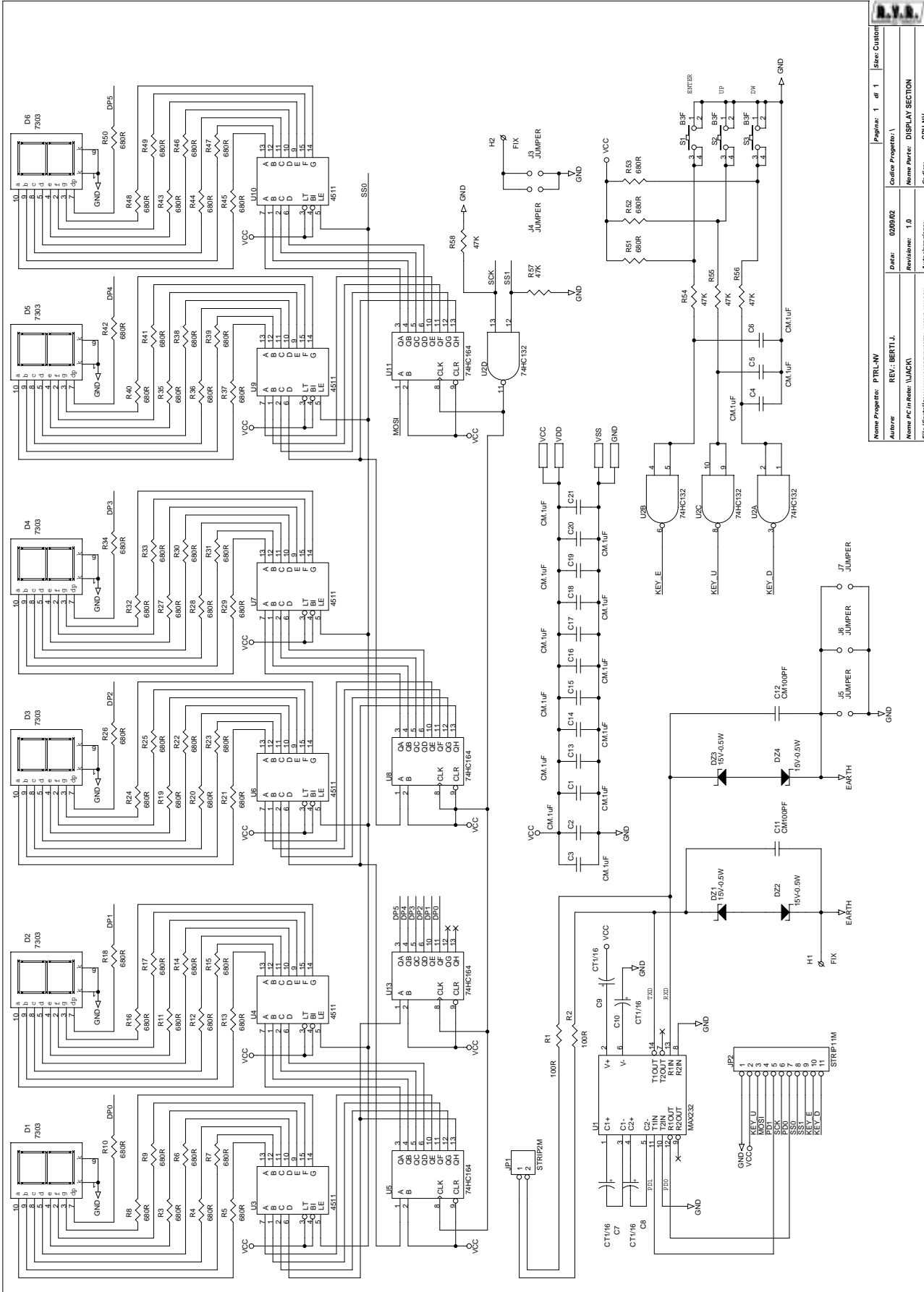

Nome Progetto: PTRL-NV	Revisione: 1	Autore: BERTI J.	Progetto: \	Page: 1 of 1	See Custom
Autore: REV: BERTI J.	Revisione: 1.0	Autore: BERTI J.	Progetto: \		
Nome PC in Rete: UACVA			Nome Periferico: DISPLAY SECTION		
File/Caratteristiche: MANUALE PTRL-NV/S3			Autore/Revisione: CPU-NV		

DISPLAY SECTION Bill Of Materials

Page1

Item	Q.ty	Reference	Part
1	15	C1, C2, C3, C4, C5, C6, C13, C14, C15, C16, C17, C18, C19, C20, C21	CM.1uF
2	4	C7, C8, C9, C10	CT1/16
3	2	C11, C12	CM100PF
4	4	DZ1, DZ2, DZ3, DZ4	15V-0.5W
5	6	D1, D2, D3, D4, D5, D6	7303
6	2	H2, H1	FIX
7	1	JP1	STRIP2M
8	1	JP2	STRIP11M
9	5	J3, J4, J5, J6, J7	JUMPER
10	2	R1, R2	100R
11	51	R3, R4, R5, R6, R7, R8, R9, R10, R11, R12, R13, R14, R15, R16, R17, R18, R19, R20, R21, R22, R23, R24, R25, R26, R27, R28, R29, R30, R31, R32, R33, R34, R35, R36, R37, R38, R39, R40, R41, R42, R43, R44, R45, R46, R47, R48, R49, R50, R51, R52, R53	680R
12	5	R54, R55, R56, R57, R58	47K
13	3	S1, S2, S3	B3F
14	1	U1	MAX232
15	1	U2	74HC132
16	6	U3, U4, U6, U7, U9, U10	4511
17	4	U5, U8, U11, U13	74HC164

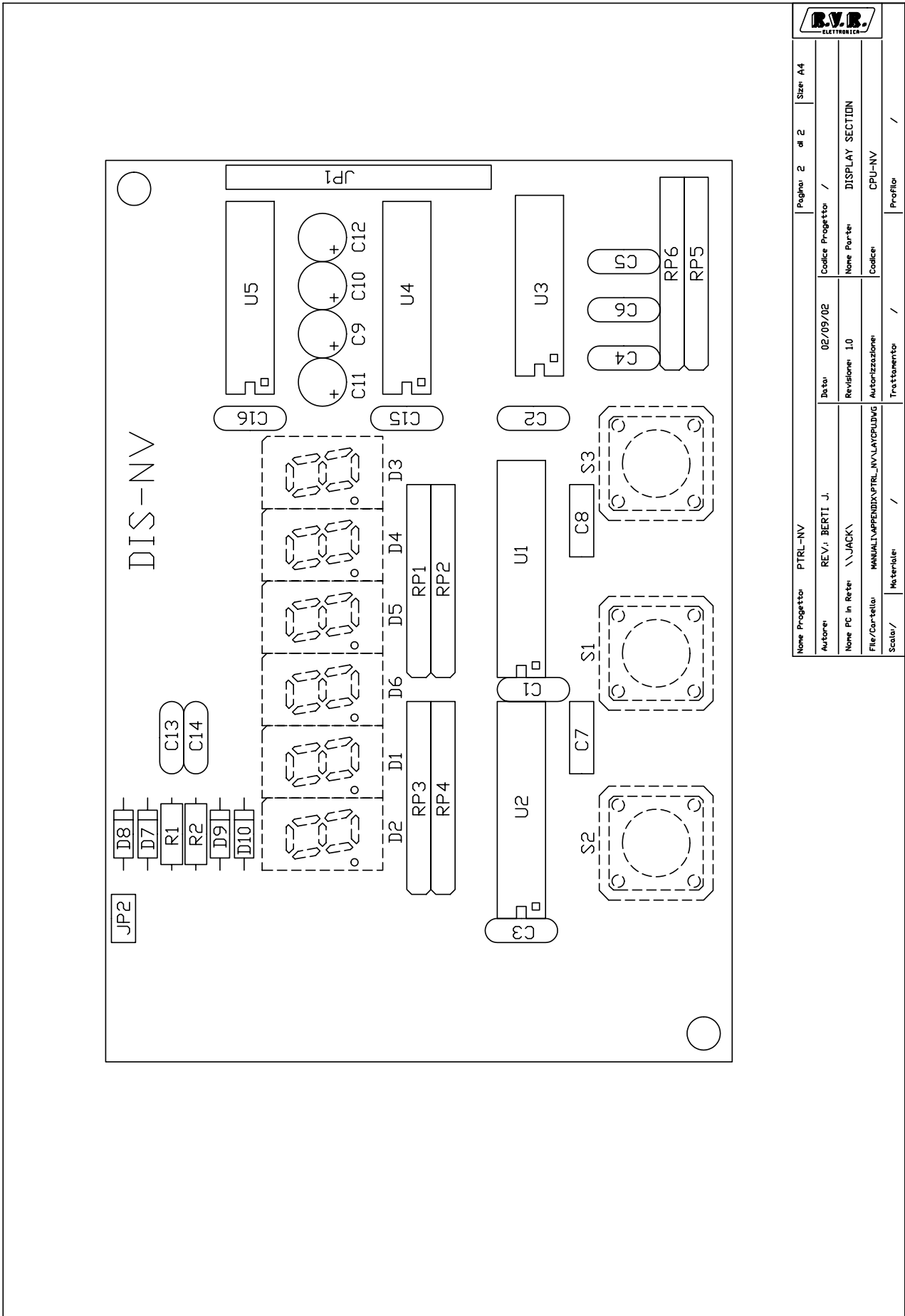

Nome Progettista: PTRL-NV		Pagina: 2 di 2		Size: A4
Autore: REV.: BERTI J.	Data: 02/09/02	Codice Progettista: /		
Nome PC in Rete: \JACK\	Revisione: 1.0	Nome Parte: DISPLAY SECTION		
File/Cartella: MANUALE\APPENDIX\PTRL_NV\LAY\CPUBLDG	Autonizzazione:	Codice: CPU-NV		
Scala: /	Materiale: /	Trattamento: /		Profilo: /

Versione precedente, solo per riferimento

Former version, for reference only

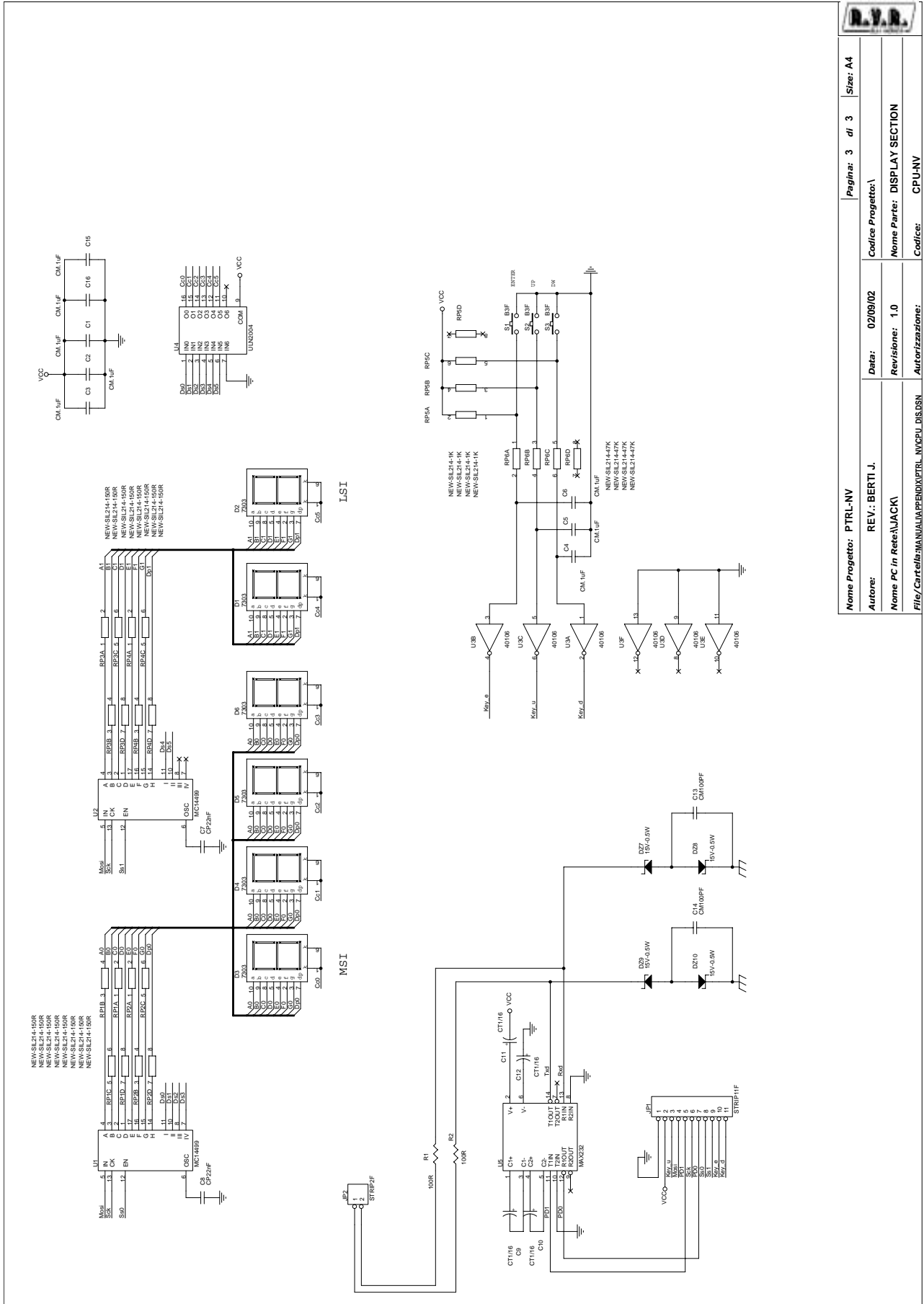

Nome Progetto: PTRL-NV	Pagina: 3 di 3
Autore: REV.: BERTI J.	Data: 02/09/02
Nome PC in Rete: \JACK	Revisione: 1.0
File/Cartella: MANUALE\APPENDIX\PTRL_NV\PCU_DIS.DSN	Autore/Revisione: BERTI J. / 1.0
	Codice Progetto: \
	Nome Parte: DISPLAY SECTION
	Codice: CPU-NV
	Dimensione: A4

Versione precedente, solo per riferimento
Former version, for reference only

Item	Quantity	Reference	Part
1	8	C1, C2, C3, C4, C5, C6, C15, C16	CM.1UF
2	2	C7, C8	CP22NF
3	4	C9, C10, C11, C12	CT1/16
4	2	C13, C14	CM100PF
5	4	DZ7, DZ8, DZ9, DZ10	15V-0.5W
6	6	D1, D2, D3, D4, D5, D6	7303
7	1	JP1	STRIP11F
8	1	JP2	STRIP2F
9	4	RP1, RP2, RP3, RP4	NEW-SIL214-150R
10	1	RP5	NEW-SIL214-1K
11	1	RP6	NEW-SIL214-47K
12	2	R1, R2	100R
13	3	S1, S2, S3	B3F
14	2	U1, U2	MC14499
15	1	U3	40106
16	1	U4	ULN2004
17	1	U5	MAX232

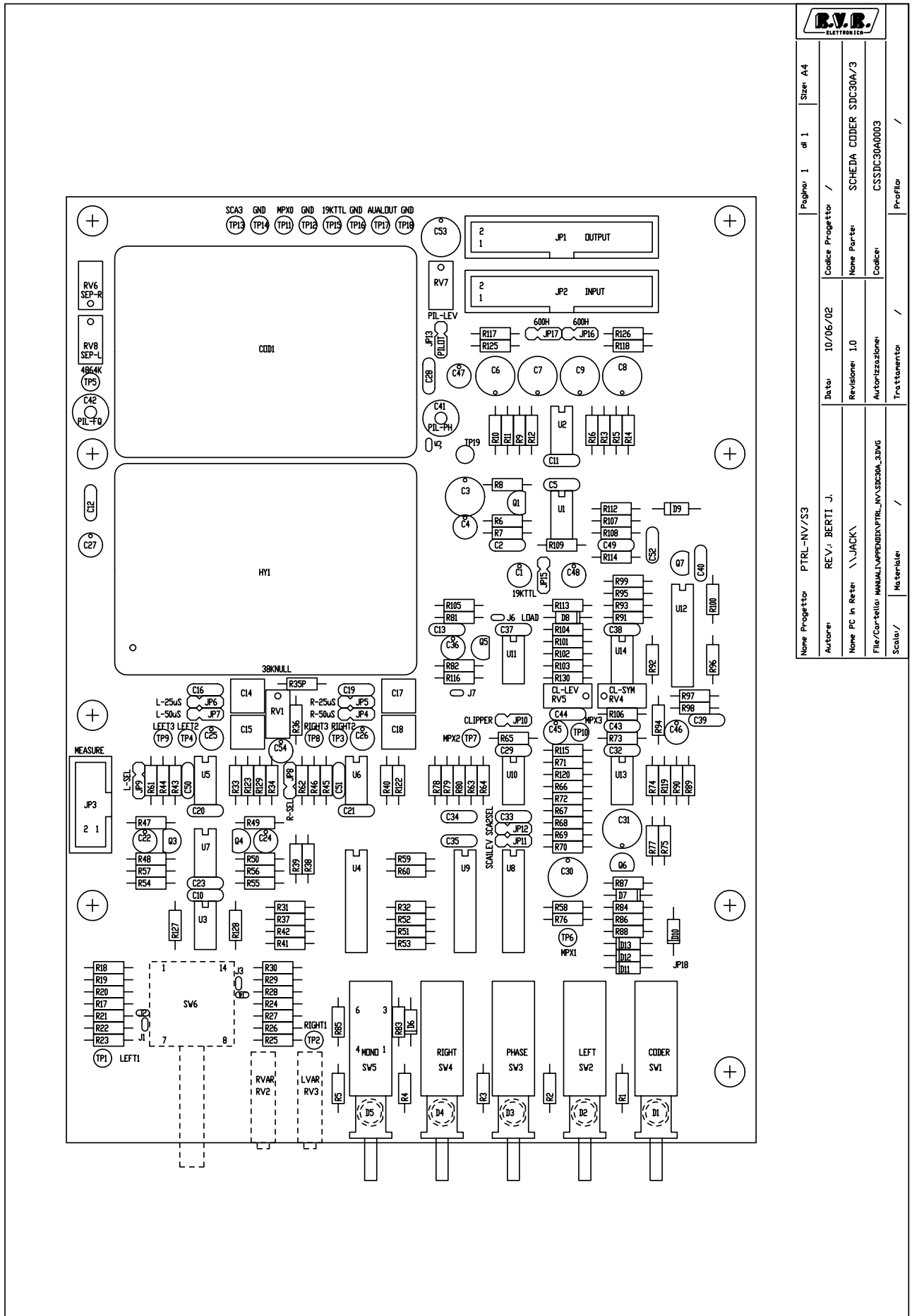

		Nome Progetto	PTRL-NV/S3	Page	1 di 1	Size	A4
Autore	REV: BERTI J.	Coilce Progettato	/				
Nome PC in Rete	\\JACK	Revisione	1.0				
File/Cartello	MANUALI\PEP\BIB\PTL-NV\SSDC30A_3.DWG	Nome Parte	SCHEDA CODER SDC30A/3				
Scala	/	Autore	CSSDC30A003				
		Trattamento	/				
		Profilo	/				

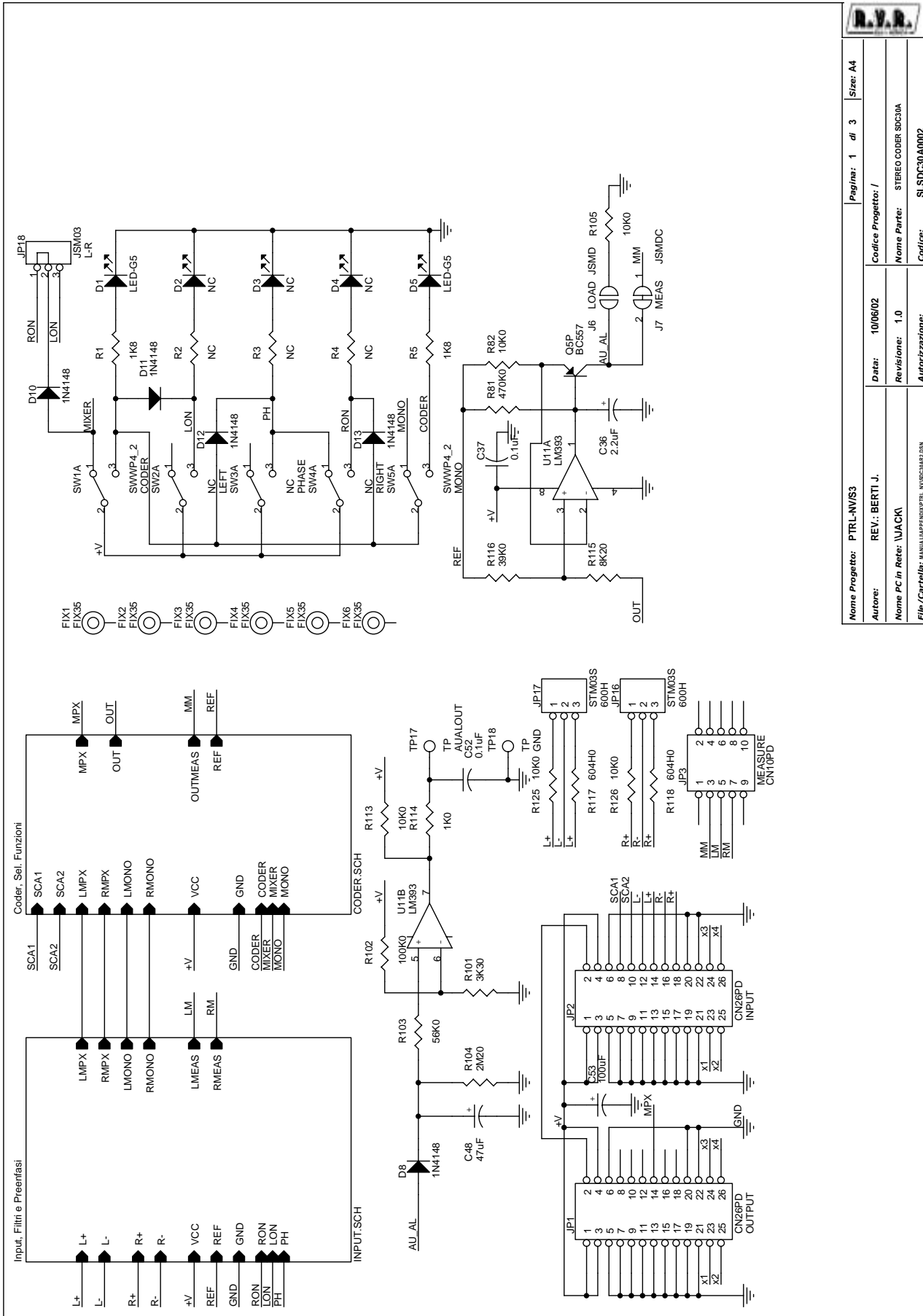

Nome Progetto: PTRL-NV/S3		Pagina: 1 di 3		Size: A4	
Autore: REV.: BERTI J.		Data: 10/06/02		Codice Progetto: I	
Nome PC in Rete: UACKI		Revisione: 1.0		Nome Parts: STEREO CODER SDC30A	
File/Caratteri: MANUALE PTRL_NV/S3.DSN		Autorizzazioni:		Codice: SLSDC30A0002	

SW2, RV2, RV3 VANO KORRATI LATO SQUADRISTE
 J1, J2, J3 e J4 vanno fatti lato componenti

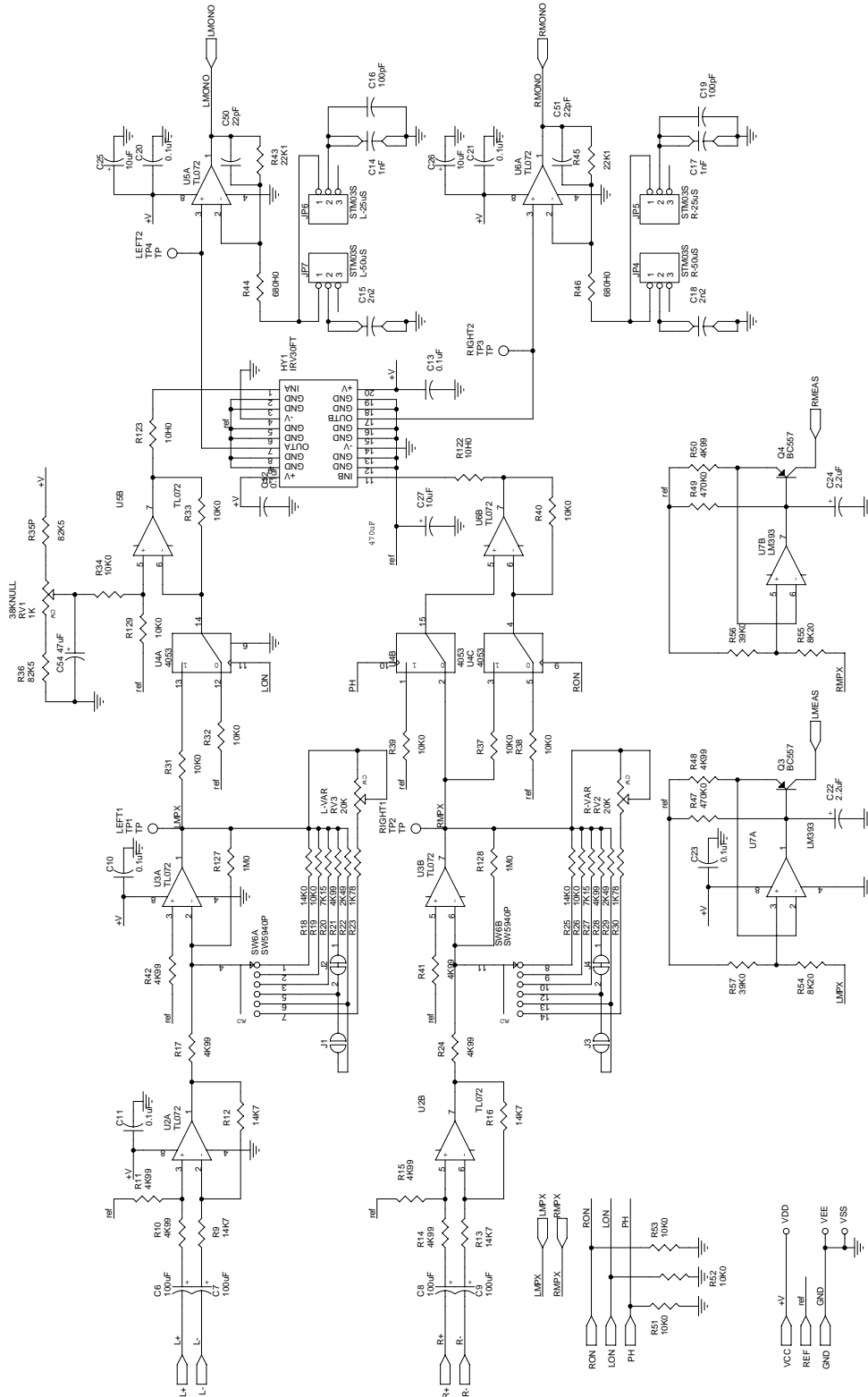

Nome Progetto:	PTRL-NV/S3	Pagina:	2	di	3	Inte:	A3	
Autore:	REV.: BERTI J.	Data:	10/08/02				Codice Progetto:	/
Nome PC in Rete:	WACKI	Revisione:	1.0				Nome Percorso:	INVIT/FILE/PROIEZIONI/S3
File/Caricab:	MANUALI/PROIEZIONI/S3	Autore/Revisione:	S3/DC30A002				Contatto:	

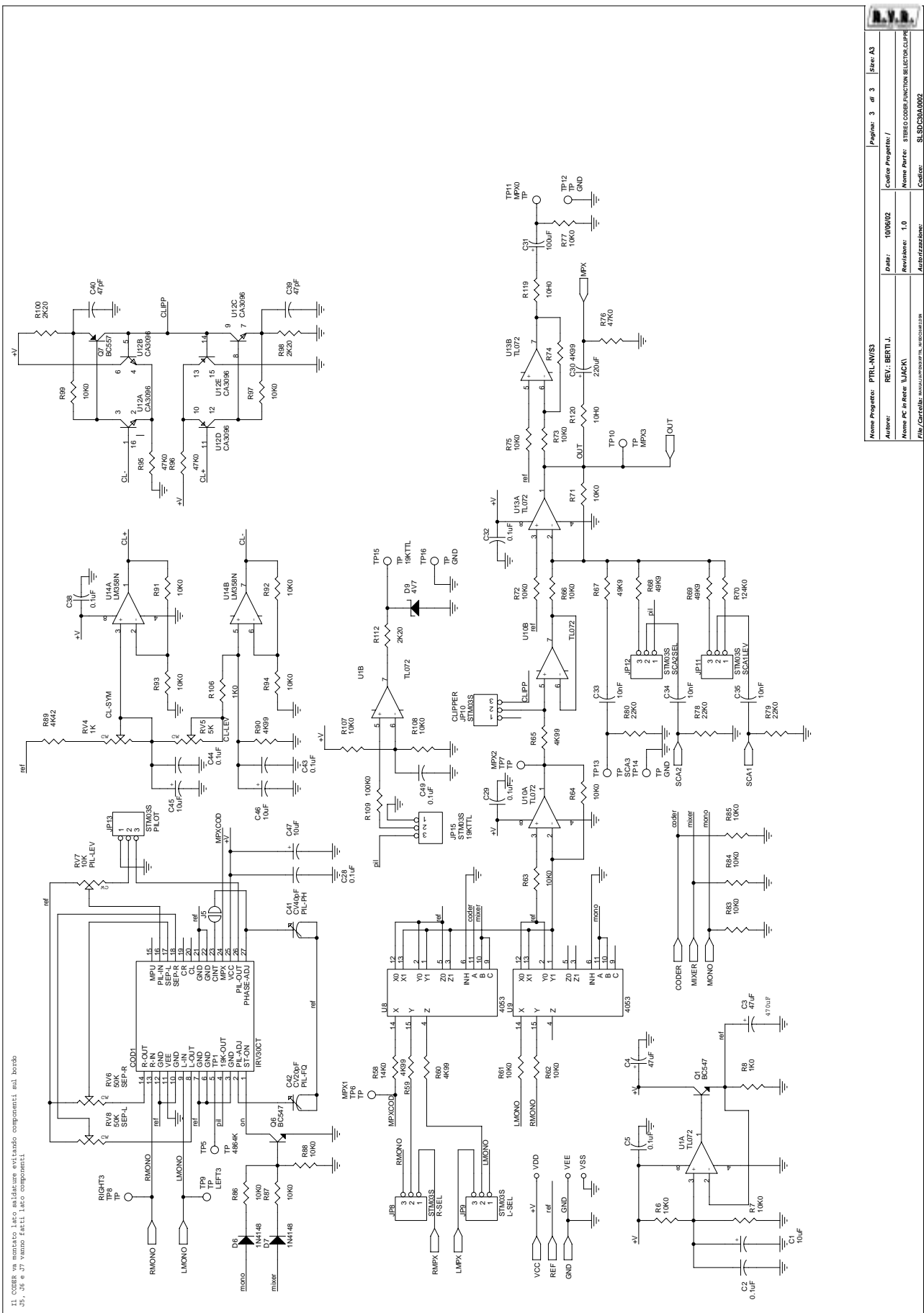

II. CODER va montato lato antistatura evitando componenti sul bordo
05, 06 e 07 vanno fatti lato componenti

R.V.A. ELETTRONICA	
Nome Progetto: PTRL-NV/S3	Pagina: 3 di 3
Autore: REV: BERTI J.	Nome Progetto: /
Nome PC in Rete: BLACK1	Data: 10/06/02
File/Carrello: MANUALE/PRODOTTORE/PRODOTTORE	Revisione: 1.0
	Autore: STIBILO CODE/FUNCTION SELECTOR CLIPPER
	Codice: SLS3CDA002

SLSDC30A002 Bill Of Materials Page1

Item	Quantity	Reference	Part
1	1	COD1	IRV30CT
2	7	C1, C25, C26, C27, C45, C46, C47	10uF
3	18	C2, C5, C10, C11, C12, C13, C20, C21, C23, C28, C29, C32, C37, C38, C43, C44, C49, C52	0.1uF
4	4	C3, C4, C48, C54	47uF
5	6	C6, C7, C8, C9, C31, C53	100uF
6	2	C17, C14	1nF
7	2	C18, C15	2n2
8	2	C19, C16	100pF
9	3	C22, C24, C36	2.2uF
10	1	C30	220uF
11	3	C33, C34, C35	10nF
12	2	C39, C40	47pF
13	1	C41	CV40pF
14	1	C42	CV20pF
15	2	C50, C51	22pF
16	2	D1, D5	LED-G5
17	9	SW2, R2, D2, SW3, R3, D3, SW4, R4, D4	NC
18	7	D6, D7, D8, D10, D11, D12, D13	1N4148
19	1	D9	4V7
20	6	FIX1, FIX2, FIX3, FIX4, FIX5, FIX6	FIX35
21	1	HY1	IRV30FT
22	2	JP1, JP2	CN26PD
23	1	JP3	CN10PD
24	13	JP4, JP5, JP6, JP7, JP8, JP9, JP10, JP11, JP12, JP13, JP15, JP16, JP17	STM03S
25	1	JP18	JSM03
26	4	J1, J3, J5, J6	JSMDC
27	3	J2, J4, J7	JSMDC
28	2	Q1, Q6	BC547
29	4	Q3, Q4, Q5P, Q7	BC557
30	2	RV4, RV1	1K
31	2	RV2, RV3	20K
32	1	RV5	5K
33	2	RV8, RV6	50K
34	1	RV7	10K
35	2	R1, R5	1K8
36	45	R6, R7, R19, R26, R31, R32, R33, R34, R37, R38, R39, R40, R51, R52, R53, R61, R62, R63, R64, R66, R71, R72, R73, R75, R77, R82, R83, R84, R85, R86, R87, R88, R91, R92, R93, R94, R97, R99, R105, R107, R108, R113, R125, R126, R129	10K0
37	3	R8, R106, R114	1K0
38	4	R9, R12, R13, R16	14K7
39	17	R10, R11, R14, R15, R17, R21, R24, R28, R41, R42, R48, R50, R59, R60, R65, R74, R90	4K99

40	3	R18, R25, R58	14K0
41	2	R27, R20	7K15
42	2	R29, R22	2K49
43	2	R30, R23	1K78
44	2	R35P, R36	82K5
45	2	R45, R43	22K1
46	2	R46, R44	680H0
47	3	R47, R49, R81	470K0
48	3	R54, R55, R115	8K20
49	3	R56, R57, R116	39K0
50	3	R67, R68, R69	49K9
51	1	R70	124K0
52	3	R76, R95, R96	47K0
53	3	R78, R79, R80	22K0
54	1	R89	4K42
55	3	R98, R100, R112	2K20
56	1	R101	3K30
57	2	R102, R109	100K0
58	1	R103	56K0
59	1	R104	2M20
60	2	R117, R118	604H0
61	4	R119, R120, R122, R123	10H0
62	2	R127, R128	1M0
63	2	SW1, SW5	SWWP4_2
64	1	SW6	SW5940P
65	18	TP1, TP2, TP3, TP4, TP5, TP6, TP7, TP8, TP9, TP10, TP11, TP12, TP13, TP14, TP15, TP16, TP17, TP18	TP
66	7	U1, U2, U3, U5, U6, U10, U13	TL072
67	3	U4, U8, U9	4053
68	2	U11, U7	LM393
69	1	U12	CA3096
70	1	U14	LM358N

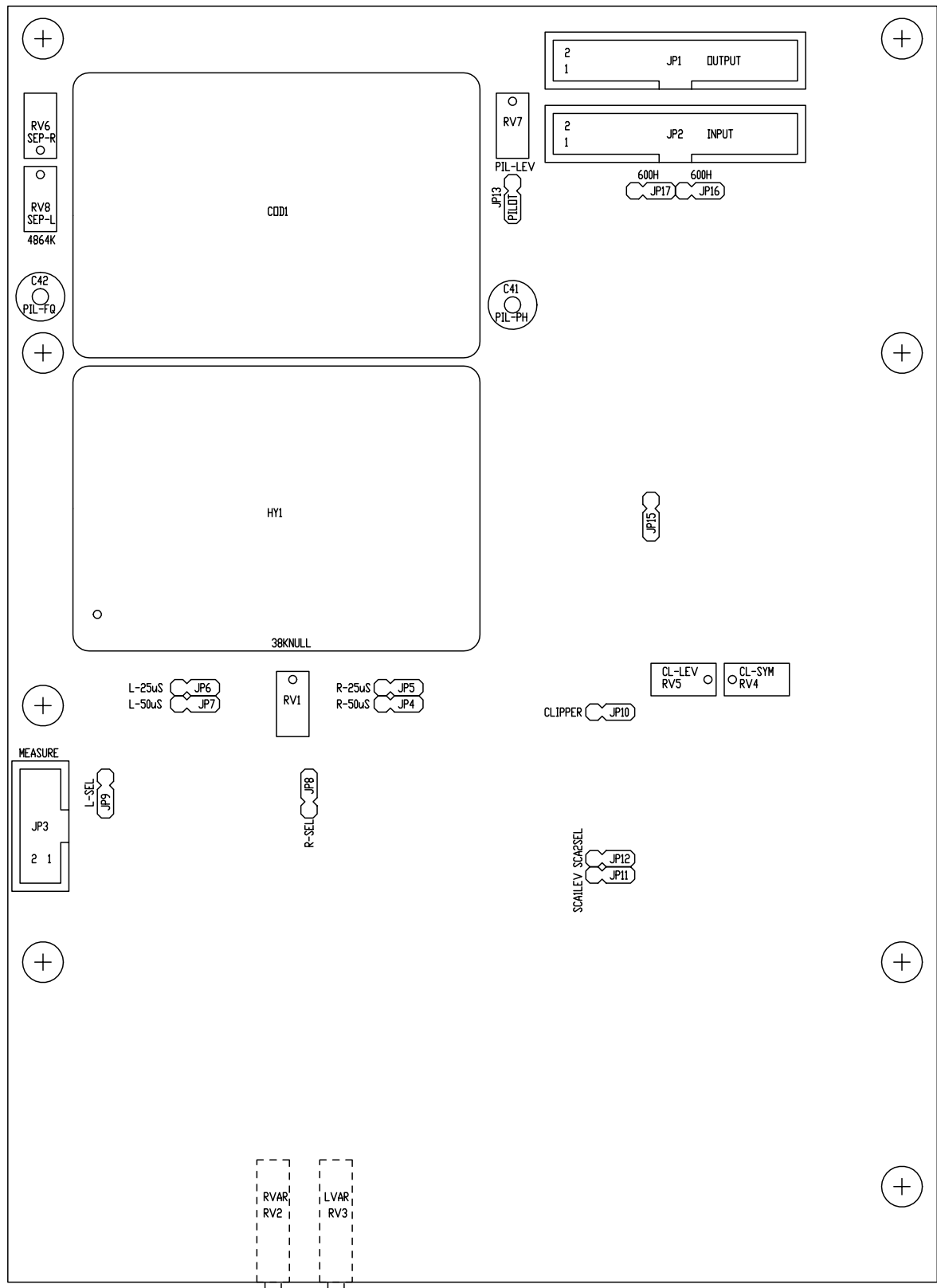

INPUT IMPEDANCE SETTING	
JUMPER JP16 & JP 17	
600 Ohm	10 Kohm
• -	- •
CLIPPER SETTING	
JUMPER JP10	
ON	OFF
- •	• -

RIGHT CHANNEL PREEMPHASIS SETTING					
SETT.	JUMP.	OFF	25µS	50µS	75µS
JP5		• -	- •	• -	- •
JP4		• -	- •	- •	- •
LEFT CHANNEL PREEMPHASIS SETTING					
SETT.	JUMP.	OFF	25µS	50µS	75µS
JP6		• -	- •	• -	- •
JP7		• -	- •	- •	- •

TRIMMER AND COMPENSATOR FUNCTION	
REFERENCE	FUNCTION DESCRIPTION
RV1	38 KHz Suppression
RV2	Right Channel Input Level
RV3	Left Channel Input Level
RV4	Clipper Symmetry
RV5	Clipper Level
RV6	Left Channel Separation
RV7	Pilot Tone Level
RV8	Right Channel Separation
C41	Pilot Phase
C42	Pilot Frequency

Pagina lasciata intenzionalmente in bianco
This page was intentionally left blank