

HC3 LCD

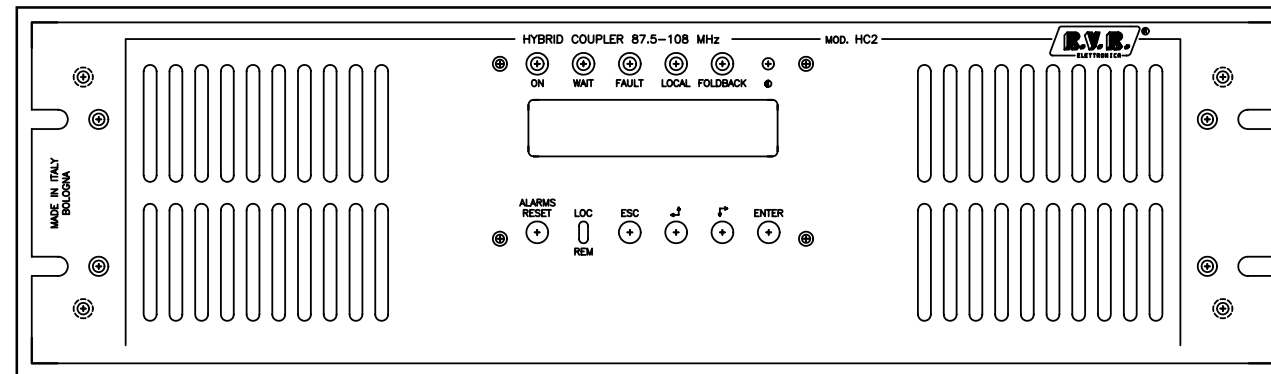

User Manual

Volume 2: Technical Appendix

Appendix A Piani di montaggio, schemi elettrici, liste componenti / *Component layouts, schematics, bills of material*

Questa parte del manuale contiene i dettagli tecnici riguardanti la costruzione delle singole schede componenti il HC3 LCD. L'appendice è composta dalle seguenti sezioni:

This part of the manual contains the technical details about the different boards of the HC3 LCD. This appendix is composed of the following sections:

Description	RVR Code	Vers.	Page
Wiring diagrams		2.0	1
Power Splitter & Ext. Phase Adj.	SLSPLINHC2LC	2.0	3
Power Combiner	CSHYBPWRCL	2.0	5
Unbal Power Card	SLUNBALHC3LC	2.0	8
CPU section	SLPROTPJ-HCL	2.1	10
Remote Card	SLSMT2HC2	2.0	16
EMI Filter	SLADPCNPRTPJ	2.0	18
Power Meter Card	SLPWRMTRHC5	2.0	20
Sonda Termica	SLSONDTERM	2.0	22

Document History

Date	Version	Reason	Author
16/06/03	2.0	First Release in A3 Format	G. De Donno
11/09/03	2.1	Minor Corrections	J. Berti

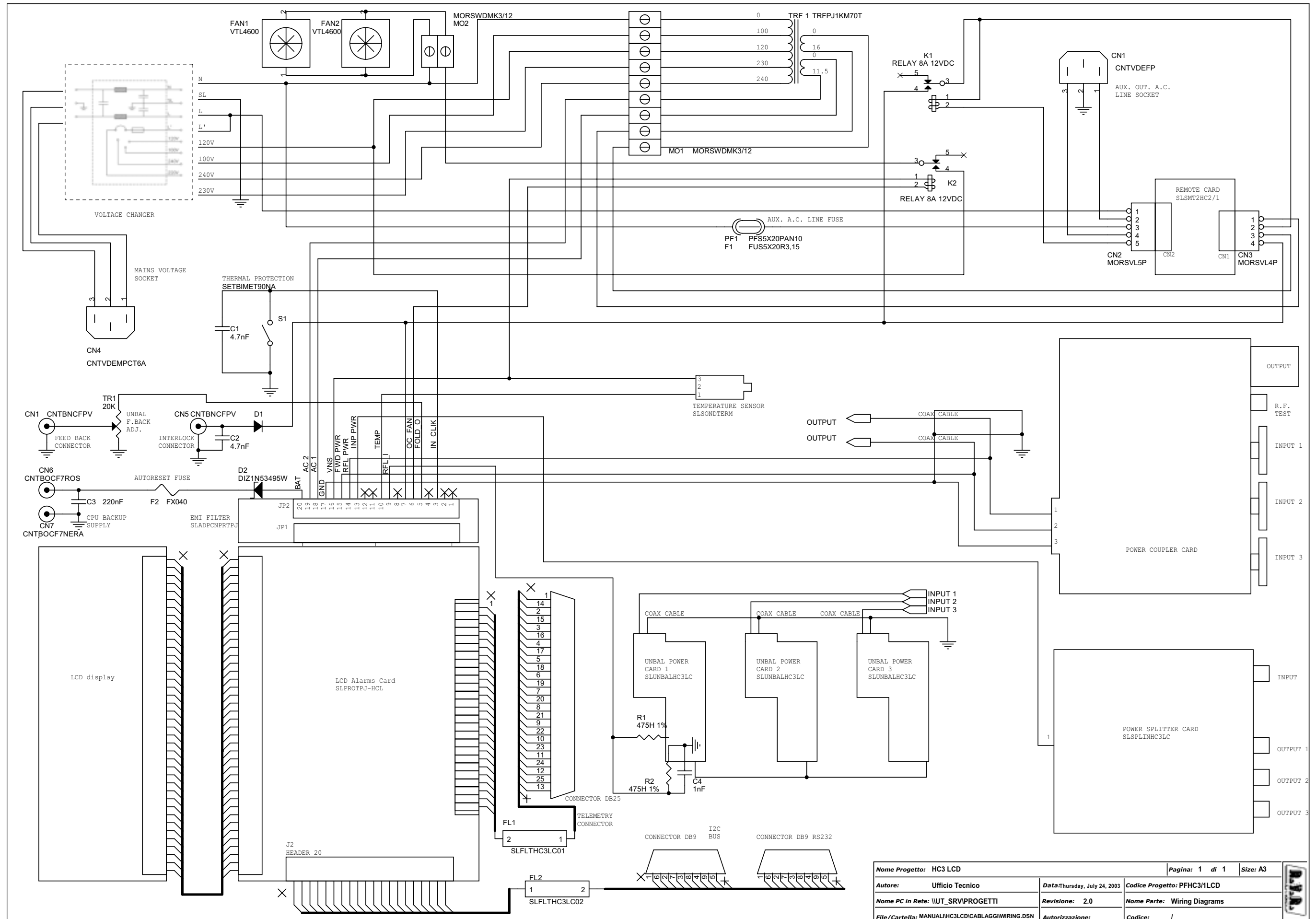

Nome Progetto: HC3 LCD		Pagina: 1 di 1		Size: A3
Autore: Ufficio Tecnico	Data: Thursday, July 24, 2003	Codice Progetto: PFHC3/LCD		
Nome PC in Rete: \\\UT_SRV\PROGETTI	Revisione: 2.0	Nome Parte: Wiring Diagrams		
File/Cartella: MANUALI\HC3LCD\CABLAGGI\WIRING.DSN	Autorizzazione:	Codice: /		

Wiring Diagrams - Bill Of Materials

Item	Quantity	Reference	Part
1	2	CN5, CN1	CNTBNCFPV
2	1	CN1	CNTVDEFP
3	1	CN2	MORSVL5P
4	1	CN3	MORSVL4P
5	1	CN4	CNTVDEMPCT6A
6	1	CN6	CNTBOCF7ROS
7	1	CN7	CNTBOCF7NERA
8	2	C2,C1	4.7nF
9	1	C3	220nF
10	1	C4	1nF
11	1	D1	DIODE
12	1	D2	DIZ1N53495W
13	2	FAN2,FAN1	VTL4600
14	1	FL1	SLFLTHC3LC01
15	1	FL2	SLFLTHC3LC02
16	1	F1	FUS5X20R3,15
17	1	F2	FX040
18	2	K1,K2	RELAY 8A 12VDC
19	2	MO1,MO2	MORSWDMK3/12
20	1	PF1	PFS5X20PAN10
21	2	R1,R2	475H 1%
22	1	S1	SETBIMET90NA
23	1	TRF 1	TRFPJ1KM70T
24	1	TR1	20K

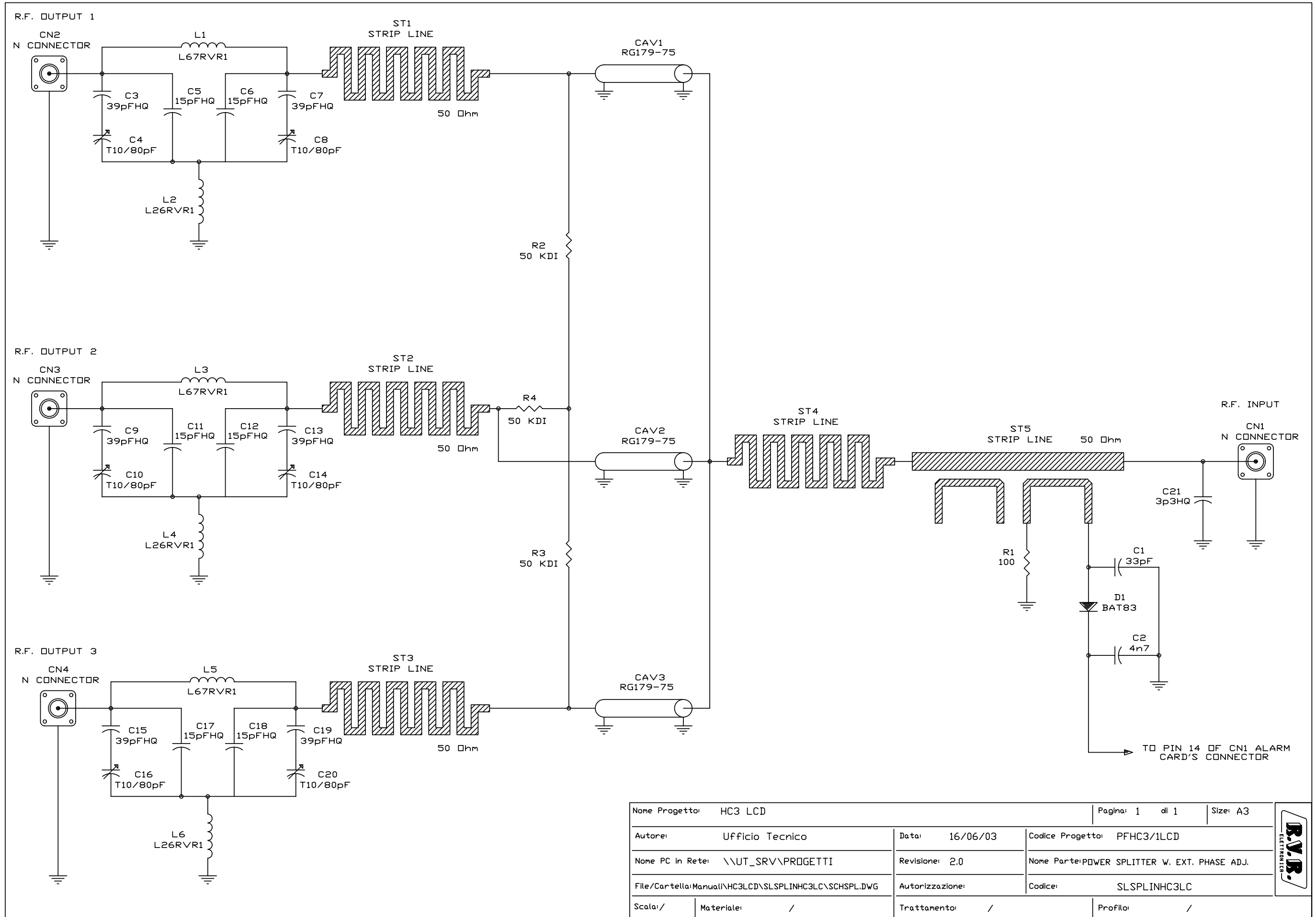

Nome Progetto: HC3 LCD		Pagina: 1 di 1	Size: A3
Autore: Ufficio Tecnico	Data: 16/06/03	Codice Progetto: PFHC3/1LCD	
Nome PC in Rete: \\UT_SRV\PROGETTI	Revisione: 2.0	Nome Parte: POWER SPLITTER W. EXT. PHASE ADJ.	
File/Cartella: Manuali\HC3LCD\SLSPINHC3LC\SCHSPL.DWG	Autorizzazione:	Codice: SLSPLINHC3LC	
Scala: /	Materiale: /	Trattamento: /	Profilo: /



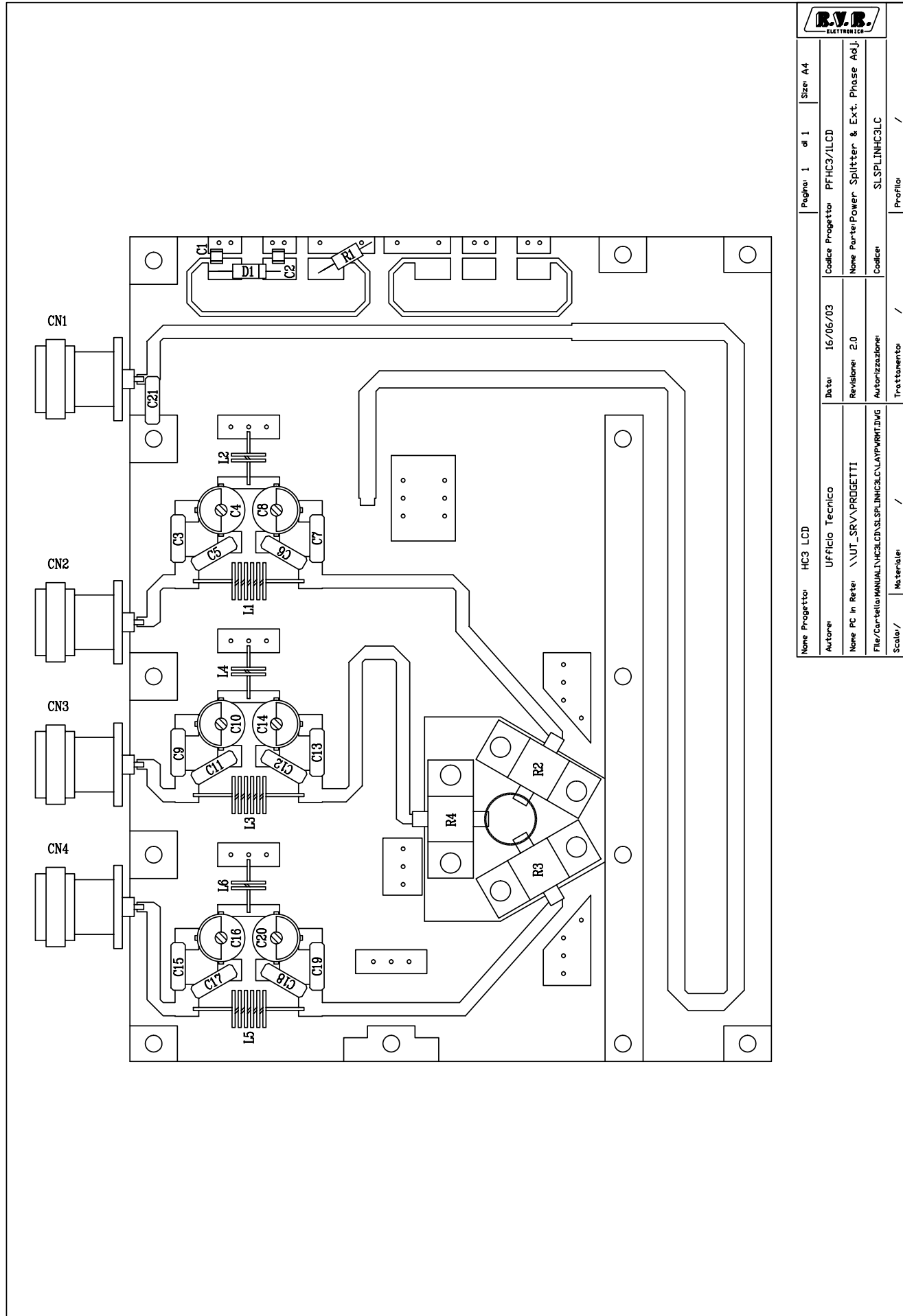

Nome Progetto: HC3 LCD		Pagina: 1 di 1		Size: A4	
Autore: Ufficio Tecnico		Codice Progetto: PFHC3/LCD			
Nome PC in Rete: \\\UT_SRV\PROGETTI		Data: 16/06/03		Nome Parte/Power Splitter & Ext. Phase Adj.	
File/Carrello/MANUALI/HC3LCD/SLSP/INHE3LCD/LAY/PWR/INT.DWG		Revisione: 2.0		Codice: SLSP/INHE3LCD	
Scala: /		Autonizzazione: /		Trattamento: /	
Materiale: /		Profilo: /			

Power Splitter - Bill Of Materials

Item	Q.ty	Reference	Part	Description
1	3	R2,R3,R4	50 KDI	RES. DI TERM. (KDI)
2	1	R1	100	RESISTOR 1/4W 5%
3	1	C21	3p3HQ	CERAMIC CAPACITOR HQ
4	6	C4,C8,C10, C14,C16,C20	T10/80PF	TRIMMER CAPACITOR
5	6	C5,C6,C11, C12,C17,C18	15pFHQ	CERAMIC CAPACITOR HQ
6	6	C3,C7,C9, C13,C15,C19	39pFHQ	CERAMIC CAPACITOR HQ
7	1	C1	33pF	CERAMIC CAPACITOR NP0
8	1	C2	4n7	CERAMIC CAPACITOR
9	3	L2,L4,L6	L26RVR1	2 SP DIA 7 R.A. 1.0mm
10	3	L1,L3,L5	L67RVR1	6 SP DIA 7 R.A. 1.0mm
11	3	CAV1,CAV2, CAV3	RG179-75	CAOX CABLE RG179 75Ohm
12	4	CN1,CN2, CN3,CN4	N CONNECTOR	CONN. N A TELAIO
13	1	D1	BAT83	HOT CARRIER DIODE
14	5	ST1,ST2, ST3,ST4,ST5	STRIP LINE	STRIP LINE

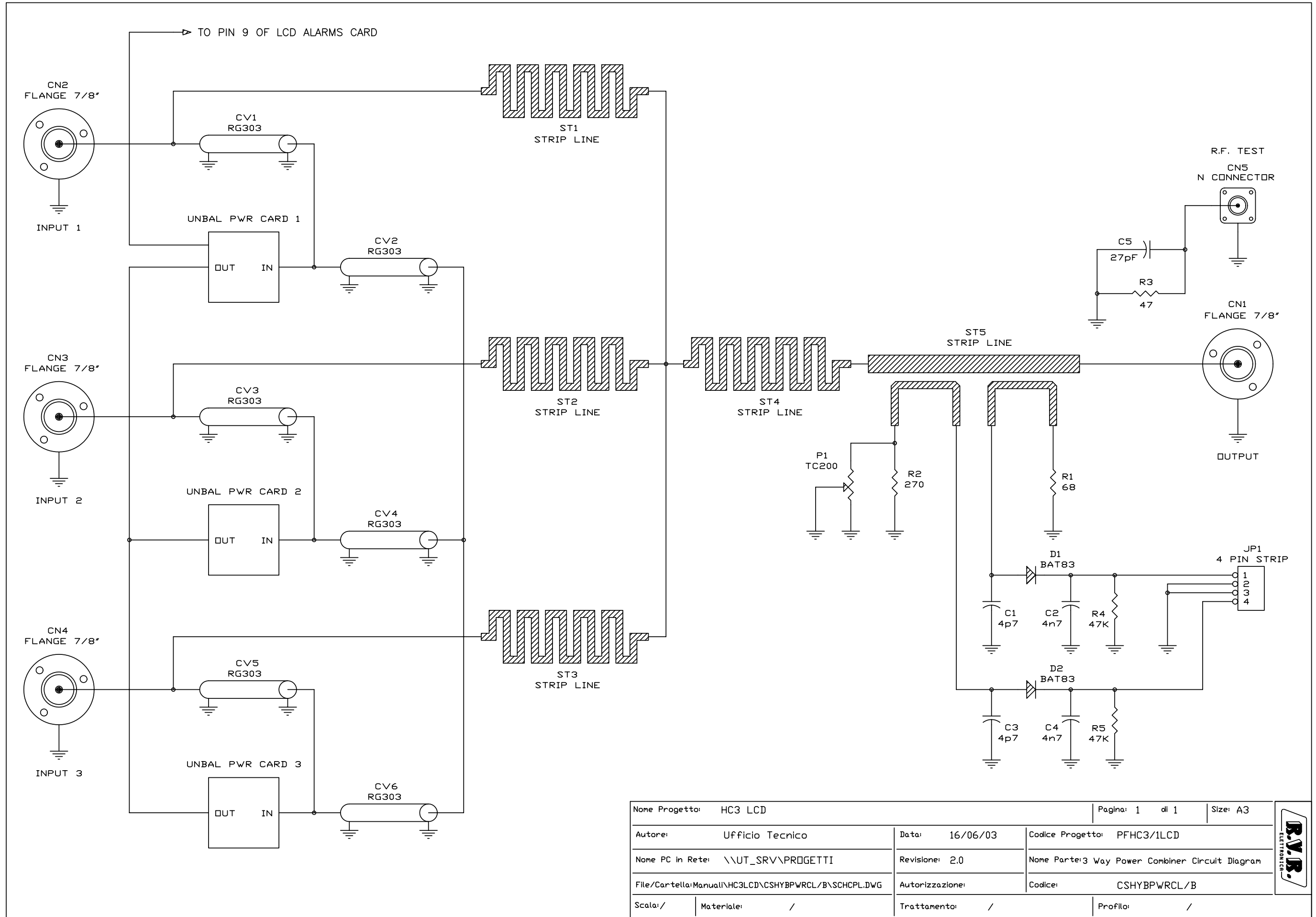

Nome Progetto: HC3 LCD		Pagina: 1 di 1		Size: A3	
Autore: Ufficio Tecnico	Data: 16/06/03	Codice Progetto: PFHC3/1LCD			
Nome PC in Rete: \\UT_SRV\PROGETTI	Revisione: 2.0	Nome Parte: 3 Way Power Combiner Circuit Diagram			
File/Cartella: Manuali\HC3LCD\CSHYBPWRCL\B\SCHCPL.DWG	Autorizzazione:	Codice: CSHYBPWRCL/B			
Scala: /	Materiale: /	Trattamento: /	Profilo: /		



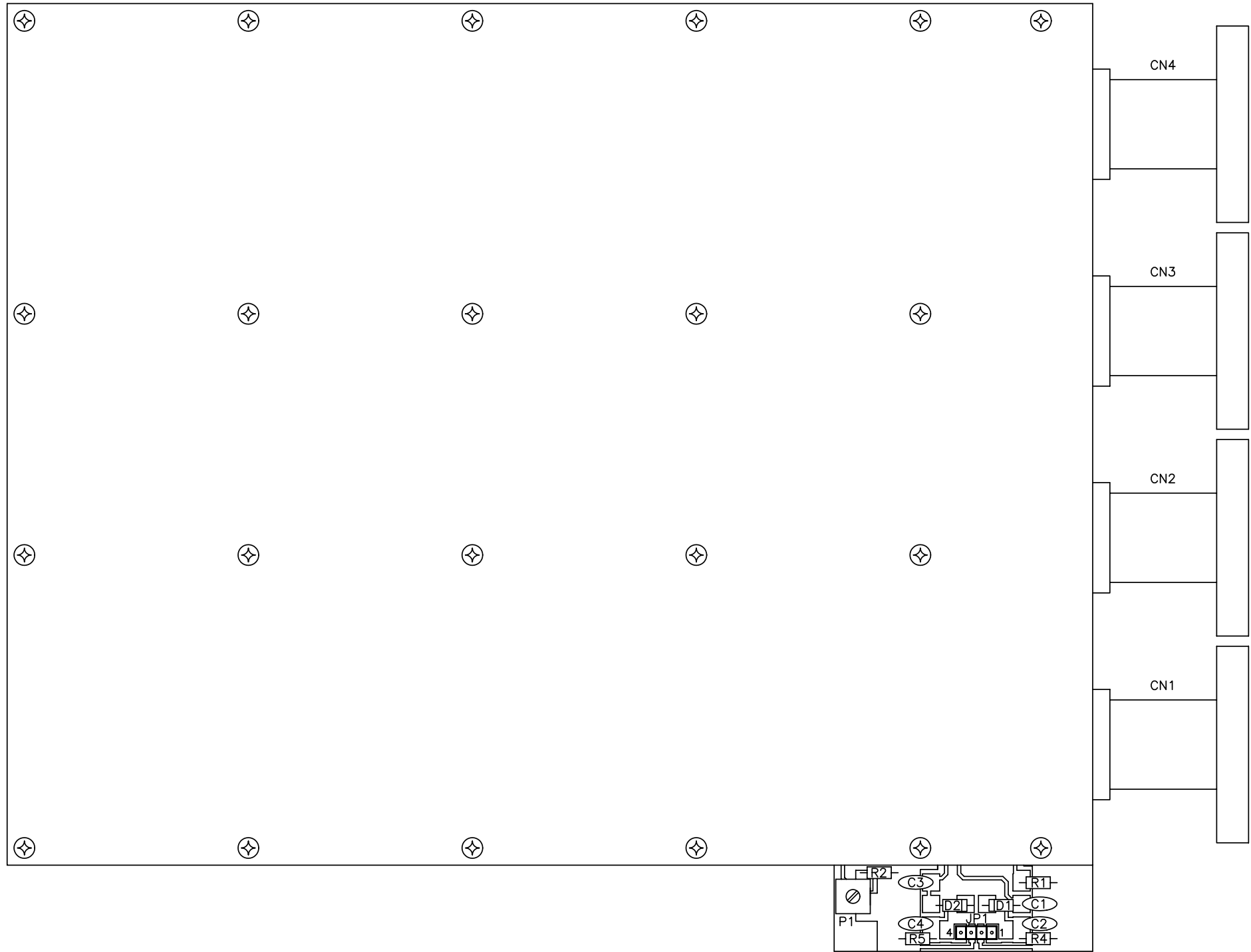

Nome Progetto: HC3 LCD		Pagina: 1 di 1		Size: A3
Autore: Ufficio Tecnico		Data: 16/06/03	Codice Progetto: PFHC3/1LCD	
Nome PC in Rete: \\UT_SRV\PROGETTI		Revisione: 2.0	Nome Parte: POWER COMBINER LAYOUT	
File/Cartella: Manuali\HC3LCD\CSHYBPWRCL\B\LAYCPL.dwg		Autorizzazione:	Codice: CSHYBPWRCL/B	
Scala: 1:1.5	Materiale: /	Trattamento: /	Profilo: /	



Power Coupler - Bill Of Materials

Item	Q.ty	Reference	Part	Description
1	1	R3	47	RESISTOR 1/4W 5%
2	1	R1	68	RESISTOR 1/4W 5%
3	1	R2	270	RESISTOR 1/4W 5%
4	2	R4,R5	47K	RESISTOR 1/4W 5%
5	1	P1	TC200	TRIM. REG. VERT. CERMET
6	1	C5	27pF	CERAMIC CAPACITOR NP0
7	2	C1,C3	4p7	CERAMIC CAPACITOR NP0
8	2	C2,C4	4n7	CERAMIC CAPACITOR
9	1	JP1	4 PIN STRIP	STRIP M P 2.54 4 PIN
10	6	CV1,CV2, CV3,CV4, CV5,CV6	RG303	COAX CABLE RG303
11	1	CN5	N CONNECTOR	CONN. N A TELAIO
12	4	CN1,CN2, CN3,CN4	FLANGE 7/8"	FLANGE 7/8"
13	2	D1,D2	BAT83	HOT CARRIER DIODE
14	5	ST1,ST2, ST3,ST4,ST5	STRIP LINE	STRIP LINE

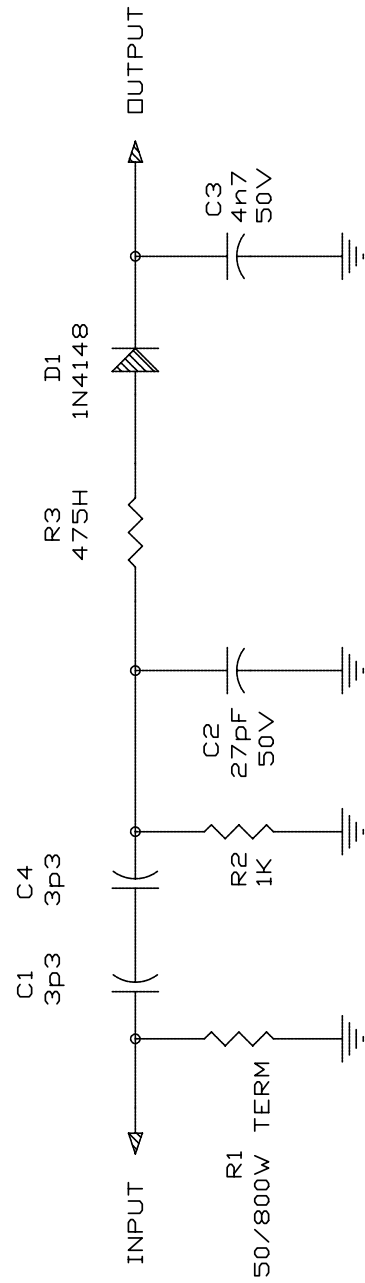

		Pagina: 1	di 1	Size: A4	
Nome Progetto:	HC3 LCD	Data:	16/06/03	Codice Progetto:	PFHC3/LCD
Autore:	Ufficio Tecnico	Revisione:	2.0	Nome Parte:	Unbal Power Card Circuit Diagram
Nome PC in Rete:	\\UT_SRV\PROGETTI	Autore:		Codice:	SLUNBALHC3LC
File/Cartella:	MANUAL\HC3LCD\SLUNBALHC3LC\SLUNBAL.DWG	Trattamento:	/	Profilo:	/
Scala:	/				

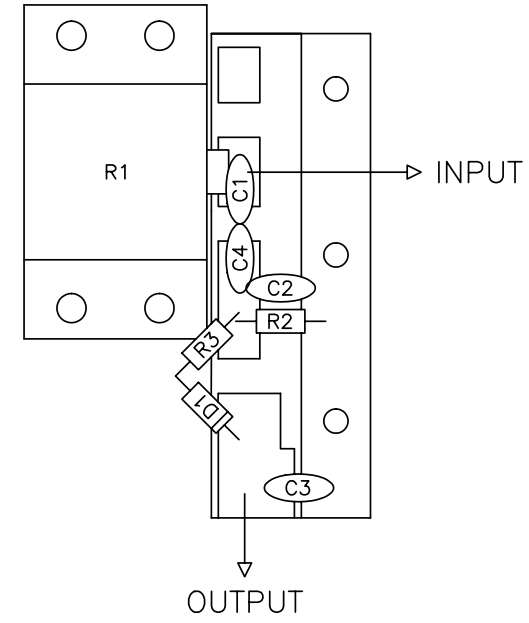

		Pagina: 1	di 1	Size: A4	
Nome Progetto:	HC3 LCD	Data:	16/06/03	Codice Progetto:	PFHC3/LCD
Autore:	Ufficio Tecnico	Revisione:	2.0	Nome Parte:	UNBAL POWER CARD LAYOUT
Nome PC in Rete:	\\UT_SRV\PROGETTI	Autore:		Codice:	SLUNBALHC3LC
File/Cartella:	MANUAL\HC3LCD\SLUNBALHC3LC\LAUNBAL.dwg	Trattamento:	/	Profilo:	/
Scala:	/				

Unbal. Power Card - Bill Of Materials

Item	Q.ty	Reference	Part	Description
1	1	R1	50/800W TER	RES. TERMINAZIONE 800W
2	1	R2	1K	RESISTOR 1/4W 5%
3	2	C1,C4	3p3	CERAMIC CAPACITOR NP0
4	1	C2	27pF	CERAMIC CAPACITOR NP0
5	1	C3	4n7	CERAMIC CAPACITOR
6	1	D1	1N4148	SILICON DIODE
7	1	R3	475H	RESISTOR 1/4W 5%

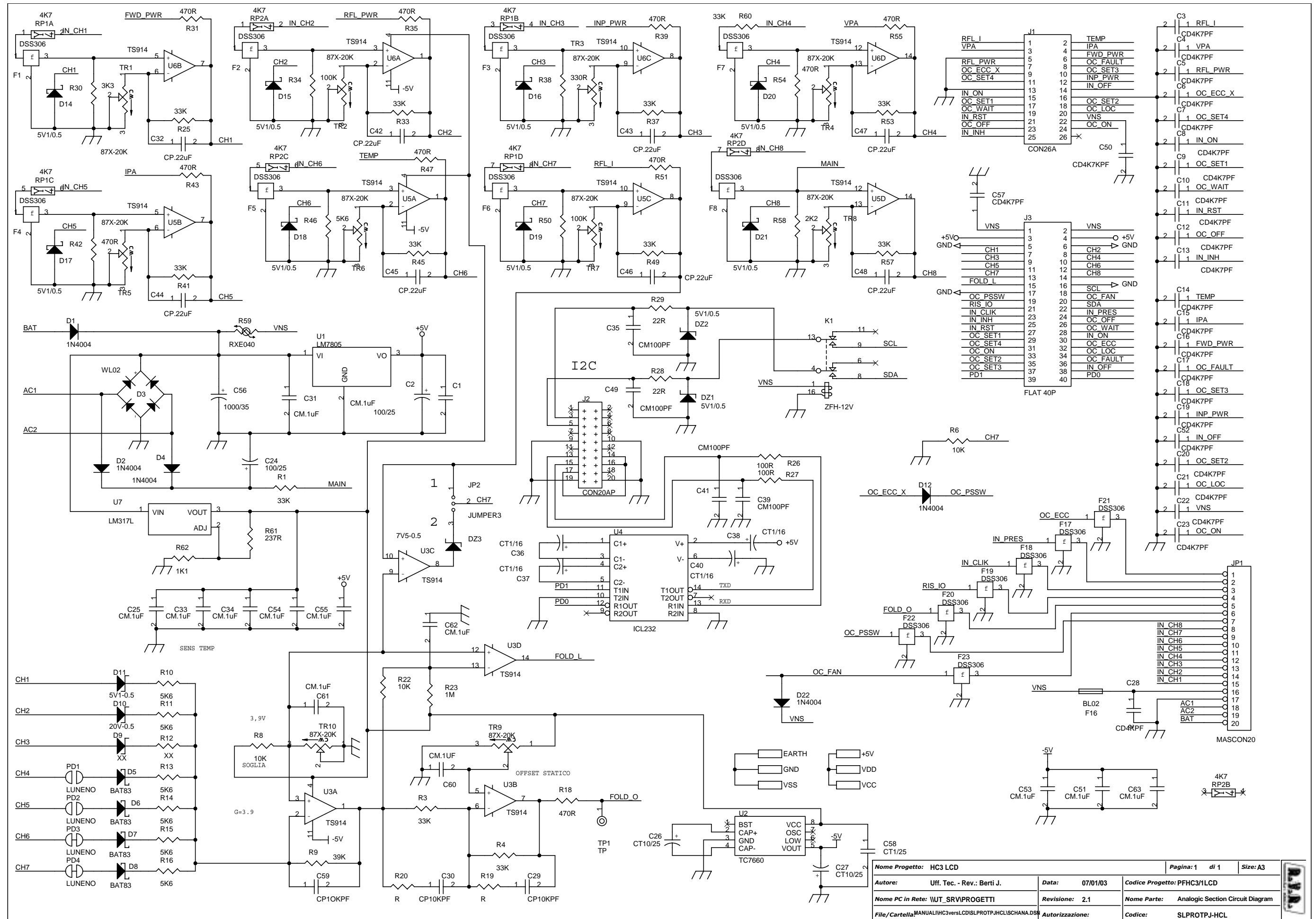

Nome Progetto: HC3 LCD		Pagina: 1 di 1		Size: A3	
Autore: Uff. Tec. - Rev.: Berti J.		Data: 07/01/03		Codice Progetto: PFHC3/LCD	
Nome PC in Rete: \WUT_SRV\PROGETTI		Revisione: 2.1		Nome Parte: Analogic Section Circuit Diagram	
File/Cartella: \MANUAL\HC3\vers\LCD\SLPROTP\JHCLISCHANA.DSN		Autorizzazione:		Codice: SLPROTPJ-HCL	

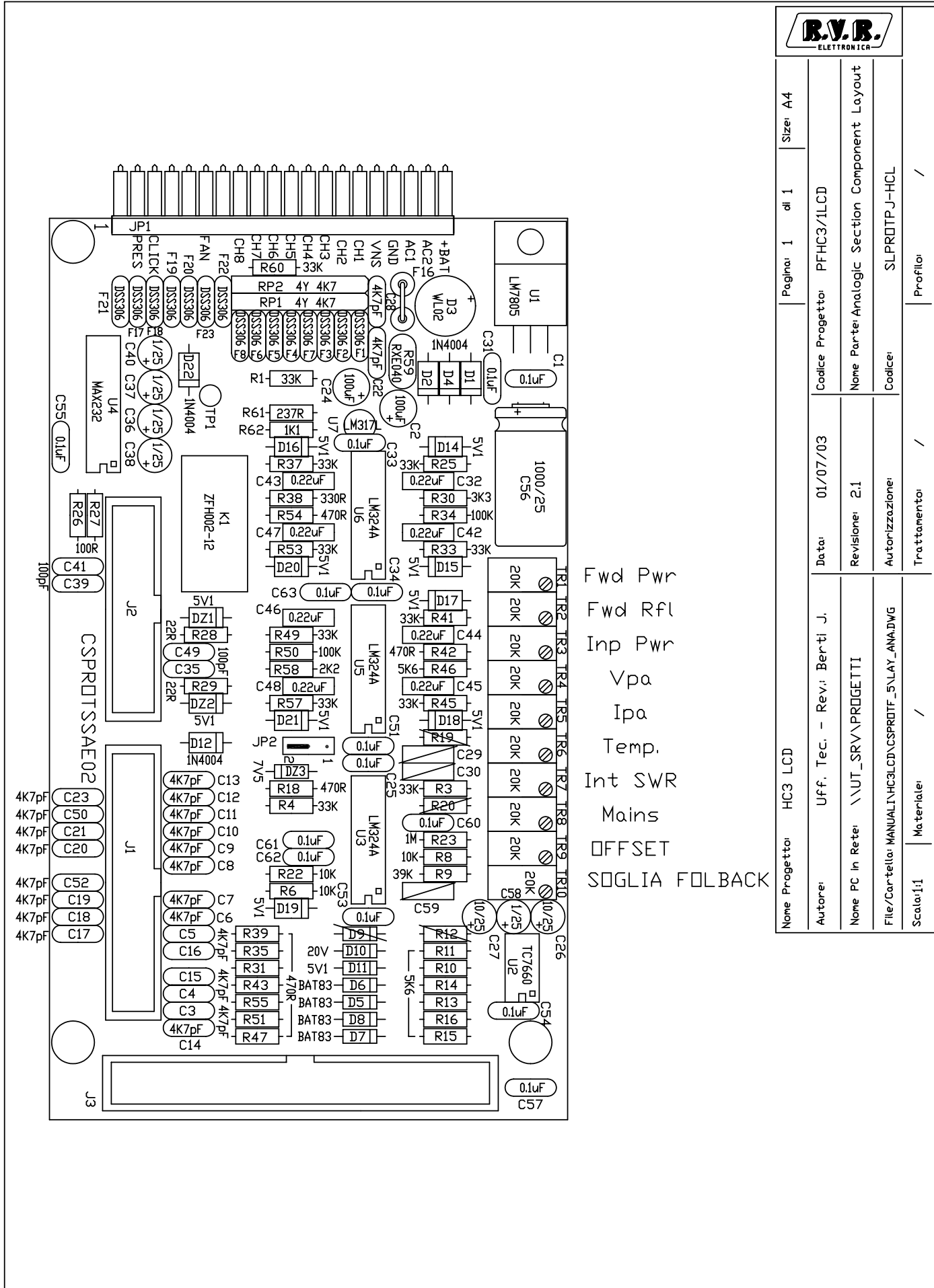

Fwd Pwr
Fwd Rfl
Inp Pwr
Vpa
Ipa
Temp.
Int SWR
Mains
OFFSET
SOGLIA FOLBACK

R.V.R. ELETTRONICA

Nome Progetto: HC3 LCD

Autore: Uff. Tec. - Rev.: Bert J.

Nome PC in Rete: \\UT_SRV\PROGETTI

File/Car-tella: MANUAL\HC3LCD\CSPROT_F_5\LAY_ANA.DWG

Scala: 1:1

Nome Parte: Analogic Section Component Layout

Codice: SLPRTTPJ-HCL

Data: 01/07/03

Revisione: 2.1

Autonizzazione: /

Treatmento: /

Profilo: /

Page: 1 of 1

Size: A4

CPU Analog Section Bill Of Materials
CSPROT F
Version:2,1
07/01/03

Item	Q.ty	Reference	Part
1	13	C1,C25,C31, C33,C34,C51, C53,C54,C55, C60,C61,C62,C63	CM.1UF
2	2	C2,C24	100/25
3	22	C3,C4,C5,C6, C7,C8,C10, C11,C12,C13, C14,C15,C16, C17,C18,C19, C20,C21,C22, C23,C52,C57	CD4K7PF
4	2	C26,C27	CT10/25
5	1	C28	CD4KPF
6	2	C29,C30	CP10KPF
7	8	C32,C42,C43, C44,C45,C46, C47,C48	CP.22UF
8	4	C35,C39,C41, C49	CM100PF
9	4	C36,C37,C38, C40	CT1/16
10	1	C50	CD4K7KPF
11	1	C56	1000/35
12	1	C58	CT1/25
13	1	C59	CP10KPF
14	2	DZ1,DZ2	5V6/1
15	1	DZ3	6V8-0.5
16	4	D1,D2,D4,D22	1N4004
17	1	D3	WL02
18	4	D5,D6,D7,D8	BAT83
19	3	D9,D10,D11	20V-0.5
20	8	D14,D15,D16, D17,D18,D19, D20,D21	5V1/0.5
21	15	F1,F2,F3,F4, F5,F6,F7,F8, F17,F18,F19, F20,F21,F22, F23	DSS306
22	1	F16	BL02
23	1	JP1	MASCON20
24	1	JP2	JUMPER3
25	1	J1	CON26A
26	1	J2	CON20AP
27	1	J3	FLAT 40P
28	1	K1	ZFH-12V
29	4	PD1,PD2,PD3, PD4	LUNENO

30	2	RP1,RP2	4K7
31	12	R1,R3,R4,R25, 33K R33,R37,R41, R45,R49,R53, R57,R60	
32	3	R6,R8,R22	10K
33	1	R9	22K
34	6	R10,R11, R13,R14,R15, R16	5K6
35	9	R18,R31,R35, R39,R42,R43, R47,R51,R55	470R
36	2	R19,R20	R
37	1	R23	1M
38	2	R26,R27	100R
39	2	R28,R29	22R
40	1	R30	3K3
41	2	R34,R50	100K
42	2	R38,R54	330R
43	2	R46,R58	2K2
44	1	R59	RXE020
45	1	R61	237R
46	1	R62	1K1
47	1	TP1	TP
48	10	TR1,TR2,TR3, TR4,TR5,TR6, TR7,TR8,TR9, TR10	87X-20K
49	1	U1	LM7805
50	1	U2	TC7660
51	3	U3,U5,U6	TS914
52	1	U4	ICL232
53	1	U7	LM317L
54	2	R12,D9	N.C.
55	1	D23	1N4007

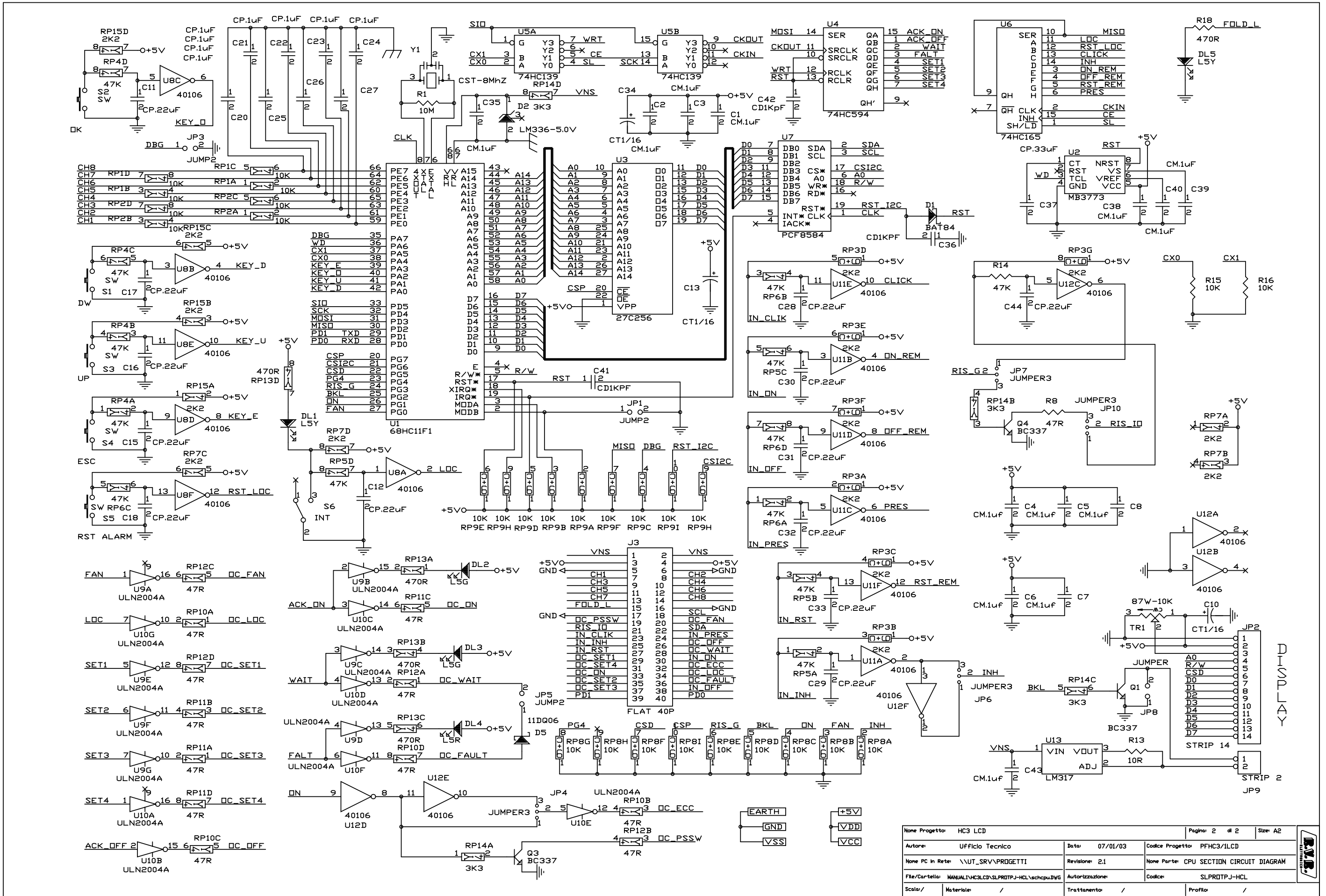

None Progettor: HC3 LCD		Pagina 2 di 2		Size A2	
Autore: Ufficio Tecnico		Data: 07/01/03		Codice Progettor: PFHC3/LCD	
None PC In Rete: \\UT_SRV\PROGETTI		Revisione: 2.1		None Parte: CPU SECTION CIRCUIT DIAGRAM	
File/Cartella: MANUAL\HC3LCD\SLPROTPJ-HCL\schcpu.DWG		Autorizzazione:		Codice: SLPROTPJ-HCL	
Scala:	Material:	Trattamentor:	Profilor:		

Scheda CPU Bill Of Materials
 CSPROT F
 Version:2,1
 07/01/03

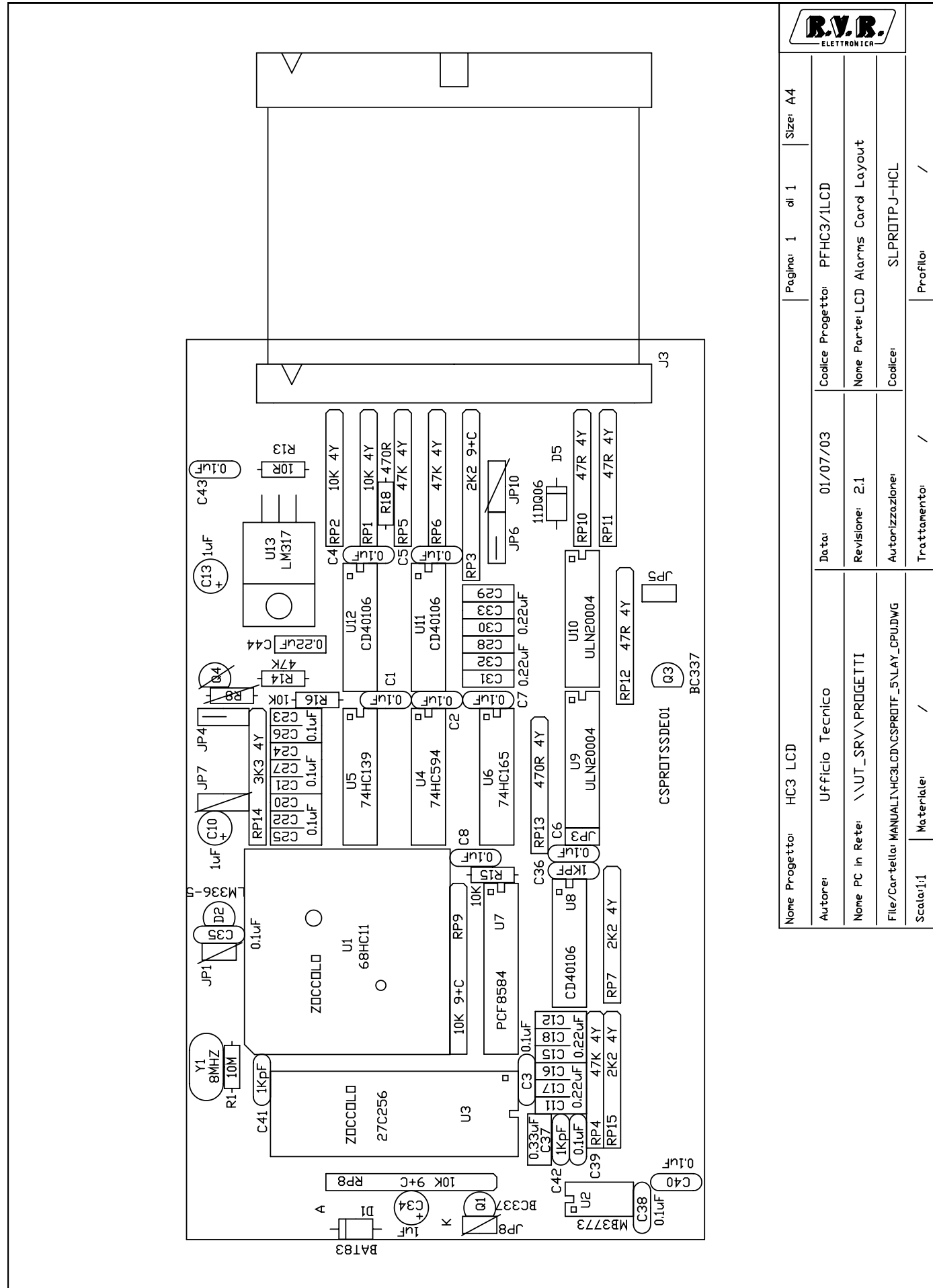

None Progetto: HC3 LCD		Pagina: 1 di 1		Size: A4	
Autore: Ufficio Tecnico		Codice Progetto: PFHC3/LCD			
Nome PC in Rete: \\UT_SRV\PROGETTI		Nome Parte: LCD Alarms Card Layout			
File/Cartella: MANUAL\HC3LCD\CSPROT F_5\LAY_CPU.DWG		Codice: SLPR0TPJ-HCL			
Scala:1:1		Trattamento: /		Profilo: /	

Item	Q.ty	Reference	Part
1	13	C1,C2,C3, C4,C5,C6, C7,C8,C35, C38,C39,C40,C43	CM.1UF
2	3	C10,C13,C34	CT1/16
3	13	C11,C12,C15, C16,C17,C18, C28,C29,C30, C31,C32,C33,C44	CP.22UF
4	8	C20,C21,C22, C23,C24,C25, C26,C27	CP.1UF
5	3	C36,C41,C42	CD1KPF
6	1	C37	CP.33UF
7	2	DL1,DL5	L5Y
8	2	DL2,DL3	L5G
9	1	DL4	L5R
10	1	D1	BAT84
11	1	D2	LM336-5.0V
12	1	D5	11DQ06
13	3	JP1,JP3,JP5	JUMP2
14	1	JP2	STRIP 14
15	4	JP4,JP6,JP7, JP10	JUMPER3
16	1	JP8	JUMPER
17	1	JP9	STRIP 2
18	1	J3	FLAT 40P
19	3	Q1,Q3,Q4	BC337
20	6	RP1,RP2,RP8, 10K RP9,R15,R16	
21	3	RP3,RP7,RP15 2K2	
22	4	RP4,RP5,RP6, R14	47K
23	4	R8,RP10,RP11, 47R RP12	
24	2	RP13,R18	470R
25	1	RP14	3K3
26	1	R1	10M
27	1	R13	10R
28	5	S1,S2,S3,S4, S5	SW
29	1	S6	INT
30	1	TR1	87W-10K
31	1	U1	68HC11F1
32	1	U2	MB3773
33	1	U3	27C256
34	1	U4	74HC594
35	1	U5	74HC139
36	1	U6	74HC165
37	1	U7	PCF8584
38	3	U8,U11,U12	40106
39	2	U9,U10	ULN2004A
40	1	U13	LM317
41	1	Y1	CST-8MHZ

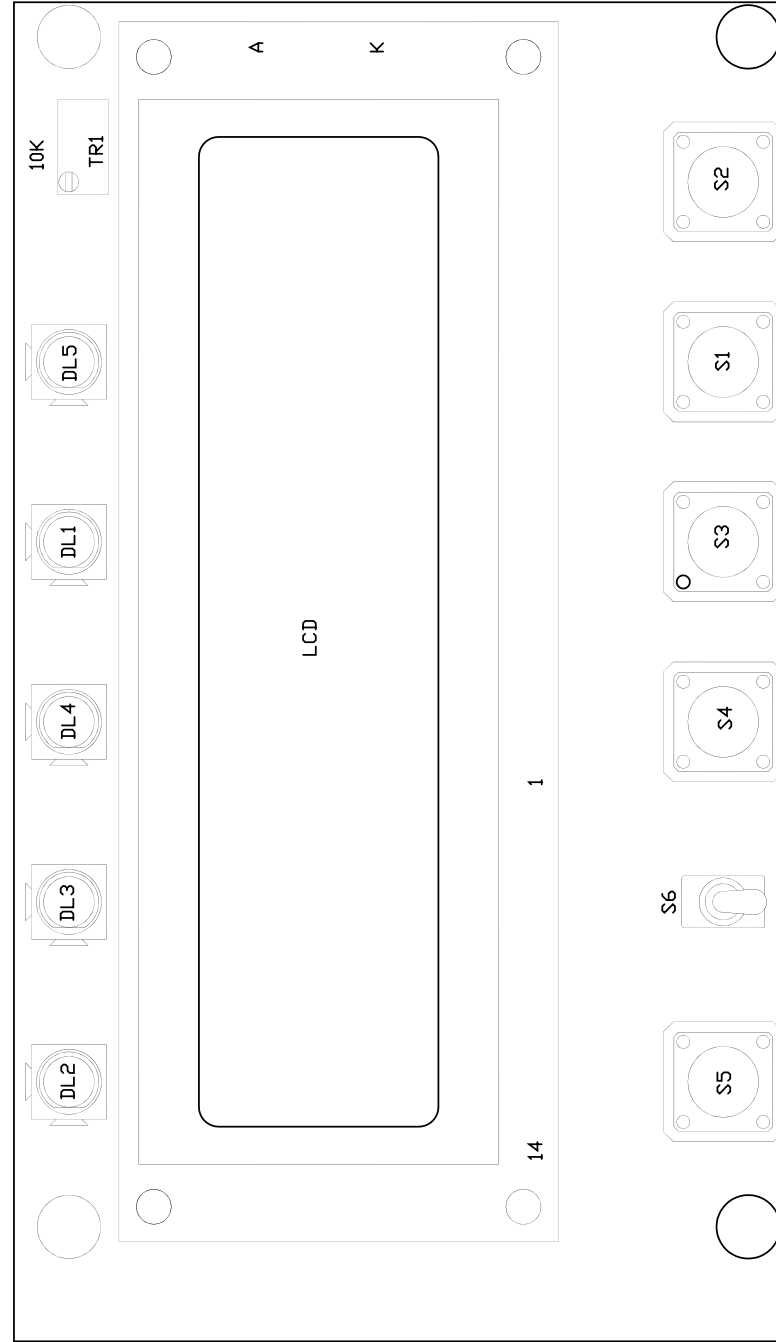

		Pagina: 1	di 1	Size: A4	
Nome Progetto:	HC3 LCD	Data:	01/07/03	Codice Progetto:	PFHC3/ILCD
Autore:	Ufficio Tecnico	Revisione:	2.1	Nome Parte: CPU Display Section Component Layout	
Nome PC in Rete:	\\UT_SRV\PROGETTI	Autorizzazione:		Codice:	
File/Cartella:	MANUALI\HC3LCD\CSPROTIF_5\LAY_DSP.JPG	Trattamento:	/	SLPRTPJ-HCL	
Scala: 1:1	Materiale:	/		Profilo:	
		/			

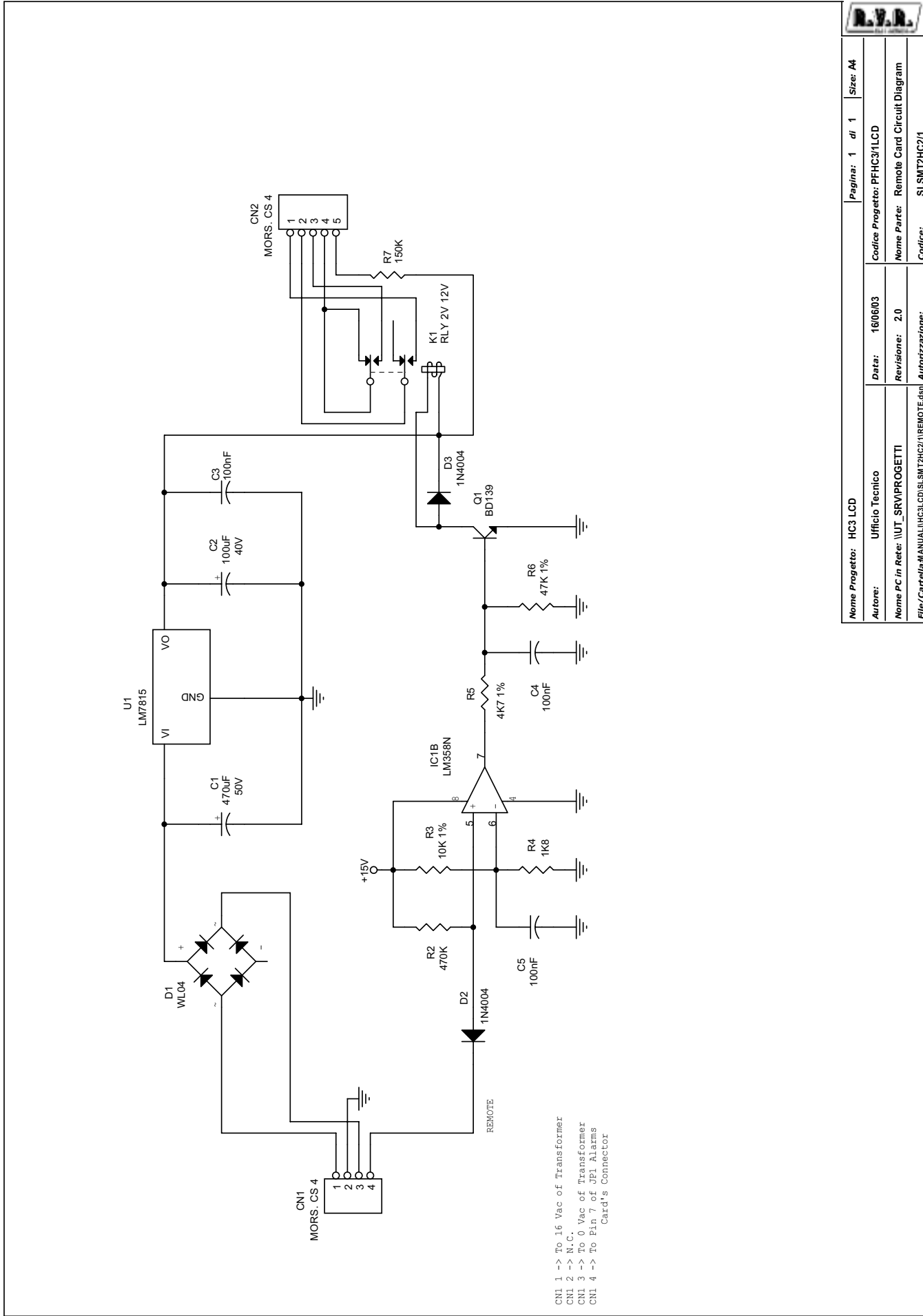

Nome Progetto: HC3 LCD		Pagina: 1 di 1		Size: A4
Autore: Ufficio Tecnico	Data: 16/06/03	Codice Progetto: PFHC3/LCD		
Nome PC in Rete: \\\UT_SRV\PROGETTI	Revisione: 2.0	Nome Parte: Remote Card Circuit Diagram		
File/Carrella: \MANUAL\HC3LCD\SMT2HC2\1REMOTE.dsn	Autore/Revisione:	Codice: SLSMT2HC2/1		

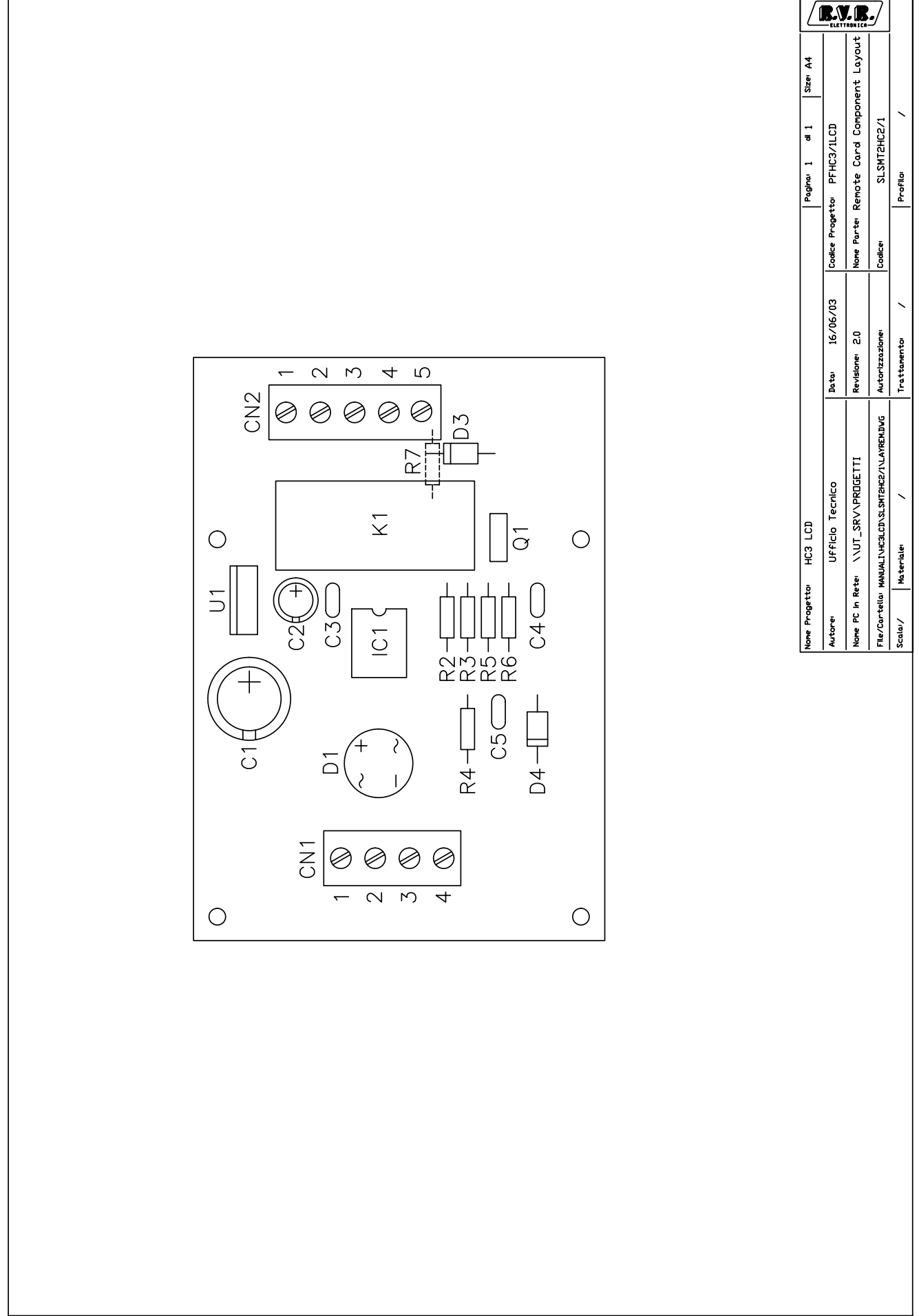

Nome Progetto: HC3 LCD		Pagina: 1 di 1		Size: A4
Autore: Ufficio Tecnico	Data: 16/06/03	Codice Progetto: PFHC3/LCD		
Nome PC in Rete: \\\UT_SRV\PROGETTI	Revisione: 2.0	Nome Parte: Remote Card Component Layout		
File/Carrella: \MANUAL\HC3LCD\SMT2HC2\1LAYRELVG	Autore/Revisione:	Codice: SLSMT2HC2/1		
Scala: /	Materiale: /	Trattamento: /	Profilo: /	

Remote Card - Bill Of Materials

Item	Quantity	Reference	Part	DESCRIPTION
1	1	R4	1K8	RESISTOR 1/4W 5%
2	1	R5	4K7 1%	RESISTOR 1/4W 1%
3	1	R3	10K 1%	RESISTOR 1/4W 1%
4	1	R6	47K 1%	RESISTOR 1/4W 1%
5	1	R2	470K	RESISTOR 1/4W 5%
6	1	R7	150K	RESISTOR 1/4W 5%
7	3	C3,C4,C5	100NF	CERAMIC CAPACITOR
8	1	C2	100UF	ELECTROLYTIC CAPACITOR
9	1	C1	470UF	ELECTROLYTIC CAPACITOR
10	2	CN1,CN2	MORS. CS 4	MORS. C.S. 4 CONT.
11	1	K1	RLY 2V 12V	RELAY 2 VIE 12V
12	2	D2,D3	1N4004	SILICON DIODE 400V
13	1	D1	WL04	DIODE BRIDGE 1.5A
14	1	U1	LM7815	POS. STABILIZER
15	1	Q1	BD139	NPN TRANSISTOR
16	1	IC1	LM358N	DOUBLE OP. AMP.

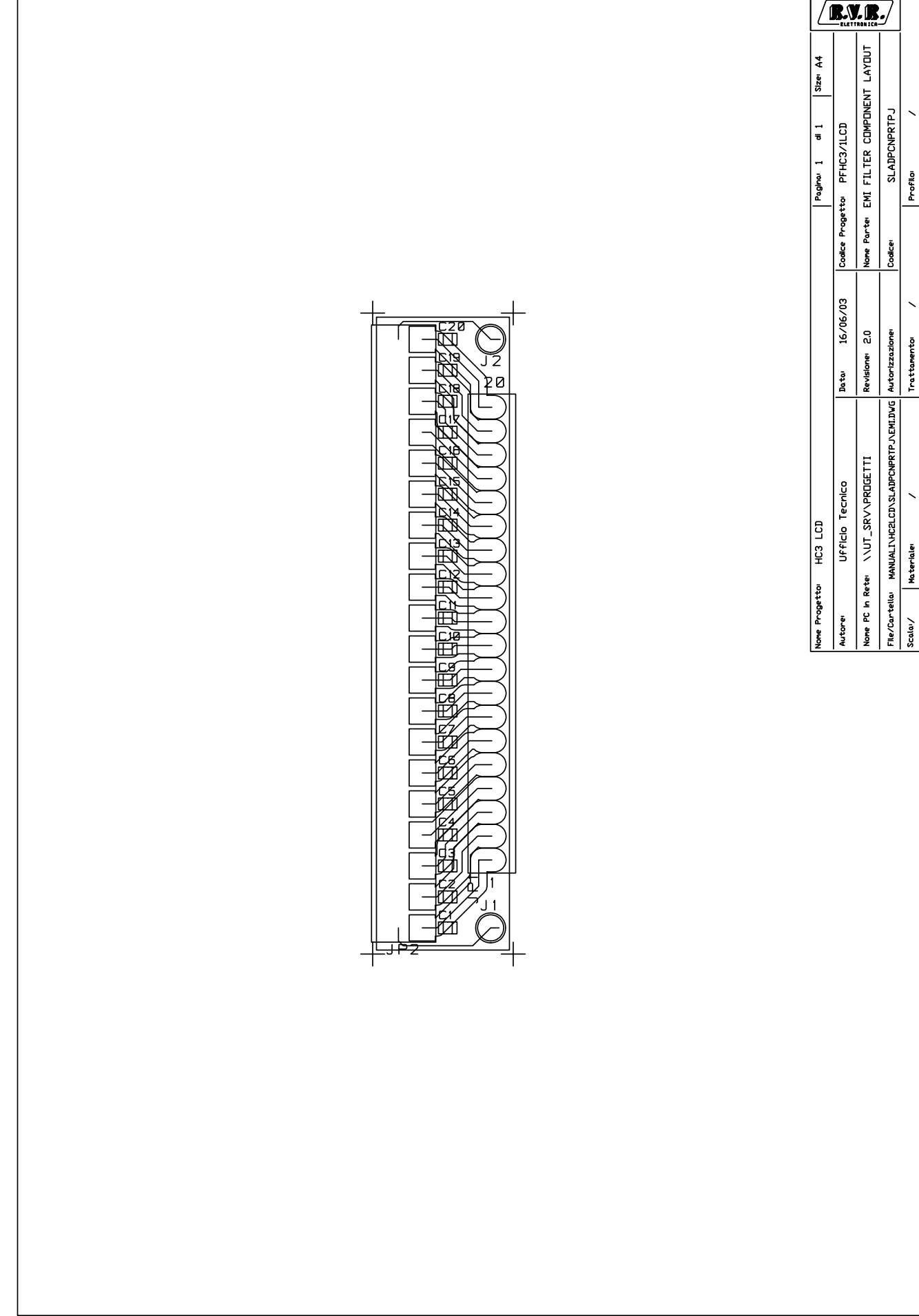
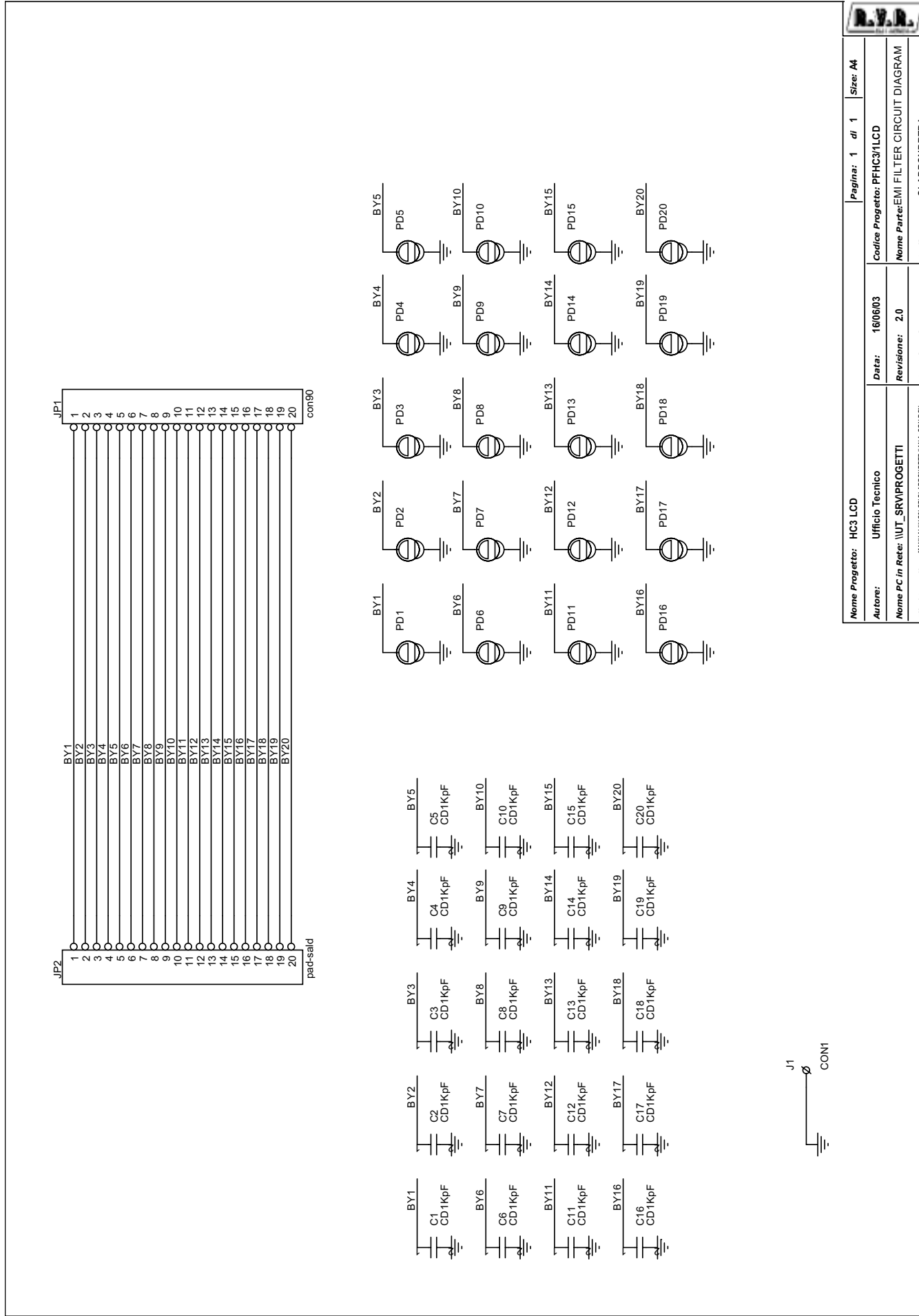

EMI Filter - Bill Of Materials

Item	Quantity	Reference	Part
1	20	C1,C2,C3,C4,C5,C6,C7,C8, C9,C10,C11,C12,C13,C14, C15,C16,C17,C18,C19,C20	CD1KpF
2	1	JP1	con90
3	1	JP2	pad-sald
4	1	J1	CON1
5	20	PD1,PD2,PD3,PD4,PD5,PD6, PD7,PD8,PD9,PD10,PD11, PD12,PD13,PD14,PD15,PD16, PD17,PD18,PD19,PD20	

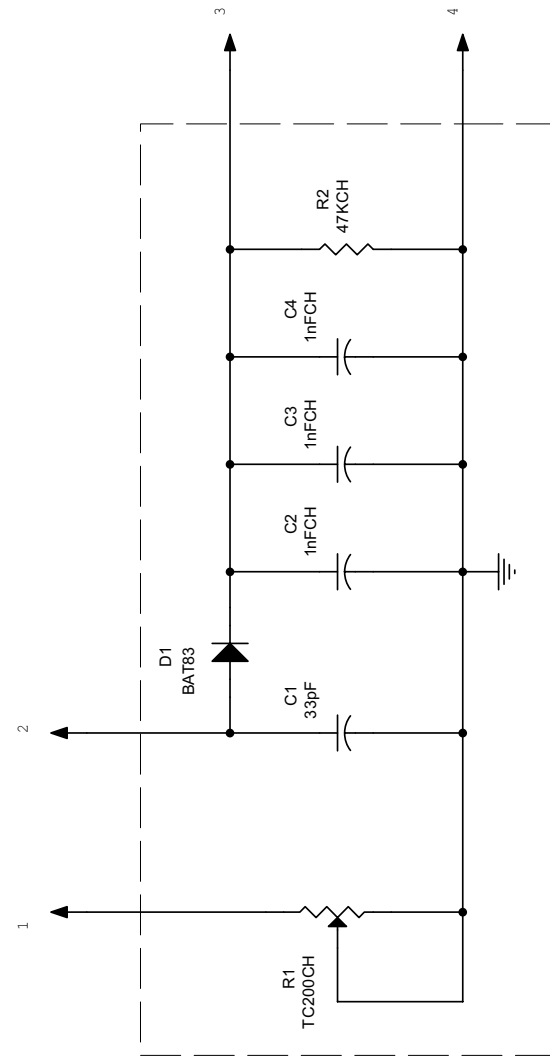

Nome Progetto: HC3 LCD		Pagina: 1 di 1		Size: A4
Autore: Ufficio Tecnico		Data: 16/06/03		Codice Progetto: PFHC3/LCD
Nome PC in Rete: \LUT_SRV\PROGETTI		Revisione: 2.0		Nome Parte: POWER METER CARD
File/Cartella: MANUAL\HC3LCD\SLPWRMTRHCS\PWR_MTR.DSN		Autorizzazione:		Codice: SLPWRMTRHCS

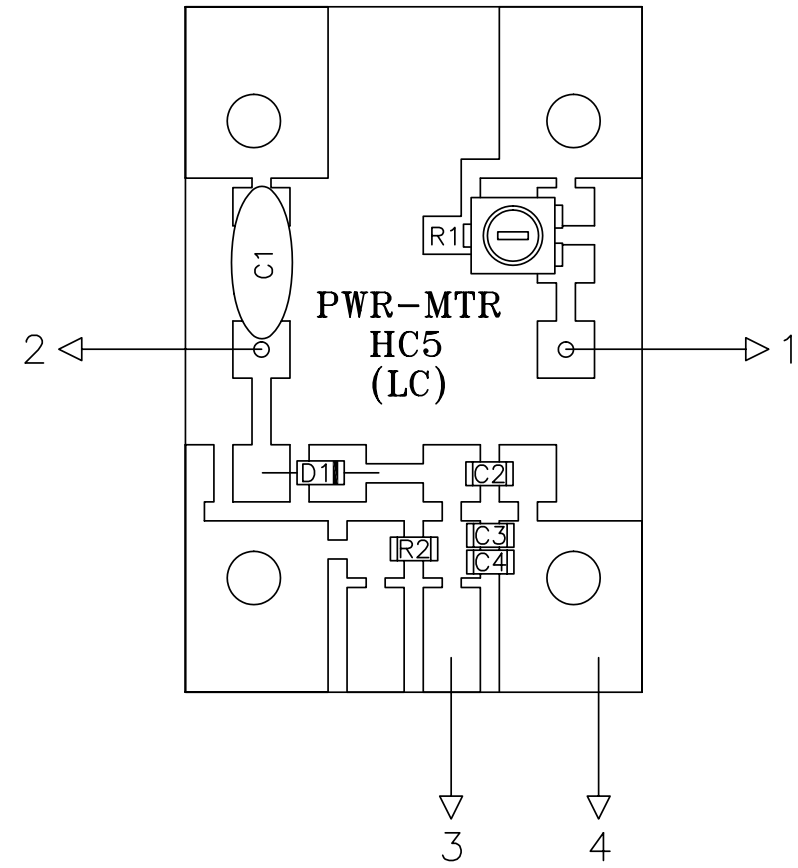

Nome Progetto: HC3 LCD		Pagina: 1 di 1		Size: A4
Autore: Ufficio Tecnico		Data: 16/06/03		Codice Progetto: PFHC3/LCD
Nome PC in Rete: \LUT_SRV\PROGETTI		Revisione: 2.0		Nome Parte: POWER METER CARD LAYOUT
File/Car-tella: MANUAL\HC3LCD\SLPWRMTRHCS\LAYOUT.DWG		Autorizzazione:		Codice: SLPWRMTRHCS
Scala:	Metri:	/	Trattamento:	/
			Profilo:	/

POWER METER CARD - Bill Of Materials

Item	Q.ty	Reference	Part	DESCRIPTION
1	1	R2	47KCH	CHIP RESISTOR
2	1	R1	TC200CH	TRIM. REG. VERT. CERMET SMD
3	1	C1	33PF	CERAMIC CAPACITOR NP0
4	3	C2,C3,C4	1NFCH	CERAMIC CHIP CAPACITOR
5	1	D1	BAT83	HOT CARRIER DIODE

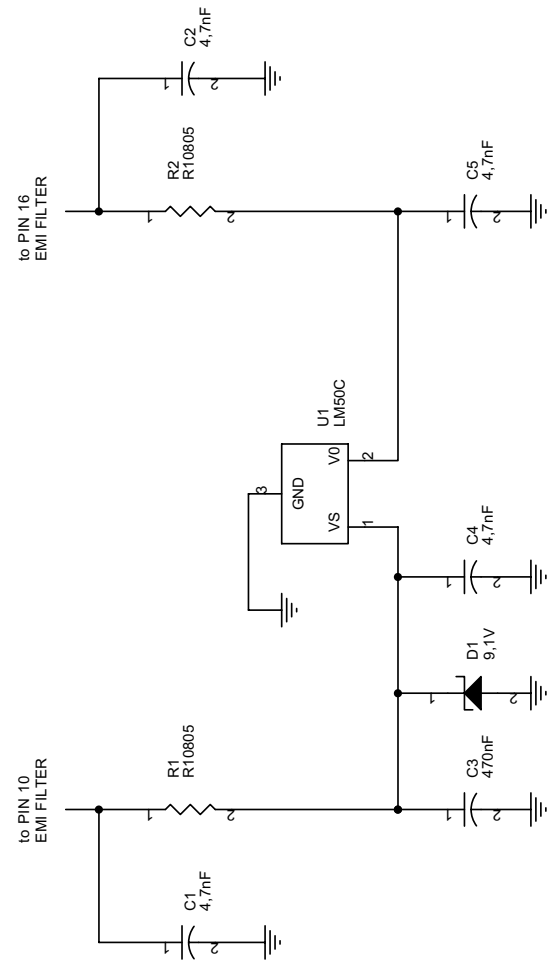

Nome Progetto: HC3 LCD		Pagina: 1	di 1	Size: A4
Autore: Ufficio Tecnico		Data: 16/06/03	Codice Progetto: PFHC3/LCD	
Nome PC in Rete: \\\UT_SRV\PROGETTI		Revisione: 2.0	Nome Parte: Sonda Termica	
File/Carrello\MANUALI\HC3LCD\SLSONDTERM\SONDTERM.dwg		AutORIZZAZIONE:		
		Codice: SLSONDTERM		

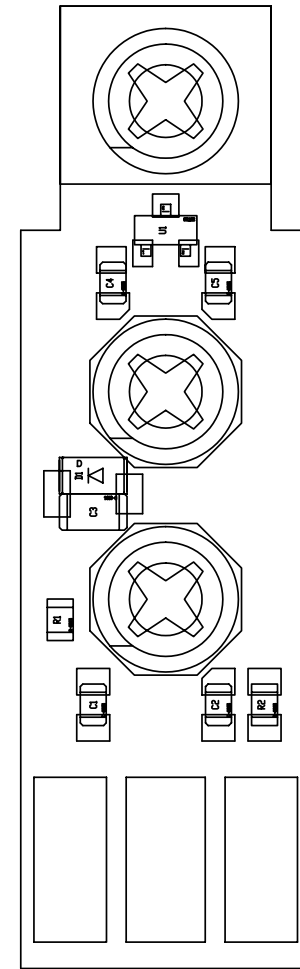

Nome Progetto: HC3 LCD		Pagina: 1	di 1	Size: A4
Autore: Ufficio Tecnico		Data: 16/06/03	Codice Progetto: PFHC3/LCD	
Nome PC in Rete: \\\UT_SRV\PROGETTI		Revisione: 2.0	Nome Parte: SONDA TERMICA	
File/Carrello\MANUALI\HC3LCD\SLSONDTERM\CSSTERM.DWG		AutORIZZAZIONE:		
Scala: 3:1		Trattamento: /		
Materiale: /		Profilo: /		

Sonda Termica
 SLSONDTERM
 Revision: 2.0
 Ufficio Tecnico
 17/06/03

Item	Quantity	Reference	Part	Description
1	4	C1,C2,C4,C5	4,7nF	Cond. SMD 0805
2	1	C3	470nF	Cond. SMD 1206
3	1	D1	9,1V	MINIMELF SMD Zener Diode
4	2	R1,R2	R10805	Res. SMD 0805
5	1	U1	LM50C	Temperature sensor